



# Design, Installation & Testing Instruction

## R410A Heat Recovery 60Hz



**REYQ96MTJU**

## **Preface**

This system is a modular zone controllable air conditioning system of great sophistication which is capable of assembly in a variety of different configurations. It would, however, be no exaggeration to say that the full potential of the systems functions can only be achieved in combination with the skills of those involved in the design of the equipment itself and those responsible for the installation work.

As the move towards intelligent buildings has gathered momentum, so we have also been seeing ever more a growing demand for a wider range of independently controllable building related functions.

Against this background there have also quite naturally been calls for the development of more distributed types of air conditioning systems while at the same time taking full account of the need to use energy economically by demand matching in view of the huge annual increases in the demand for electric power seen in recent years.

We have therefore prepared this installation manual to enable installation work to be handled confidently on the basis of a clear understanding of the special features of this system. We have paid particular attention to points of difference in installation procedure between this system and the more traditional package and room air conditioning system.

The manual is designed specifically to cater for those supervising installation work and concentrates on those products which are currently on the market. Essential points which need to be taken into consideration when designing an appropriate configuration for the system and in each of the separate installation processes have also been included.

We have also added a section covering problems which have arisen in connection with installation work undertaken to date in an attempt to prevent the recurrence of the same problems.

Please be sure to read this manual thoroughly before starting installation work in order to ensure that all such work is carried out with maximum efficiency and to maximum effect.

The following technical documents are also available from Daikin. Please use these documents together with this manual to conduct efficient servicing.

Service Manual VRV R410A Heat Recovery 60Hz Series Si39-405 Sept., 2004.

Oct., 2004

After Sales Service Division

# VRV<sup>®</sup> System R410A PLUS Series

<b>Part 1</b>	<b>General Information .....</b>	<b>1</b>
1.	Product Outline .....	2
1.1	Model Names of Indoor/Outdoor Units .....	2
1.2	External Appearance .....	3
1.3	Model Selection .....	4
2.	Points to Bear in Mind at the System Design .....	5
2.1	Points Relating to the Performance of the Air Conditioning Units .....	5
2.2	The Installation is of Vital Importance .....	7
2.3	Striking a Balance between System Installation and General Construction Work (Comprehensive Flow Chart) .....	8
2.4	Points to Bear in Mind when Preparing the Contract Drawings .....	9
3.	Installation .....	13
3.1	Step by Step Installation Procedure .....	13
3.2	Work Involved in Individual Operations and Points to be Borne in Mind ....	14
4.	Test Operation .....	63
4.1	Procedure and Outline .....	63
4.2	Operation When Power is Turned On .....	66
4.3	Outdoor Unit PC Board Layout .....	67
4.4	Field Setting .....	68
5.	Caution for Refrigerant Leaks .....	96
5.1	Caution for Refrigerant Leaks .....	96
6.	Hand Over to Customer .....	98
6.1	Operational Steps .....	98
7.	Appendix .....	99
7.1	Operating Noise of Indoor Units .....	99
7.2	Allowable Piping Length .....	101
7.3	Refrigerant branch kit selection .....	104
7.4	Pipe size selection .....	106
7.5	How to calculate the additional refrigerant to be charged .....	107
7.6	REFNET Pipe Connections for VRV R410A Series .....	109
7.7	VRV Inspection Sheet .....	114
7.8	Piping System Diagrams .....	118
7.9	Wiring Diagrams .....	121
7.10	Bad Examples and Good Examples in Installation .....	123
<b>Part 2</b>	<b>Installation Manual REYQ96MTJU .....</b>	<b>131</b>
1.	Introduction .....	136
1.1	Combination .....	136
1.2	Standard Operation Limit .....	136
1.3	Standard Supplied Accessories .....	137
1.4	Option Accessory .....	138

1.5	Technical Specifications (1)	138
1.6	Electrical Specifications (1)	139
2.	Main Components	140
3.	Selection of Location	141
4.	Inspecting and Handling the Unit	143
5.	Unpacking and Placing the Unit	144
6.	Refrigerant Piping	146
6.1	Selection of Piping Material	146
6.2	Connecting the Refrigerant Piping	146
6.3	Example of Connection	151
6.4	Leak Test and Vacuum Drying	153
6.5	Pipe Insulation	156
6.6	Additional Refrigerant Charge	156
7.	Field Wiring	159
7.1	Optional Parts	159
7.2	Power Circuit and Cable Requirements	159
7.3	General	160
7.4	Examples	161
8.	Before Operation	166
8.1	Checks Before Initial Start-up	166
8.2	Test Run	167
9.	Caution for Refrigerant Leaks	169

### **Part 3 Installation Manual BS Unit ..... 171**

1.	Safety Considerations	172
2.	Before Installation	175
2.1	Caution Concerning New Refrigerant Series	175
2.2	Precautions	175
2.3	Accessories	176
2.4	Combination	177
3.	Selecting Installation Site	178
4.	Preparations Before Installation	179
5.	BS Unit Installation	180
6.	Refrigerant Piping Work	181
6.1	In Case of Connecting Only One Indoor Unit	183
6.2	When Connecting Multiple Indoor Units	183
6.3	Selection of Pipe Connection Size	183
6.4	Piping Connection	184
7.	Electric Wiring Work	185
7.1	General Instructions	185
7.2	Example for the Whole System	185
7.3	Electrical Characteristics	185
7.4	Specifications for Field Supplied Fuses and Wire	186
7.5	Gist of Field Line Connection	186
7.6	Initial Setting	189
8.	Test Operation	190

## **Part 4 Operation Manual ..... 191**

1. Safety Considerations .....	193
2. What to Do Before Operation.....	197
3. Remote Controller and Changeover Switch: Name and Function of Each Switch and Display.....	198
4. Operation Range.....	200
5. Operation Procedure.....	201
5.1 Cooling, Heating, Automatic, and Fan Only Operation .....	201
5.2 Program Dry Operation .....	203
5.3 Adjusting the Air Flow Direction .....	205
5.4 Programming Start and Stop of the System with Timer .....	206
5.5 Setting the Master Remote Controller .....	207
5.6 Precautions for Group Control System or Two Remote Controller Control System .....	208
6. Optimum Operation .....	209
7. Following Symptoms are not Air Conditioner Troubles .....	210
7.1 The System does not Operate .....	210
7.2 Cool/heat cannot be Changed Over.....	210
7.3 Fan Operation is Possible, but Cooling and Heating do not Work .....	210
7.4 The Fan Strength does not Correspond to the Setting.....	210
7.5 The Fan Direction does not Correspond to the Setting.....	210
7.6 White Mist comes out of a Unit.....	211
7.7 Noise of Air Conditioners.....	211
7.8 Dust comes out of the Unit.....	212
7.9 The Units can Give off Odours .....	212
7.10 The Outdoor Unit Fan does not Spin.....	212
7.11 The Display Shows “88” .....	212
7.12 The Compressor in the Outdoor Unit does not Stop after a Short Heating Operation.....	212
7.13 The Inside of an Outdoor Unit is Warm even when the Unit has Stopped.....	212
8. Troubleshooting .....	213

## **Part 5 Precautions for new Refrigerant (R401A) ..... 215**

1. Precautions for New Refrigerant (R410A).....	216
1.1 Outline .....	216
1.2 Refrigerant Cylinders.....	217
1.3 Service Tools.....	218

## **Index ..... i**

## **Drawings & Flow Charts ..... iii**



# Part 1

## General Information

1. Product Outline .....	2
1.1 Model Names of Indoor/Outdoor Units.....	2
1.2 External Appearance.....	3
1.3 Model Selection.....	4
2. Points to Bear in Mind at the System Design.....	5
2.1 Points Relating to the Performance of the Air Conditioning Units .....	5
2.2 The Installation is of Vital Importance .....	7
2.3 Striking a Balance between System Installation and General Construction Work (Comprehensive Flow Chart) .....	8
2.4 Points to Bear in Mind when Preparing the Contract Drawings .....	9
3. Installation .....	13
3.1 Step by Step Installation Procedure .....	13
3.2 Work Involved in Individual Operations and Points to be Borne in Mind....	14
4. Test Operation .....	63
4.1 Procedure and Outline .....	63
4.2 Operation When Power is Turned On .....	66
4.3 Outdoor Unit PC Board Layout.....	67
4.4 Field Setting .....	68
5. Caution for Refrigerant Leaks .....	96
5.1 Caution for Refrigerant Leaks .....	96
6. Hand Over to Customer .....	98
6.1 Operational Steps.....	98
7. Appendix .....	99
7.1 Operating Noise of Indoor Units .....	99
7.2 Allowable Piping Length.....	101
7.3 Refrigerant branch kit selection.....	104
7.4 Pipe size selection.....	106
7.5 How to calculate the additional refrigerant to be charged .....	107
7.6 REFNET Pipe Connections for VRV R410A Series .....	109
7.7 VRV Inspection Sheet .....	114
7.8 Piping System Diagrams .....	118
7.9 Wiring Diagrams.....	121
7.10 Bad Examples and Good Examples in Installation.....	123

# 1. Product Outline

## 1.1 Model Names of Indoor/Outdoor Units

### Indoor Units

Type		Model Name						Power Supply
Ceiling Mounted Cassette Type (Multi Flow)	FXFQ	12M	18M	24M	30M	36M	—	VJ
Ceiling Mounted Built-In Type	FXSQ	12M	18M	24M	30M	36M	48M	
Ceiling Mounted Duct Type	FXMQ	—	—	—	30M	36M	48M	
Wall Mounted Type	FXAQ	12M	18M	24M	—	—	—	
Floor Standing Type	FXLQ	12M	18M	24M	—	—	—	
Concealed Floor Standing Type	FXNQ	12M	18M	24M	—	—	—	

### BS Units

Type		Model Name		Power Supply
Heat Recovery Series	BSVQ	36M	60M	VJ

### Outdoor Units (Inverter Series)

Series		Model Name		Power Supply
Inverter	Heat Recovery	REYQ	96M	TJ

VJ: 1 $\phi$ , 208~230V, 60Hz

TJ: 3 $\phi$ , 208~230V, 60Hz



## 1.2 External Appearance

### 1.2.1 Indoor Units

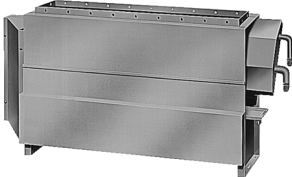
<p>Ceiling mounted cassette type (Multi flow)</p> <p>FXFQ12MVJU FXFQ18MVJU FXFQ24MVJU FXFQ30MVJU FXFQ36MVJU</p> 	<p>Wall mounted type</p> <p>FXAQ12MVJU FXAQ18MVJU FXAQ24MVJU</p> 
<p>Ceiling mounted built-in type</p> <p>FXSQ12MVJU FXSQ18MVJU FXSQ24MVJU FXSQ30MVJU FXSQ36MVJU FXSQ48MVJU</p> 	<p>Floor standing type</p> <p>FXLQ12MVJU FXLQ18MVJU FXLQ24MVJU</p> 
<p>Ceiling mounted duct type</p> <p>FXMQ30MVJU FXMQ36MVJU FXMQ48MVJU</p> 	<p>Concealed floor standing type</p> <p>FXNQ12MVJU FXNQ18MVJU FXNQ24MVJU</p> 
	<p>BS Units</p> <p>BSVQ36MVJU BSVQ60MVJU</p> 

### 1.2.2 Outdoor Units

REYQ96MTJU



## 1.3 Model Selection

### VRV Heat Recovery Series

#### Connectable indoor units number and capacity

HP	8ton
Outdoor unit 1	REYQ96M
Total number of connectable indoor units	10
Total capacity of connectable indoor units (MBtu/h)	48~120

#### Connectable indoor unit

Type		Model Name						Power Supply
Ceiling mounted cassette type (Multi flow)	FXFQ	12M	18M	24M	30M	36M	—	VJU
Ceiling mounted built-in type	FXSQ	12M	18M	24M	30M	36M	48M	
Ceiling mounted duct type	FXMQ	—	—	—	30M	36M	48M	
Wall mounted type	FXAQ	12M	18M	24M	—	—	—	
Floor standing type	FXLQ	12M	18M	24M	—	—	—	
Concealed Floor standing type	FXNQ	12M	18M	24M	—	—	—	

#### Indoor unit capacity

New refrigerant model code	12 type	18 type	24 type	30 type	36 type	48 type
Selecting model capacity	12,000 Btu/h	18,000 Btu/h	24,000 Btu/h	30,000 Btu/h	36,000 Btu/h	48,000 Btu/h
Equivalent output	1 ton	1.5 ton	2 ton	2.5 ton	3 ton	4 ton

Use the above tables to determine the capacities of indoor units to be connected. Make sure the total capacity of indoor units connected to each outdoor unit is within the specified value (kW).

- The total capacity of connected indoor units must be within a range of 50 to 130% of the rated capacity of the outdoor unit.
- In some models, it is not possible to connect the maximum number of connectable indoor units. Select models so the total capacity of connected indoor units conforms to the specification.

#### Unit number and capacity of indoor unit connectable to BS unit

Capacity of BS unit	BSVQ36M	BSVQ60M
Unit number of connectable indoor unit	Five units or less	Eight units or less
Total capacity of connectable indoor unit	Less than 36000 Btu/h	36000 Btu/h or more, less than 60000 Btu/h
Connectable indoor unit	Types 12M to 36M	Types 12M to 48M

## 2. Points to Bear in Mind at the System Design

### 2.1 Points Relating to the Performance of the Air Conditioning Units

A number of points need to be borne in mind at the system design stage in order to ensure the mechanical efficiency of the air conditioning units.

**1. Path of refrigerant piping between outdoor and indoor units, height difference and pipe length.**

- Path of refrigerant piping should be determined such that length of piping is kept to a minimum.
- Piping should be kept within permissible limits in terms of length and height difference.

**2. Positioning of outdoor unit**

- Position such that maintenance and repairs can be carried out. (leave room for servicing)
- Avoid reduction of airflow and short circuiting

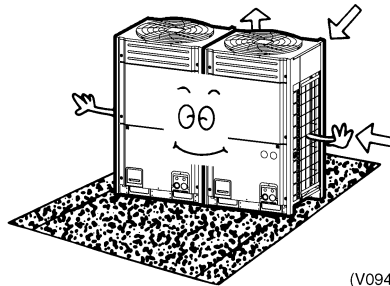

(V0948)

- Avoid reduction of airflow and short circuiting

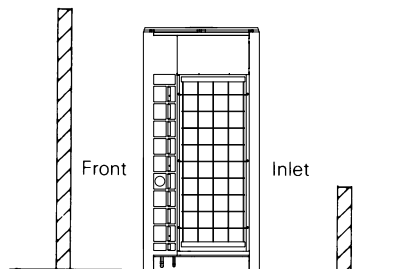

(V0949)

**3. Positioning of indoor unit**

- Position such that maintenance and repairs can be carried out. (inspection port positions and size check)
- Avoid short circuiting
- Ensure sufficient drain pipe gradient (need for drain-up kit etc.)
- In the case of a ceiling mounted type make sure ceiling depth is sufficient (need for high performance filter, etc.)

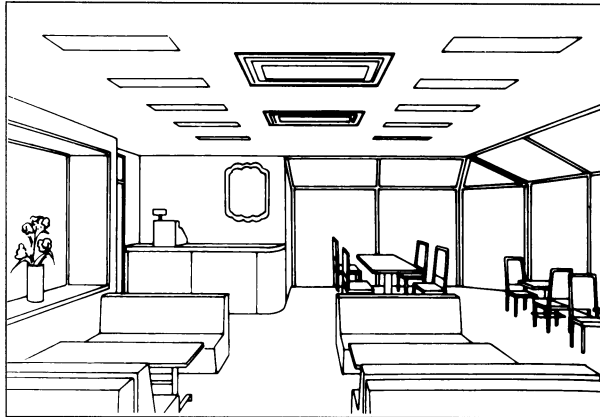

(V0951)

## 2.2 The Installation is of Vital Importance

The analysis of major installation problems experienced during the year of 1988 is shown below;

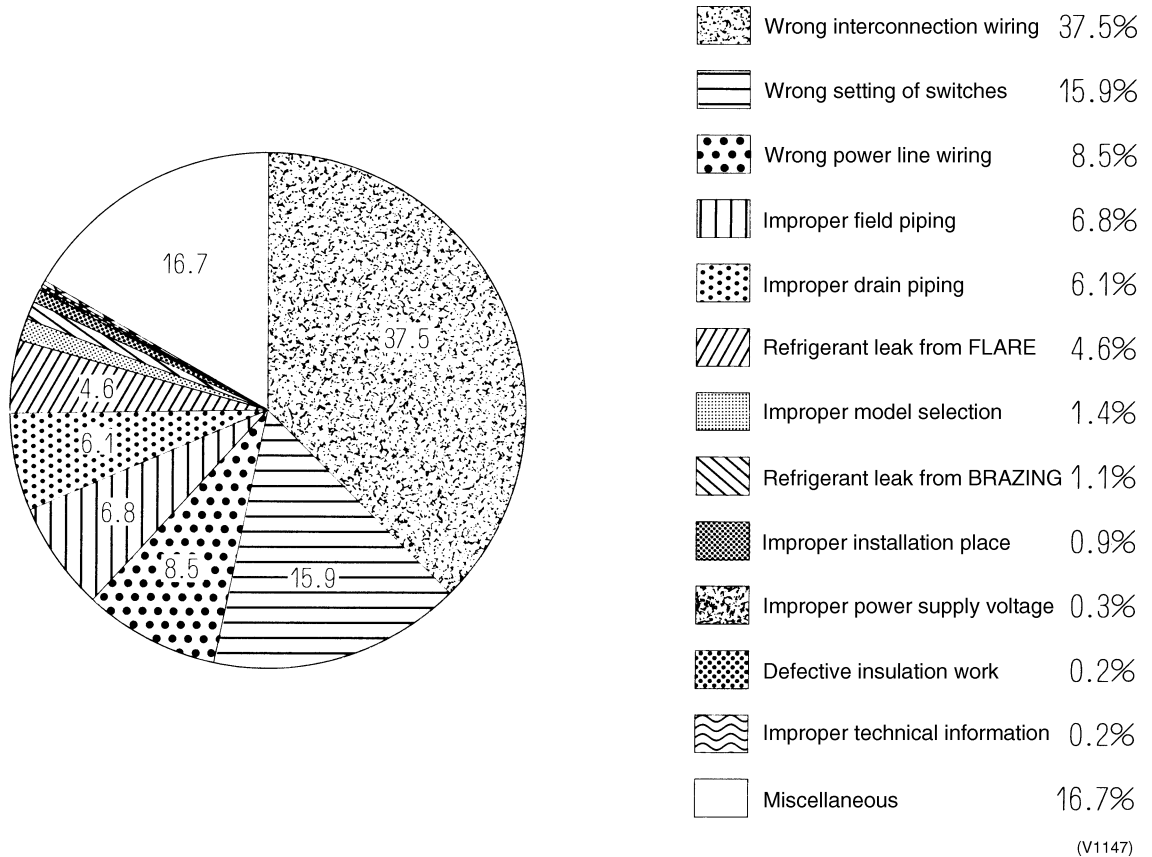

How these installation problems affect an equipment are shown below:

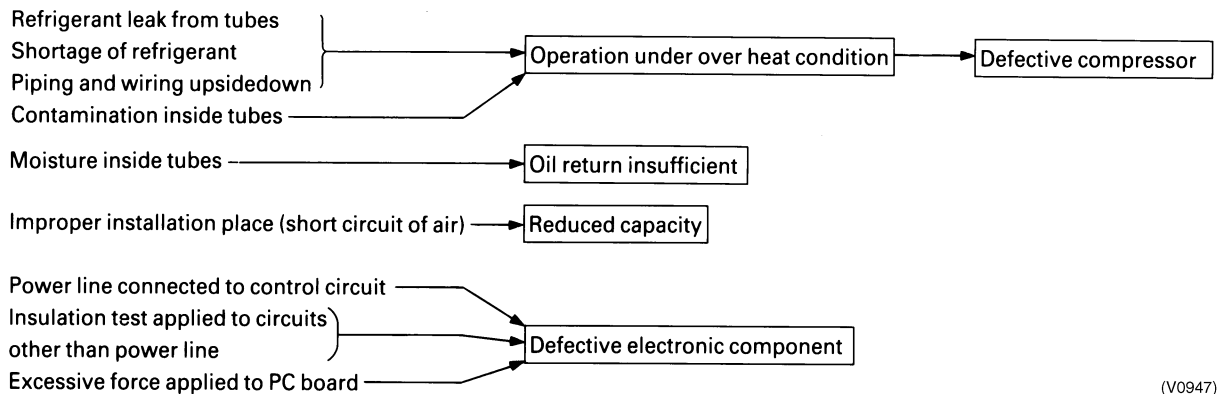

## 1.3 Model Selection

### VRV Heat Recovery Series

#### Connectable indoor units number and capacity

HP	8ton
Outdoor unit 1	REYQ96M
Total number of connectable indoor units	10
Total capacity of connectable indoor units (MBtu/h)	48~120

#### Connectable indoor unit

Type		Model Name						Power Supply
Ceiling mounted cassette type (Multi flow)	FXFQ	12M	18M	24M	30M	36M	—	VJU
Ceiling mounted built-in type	FXSQ	12M	18M	24M	30M	36M	48M	
Ceiling mounted duct type	FXMQ	—	—	—	30M	36M	48M	
Wall mounted type	FXAQ	12M	18M	24M	—	—	—	
Floor standing type	FXLQ	12M	18M	24M	—	—	—	
Concealed Floor standing type	FXNQ	12M	18M	24M	—	—	—	

#### Indoor unit capacity

New refrigerant model code	12 type	18 type	24 type	30 type	36 type	48 type
Selecting model capacity	12,000 Btu/h	18,000 Btu/h	24,000 Btu/h	30,000 Btu/h	36,000 Btu/h	48,000 Btu/h
Equivalent output	1 ton	1.5 ton	2 ton	2.5 ton	3 ton	4 ton

Use the above tables to determine the capacities of indoor units to be connected. Make sure the total capacity of indoor units connected to each outdoor unit is within the specified value (kW).

- The total capacity of connected indoor units must be within a range of 50 to 130% of the rated capacity of the outdoor unit.
- In some models, it is not possible to connect the maximum number of connectable indoor units. Select models so the total capacity of connected indoor units conforms to the specification.

#### Unit number and capacity of indoor unit connectable to BS unit

Capacity of BS unit	BSVQ36M	BSVQ60M
Unit number of connectable indoor unit	Five units or less	Eight units or less
Total capacity of connectable indoor unit	Less than 36000 Btu/h	36000 Btu/h or more, less than 60000 Btu/h
Connectable indoor unit	Types 12M to 36M	Types 12M to 48M

**Note:**

1. The division of the work should be thoroughly clarified. (This applies particularly to work relating to the connection of control wiring, fitting of remote controller and central control panel, boundary work on areas such as connection of drain piping and humidification supply piping, inspection and foundation)
2. Keep a constant check on the progress of the construction work to avoid deviations from the air conditioning work schedule.
3. For sleeve and insert work the positions of ceiling girders should be confirmed and sleeve and insert requirement, hole diameters, positioning and numbers decided. This is particularly important in the case of sleeves for drain piping.

## 2.4 Points to Bear in Mind when Preparing the Contract Drawings

The following points should be borne in mind when preparing the contract drawings from the original drawings and the execution drawings.

The contract drawings for the air conditioning system are blueprints for the performance of the necessary work which are drawn up on the basis of the original drawings in such a way that a working balance is achieved between the specific requirements of each individual aspect of the work.

### Contract Drawing

Objectives include:

- The drawings should be easily comprehensible to those carrying out the work.
- The contents of the drawings should not be subject to subsequent alteration.

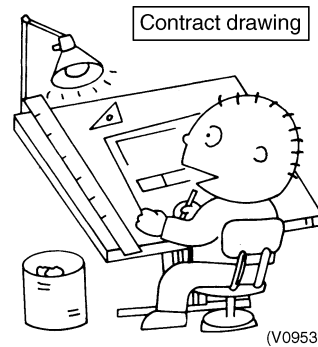

The following is a list of the main points to be considered when preparing contract drawings for the **VRV** and should be used as a reference during this stage of the work:

### 2.4.1 At the Contract Drawing Stage the Following Points are Critical!!

	Check points	
Arrangement of units	<ol style="list-style-type: none"> <li>1. Have you left the access passages clear and allowed sufficient room for servicing?</li> <li>2. Have you taken full account of the possibility of short circuits? (Both indoor and outdoor units)</li> <li>3. Can the air filters be replaced easily?</li> <li>4. Have you indicated the size and location of the ceiling inspection ports? (Make sure there no other installations in the area above)</li> <li>5. Have you taken into account the depth of the installation area? (In case of ceiling built-in type)</li> <li>6. Have you specified the position of the indoor unit clearly? (Have you taken full account of relevant features of the local ventilation, humidity and lighting?)</li> </ol>	
Refrigerant piping	<ol style="list-style-type: none"> <li>1. Is the piping system correctly connected?</li> <li>2. Are the rise and fall pipes correctly connected?</li> <li>3. Are the lengths and height differences of the pipes within the recommended limits?</li> </ol>	
Operational control	<ol style="list-style-type: none"> <li>1. Are the interconnections between the piping and wiring of the indoor and outdoor units clearly shown?</li> <li>2. Are the numbers of the local setting switches clearly shown? (Group No. and Unit No.)</li> <li>3. Are the wiring connections between the remote controller and the centralized and remote controls clearly shown? <b>Refer to the notes relating to the preparation of the control wiring system diagrams (see next page)</b></li> <li>4. Are the different types of wires clearly marked?</li> <li>5. Are the any problems with the way the power supply cables and control wiring have been separated or bound together?</li> <li>6. Are the inter-floor connections of the control wiring correct?</li> <li>7. Is the position of the remote controller clearly marked?</li> </ol>	
Miscellaneous	<ol style="list-style-type: none"> <li>1. Have you checked the gradient of the drain piping? (Must be at least 1/100)</li> </ol>	

(Example of a contract drawing)

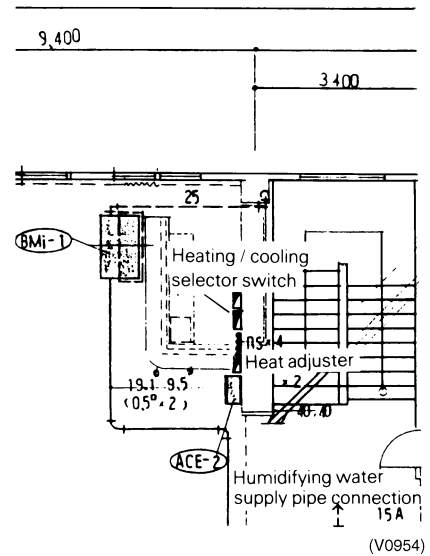



## 2.4.2 Main Considerations in Preparation of Control Circuit Diagrams

In addition to the design of the appropriate this system configuration it is also essential that the control system be made amply clear. If the system is designed and installed without a clear, comprehensive plan then problems are inevitably going to occur during the test run.

Servicing too will become much more time consuming than necessary. However, if control circuit diagrams are prepared along with the contract drawings in order to make the total system clearly visible then the essential points relating to the electrical connections will be easily understood, the test run will go off without a hitch and the whole system will be rendered fully effective.

### Step 1: Compiling a System List

1. Mark each outdoor unit with a code.
2. Add field settings and data for outdoor units, and outdoor unit No. if using sequential start.
3. Add the model number of each indoor unit connected to each refrigerant circuit.
4. Assign each indoor unit a code.
5. Fill in the location of each indoor unit.
6. Group indoor units controlled by one or two remote controllers. (group or individual control).
7. Assign central group Nos. if using centralized control.
8. Add field settings and optional equipment for indoor units.
9. Add unit No. if making separate field settings for each indoor unit under group control.



**Note:** With the VRV R410A Heat Recovery Series, unit No. is determined through automatic addressing, therefore readout unit Nos. after activating the power.

Example: System list

Outdoor Unit		Indoor Unit						
Model Name (code)	Field Settings	Model Name	System Name	Location	Remote Controller Group	Centralized Control Group No.	Unit No.	Optional equipment, field settings, etc.
REYQ96M (PAC1)	Cool/Heat selector: Indoor unit Low noise operation (L.N.O.P): Individual control Sequential start: ON Defrost: Earlier Sequential start No.	FQ12M	2F01	2nd floor office	A	1-00		
		SQ18M	2F02	2nd floor office	A	(1-00)		
		FQ18M	2F03	2nd floor office	A	(1-00)		
		MQ30M	2F04	2nd floor office	B	1-01		
		FQ12M	2F05	2nd floor office	B	(1-01)		
REYQ96M (PAC2)	Cool/Heat selector: Indoor unit Low noise operation (L.N.O.P): Individual control Sequential start: ON Defrost: Earlier	SQ12M	3F01	3rd floor office	C	1-02		
		FQ24M	3F02	3rd floor office	C	(1-02)		
		SQ24M	3F03	3rd floor office	C	(1-02)		
		FQ24M	3F04	3rd floor office	D	1-03		

For details on field settings and centralized control group No., refer to the installation manual and system reference materials.

**Step 2:  
Preparation of the  
Control Circuit  
Diagrams**

The following sequence should be followed in order to prepare control circuit diagrams in accordance with the system list which has already been completed:

- ① Diagrams should be prepared for each individual outdoor unit. The outdoor unit model number should be inserted into the diagram. (REYQ96M)
  - ② Insert name of refrigerant system. (PAC1, PAC2)
  - ③ Insert name of indoor unit. (FXFQ12M→FQ12M)
  - ④ Insert system name of indoor unit.
  - ⑤ Insert installation position. (Do this when demarcation is possible)
  - ⑥ Insert remote controller control wiring. (Group) Indicated by solid line. ....Solid line.
  - ⑦ Insert centralized control wiring. ....Dotted line
  - ⑧ Insert Group No. (G No. for each indoor unit with U No. 0)
- The control circuit diagrams are now complete.

Example: Control circuit diagram

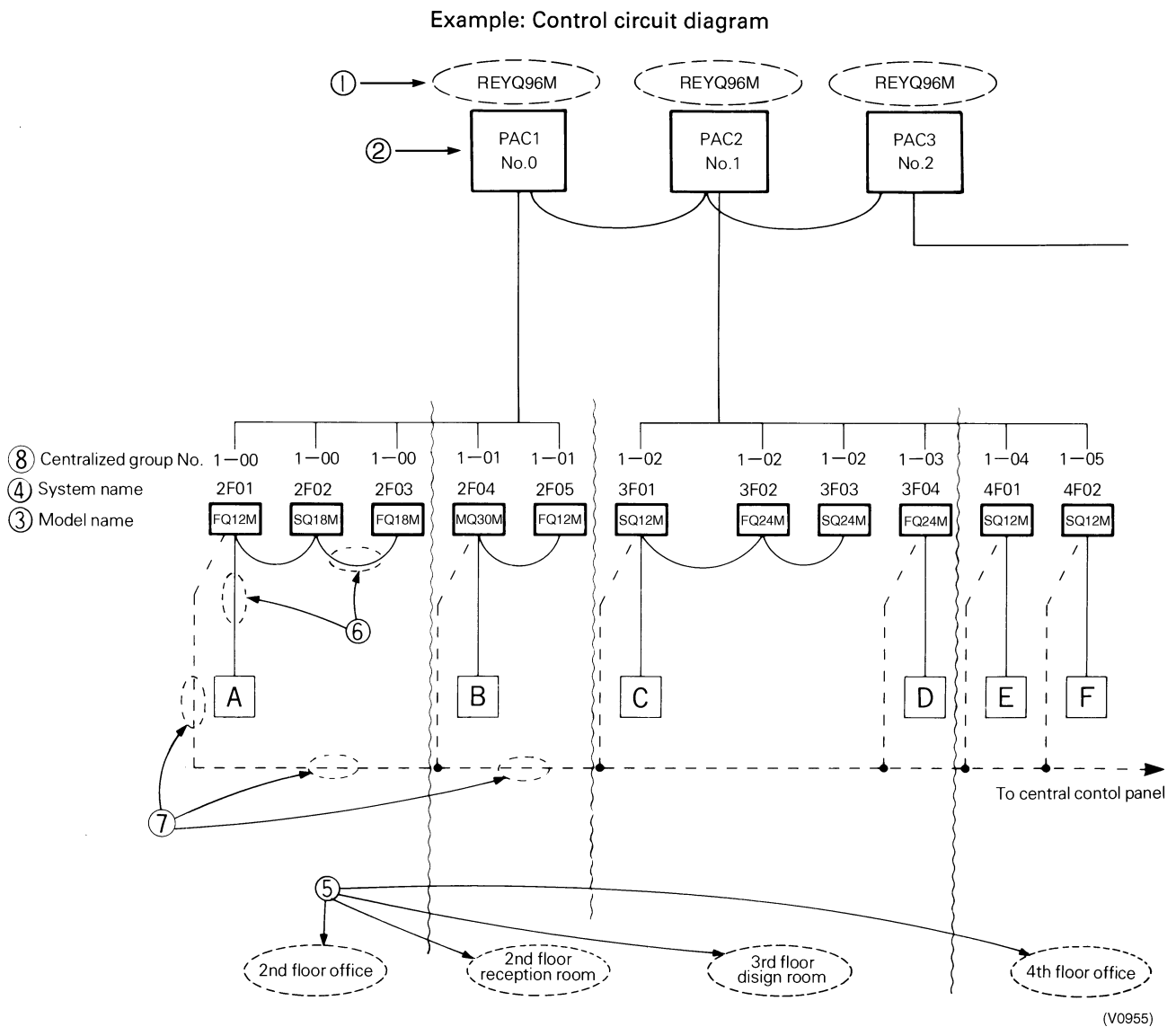

## 3. Installation

### 3.1 Step by Step Installation Procedure

	<Operations>	<Points>
Prework	Determination of division of work	Indicate clearly who is to be responsible for switch settings
	Preparation of contract drawings	Make relationship between outdoor, indoor, remote controller and option connections clear. (Prepare control circuit diagrams)
Work	Sleeve and insert work	Take account of gradient of drain piping
	Installation of indoor unit	Check model name to make sure the fitting is made correctly
	Refrigerant piping work	Special attention to dryness, cleanness and tightness
	Drain pipe work	Adjust to downward gradient
	Duct work	Make sure airflow is sufficient.
	Heat insulation work	Make sure no gaps are left where the insulating materials are joined
	Electrical work (connection circuits and drive circuits)	Multiple core cable must not be used. (Suitable cable should be selected)
	Setting of indoor unit setting switches	Must be carried out in strict accordance with control circuit diagrams
	Outdoor unit foundation work	The foundation must be level
	Installation of outdoor unit	Avoid short circuits and ensure sufficient space is allowed for servicing
	Setting of outdoor unit setting switch	Must be carried out in strict accordance with control circuit diagrams (Sequence start, low noise input, Cooling/Heating selection refrigerant piping length etc.)
	Air tight test	In the final check for 24 hours at 551 psi there must be no drop in pressure
	Vacuum drying	The vacuum pump used must have a capacity of reaching at least 5 mmHg
	Additional charge of refrigerant	The amount of refrigerant to be added to the unit should be calculated and written on the "Added Refrigerant" plate and attached to the rear side of the front cover.
	Fit decoration panels	Make sure there are no gaps left between the facing materials used on the ceiling
	Test run adjustment	Run each indoor unit in turn to make sure the pipework has been fitted correctly
	Transfer to customer with explanation	Explain the use of the system as clearly as possible to your customer and make sure all relevant documentation is in order

(V1351)

The above list indicates the order in which the individual work operations are normally carried out but this order may be varied where local conditions warrant such a change

## 3.2 Work Involved in Individual Operations and Points to be Borne in Mind

### 3.2.1 Sleeve and Insert Work

#### ■ Operational steps

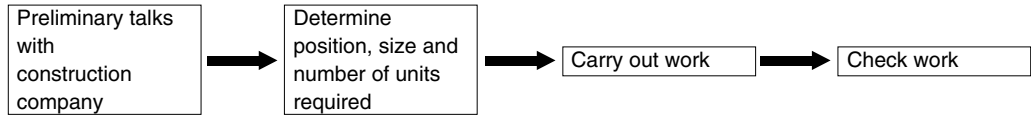

(V0957)

#### Positioning of the Pipe Holes

- The through holes for the drain piping should be positioned such that the pipes have a downward gradient. (The gradient must be at least 1/100. The thickness of the insulating materials must also be taken into consideration.)
- The diameter of the through holes for the refrigerant piping should include an allowance for the thickness of the heat insulation materials. (It is a good idea to think of the liquid and gas pipes as pairs.)
- Attention should be paid to the construction of the beam themselves since there are sometimes parts of the beam which cannot be used to accommodate through holes.

**Example:** Through holes in a reinforced concrete beam

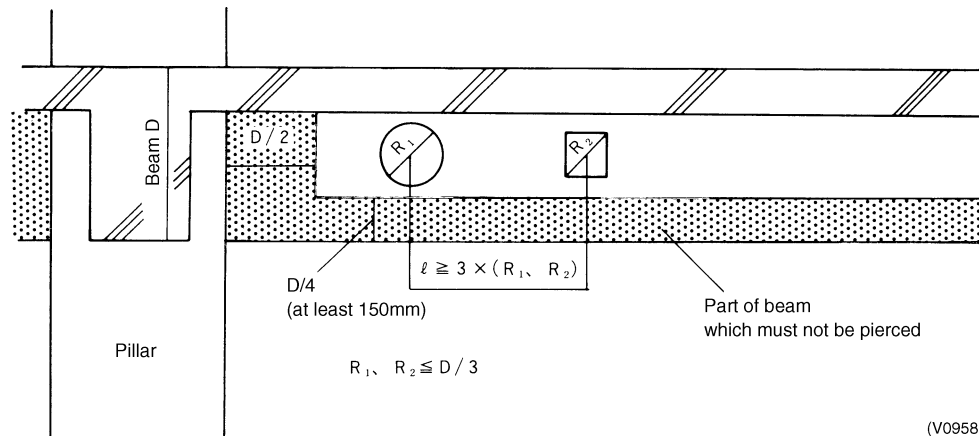

(V0958)

## Positioning the Insert

- a) An insert is a metal tool which is inserted into a floor or a beam before the concrete is set such that fittings such as ducts, pipes or suspension bolts for hanging units can be fitted into place later. **The positions of the inserts must be decided early.**

**Example:** Steel insert

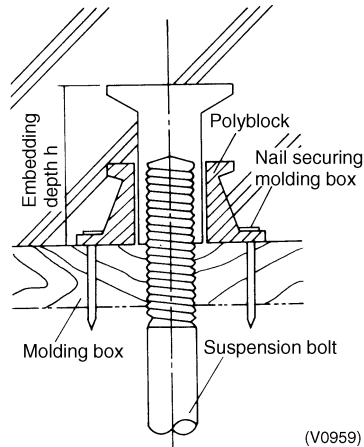

### Important point:

1. The weight of the fitting to be suspended must be taken into account when choosing the insert.

## 3.2.2 Installation of Indoor Unit

### ■ Operational steps

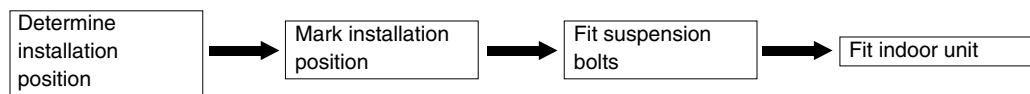

(V0960)

## Positioning

3 essential points when installing an indoor unit

1. Height: Take care to account for final ceiling facing surface level
2. Level: Level fitting is essential. (within  $\pm 1$  degree of horizontal)

3. Direction: The unit must be fitted in line with the ultimately visible ceiling joints

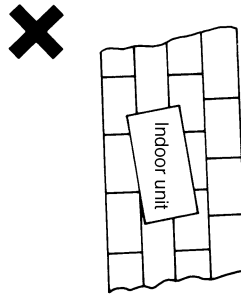
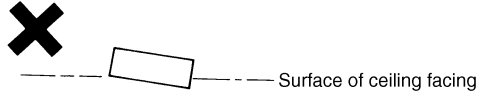
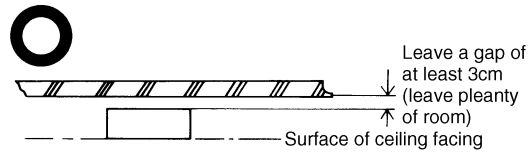

(V0961)

#### Important points

1. The suspension bolts must be strong enough to support the weight of the indoor unit.
2. Optional features must be added to the indoor unit prior to installation.
3. The model name should be checked prior to installation.
4. Take care to align the main unit correctly. (Bearing in mind piping layout and direction of blow out)
5. Leave sufficient space for servicing to be carried out.
6. Make inspection holes for model which need them.
7. Fit the unit to ensure proper drainage.

Service Space for Indoor Units

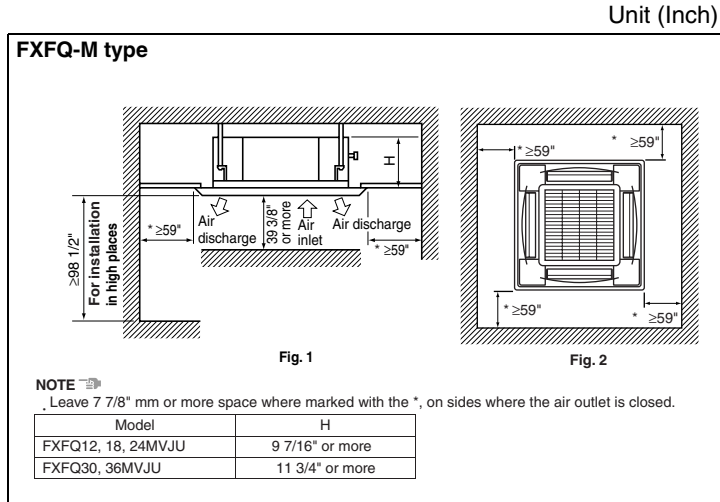

**i Note:** Above figure means minimum value. Please keep these value at least.

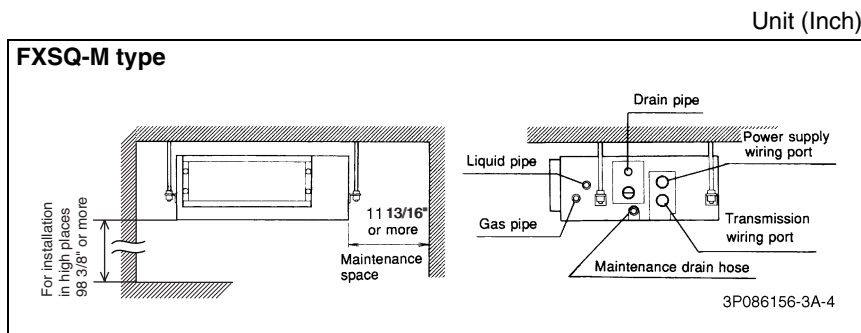

**i Note:** Above figure means minimum value. Please keep these value at least.

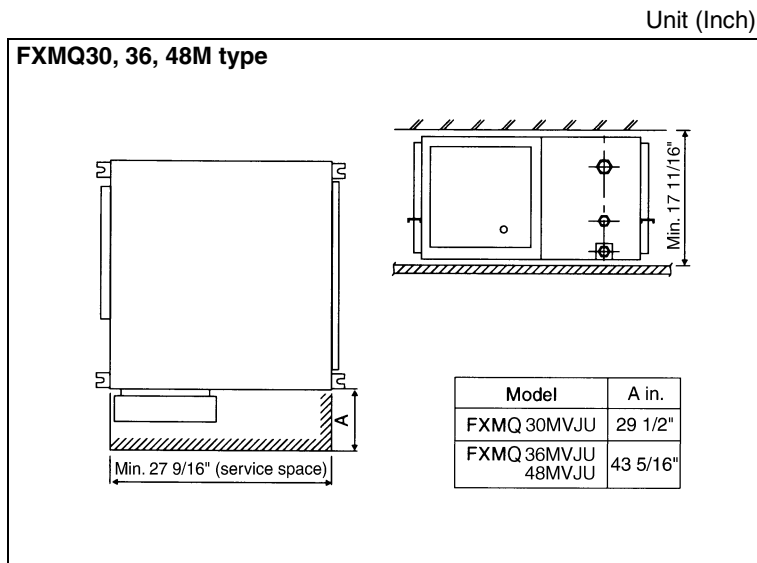

**i Note:** Above figure means minimum value. Please keep these value at least.

Unit (Inch)

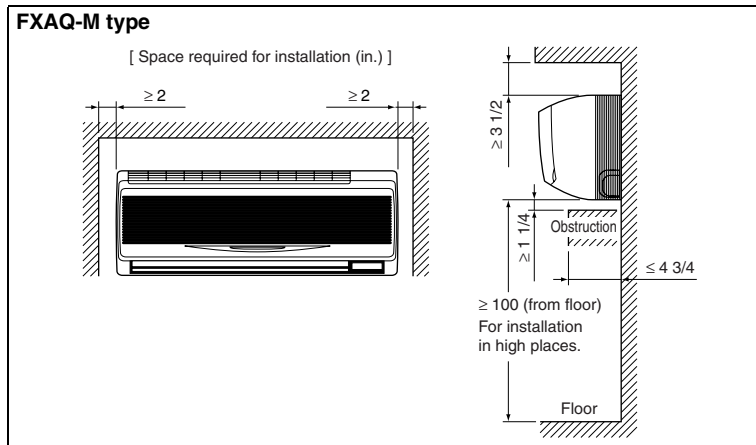

**i Note:** Above figure means minimum value. Please keep these value at least.

Unit (Inch)

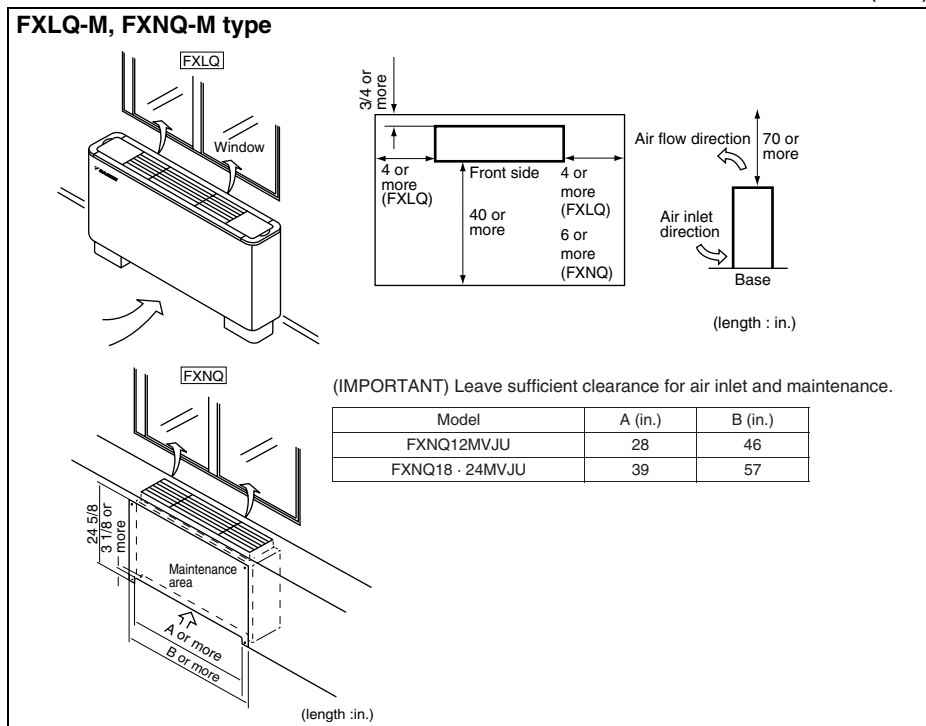

**i Note:** Above figure means minimum value. Please keep these value at least.



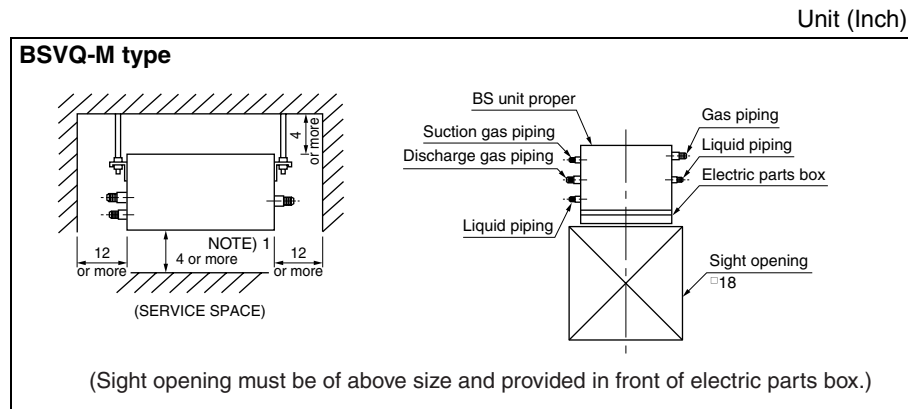

**Note:** Above figure means minimum value. Please keep these value at least.

### 3.2.3 Refrigerant Pipe Work

■ Operational steps

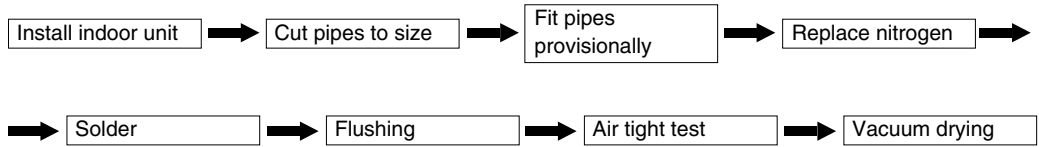

(V0963)

### The 3 Principles of Refrigerant Piping

The “3 principles of refrigerant piping” must be strictly observed

	Cause of problem	Actoin to avoid problem
Dry	<ul style="list-style-type: none"> <li>● Rainwater, work water, etc. gets into pipes from outside</li> <li>● Moisture generated inside pipes due to condensation</li> </ul>	
Clean	<ul style="list-style-type: none"> <li>● Formation of oxides inside pipes during soldering</li> <li>● Dirt, dust or other extraneous material gets into pipes from outside</li> </ul>	
Air tight	<ul style="list-style-type: none"> <li>● Leak from soldered area</li> <li>● Leak from flared area</li> <li>● Leak from flange area</li> </ul>	

(V0964)

The 3 principles of refrigerant piping

Dry	Clean	Air tight
Make sure there is no moisture inside the pipes	Make sure there is no dirt inside the pipe	Make sure the refrigerant does not leak out
<p>(V0965)</p>	<p>(V1148)</p>	<p>(V1149)</p>

### Method for Replacing Nitrogen (Brazing)

If brazing work is carried out without passing nitrogen gas through the pipes which are being brazed then this allows the formation of oxidation bubbles on the inside surface of the pipes. These oxidation bubbles are then carried along inside the pipes to cause damage to various members of the system such as valves or compressors and the system ceases to function properly.

In order to avoid this problem **nitrogen is passed through the pipes while the soldering work is being carried out**. This operation is known as nitrogen replacement. (Air is replaced by nitrogen)

This is **standard work practice for all brazing work**.

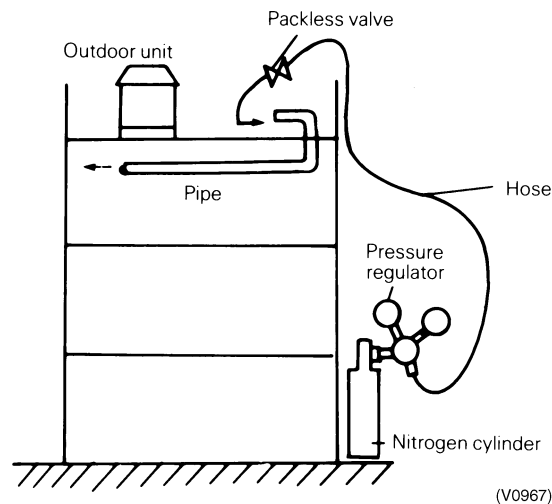
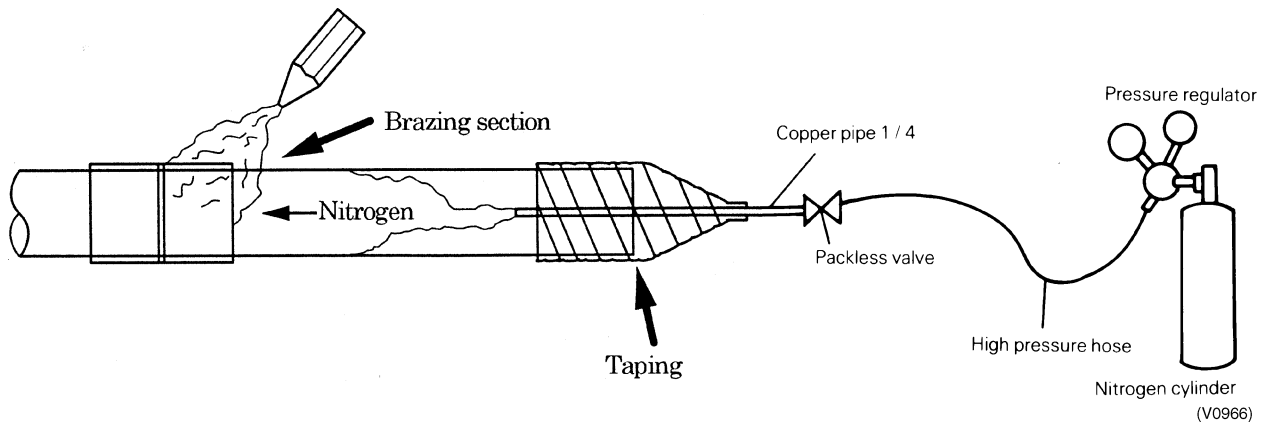

#### Important points:

1. The gas used must be nitrogen (oxygen, carbon dioxide and flon should not be used.)
2. A pressure regulator must be used.

**Covering of Refrigerant Pipes**

**Covering is an extremely important operation as it prevents water, dirt or dust from getting inside the pipes.** Moisture inside the pipes was a constant source of trouble in the past. The utmost care is required to nip this problem in the bud.

**The end of each pieces of pipe must be covered.** “Pinching” is the most effective method but “taping” is an simple alternative which may be used according to the work area and term of work.

Location	Term of Work	Covering Method
Outdoors	1 months or more	Pinching
	Less than 1 months	Pinching or taping
Indoors	Irrelevant	Pinching or taping

1. Pinching method

The end of the copper pipe is squeezed together and the gap brazed.

2. Taping method

The end of the copper pipe is covered with PVC tape (vinyl tape).

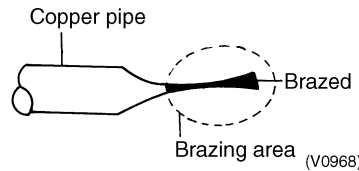

<Taping method>

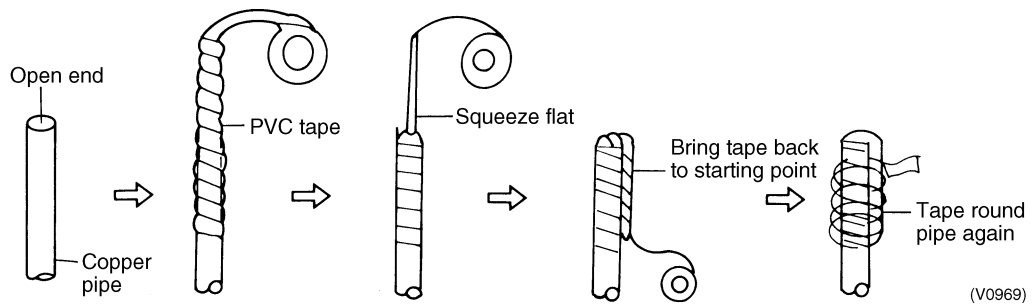

Particular care should be taken during the following operations:

- When passing copper pipe through a penetration hole (Dirt easily gets into the pipe).
- When copper pipe is located outside (Rainwater gets in)  
(Special care is needed when the pipes are standing vertically outside)

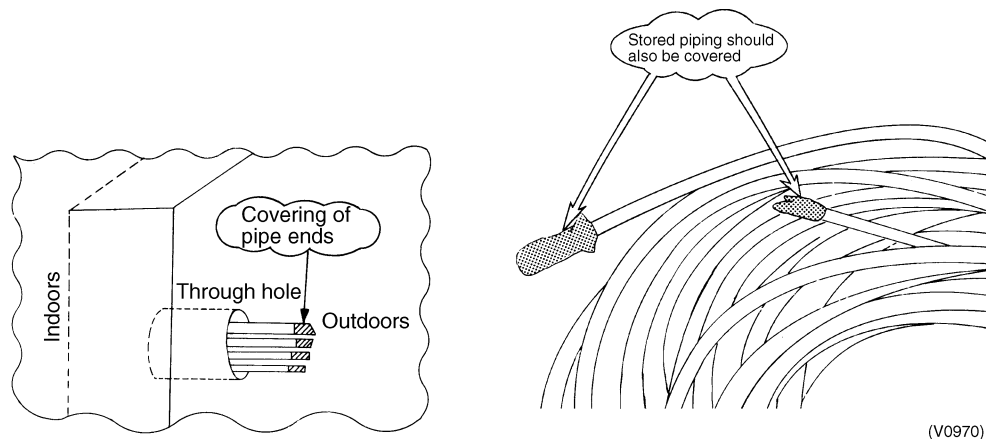

## Refrigerant Pipe Flushing

**Flushing is a method of cleaning extraneous matter out of pipes using pressurized gas.**

### [3 major effects]

1. Removal of oxidation bubbles formed inside copper pipes when “nitrogen replacement is insufficient” during soldering work
2. Removal of extraneous material and moisture from pipes when covering has been insufficient
3. Checks connections in pipes linking outdoor and indoor units (Both liquid and gas pipes)

### [Example of procedure]

1. Set pressure regulator on nitrogen cylinder.  
\*The gas used must be nitrogen.  
(There is a danger of condensation if freon or carbon dioxide are used and oxygen carries the risk of explosions.)

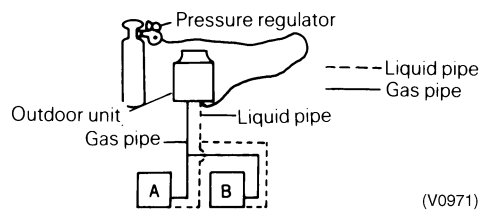

2. Connect the charge hose from the pressure regulator to the service port on the liquid pipe side of the outdoor unit.
3. Fit blanking plugs to all indoor units (B) other than unit A.

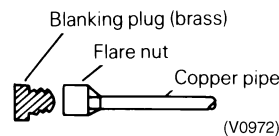

4. Open the main valve on the nitrogen cylinder and set the pressure regulator to 72 psi.

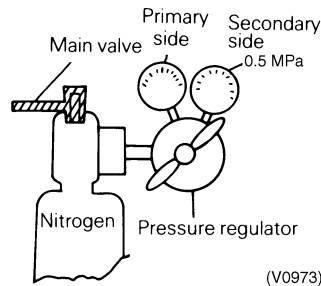

5. Check that the nitrogen is passing through the unit A liquid pipe.

6. Flushing.

- Block the end of the pipe with the insulation of your hand.

↓

- When the gas pressure becomes too great to contain remove insulation quickly. (First flush)

↓

- Block the end of the pipe with insulation again.

↓

(Carry out second flushing)

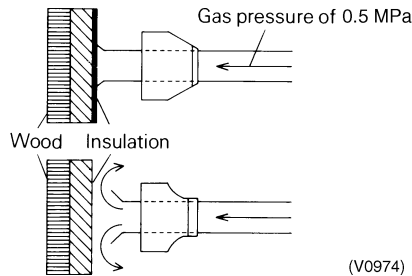

(The nature and amount of the extraneous material inside the pipe can be checked during flushing by placing a rag lightly over the end of the pipe. In the unlikely case that even a small quantity of moisture is found then the inside of the pipe should be dried out thoroughly.)

Action:

1. Flush the inside of the pipe with nitrogen gas. (Until such time as the moisture disappears.)
2. Carry out a thorough vacuum drying operation. (See page 34)
  - ① Close the main valve on the nitrogen cylinder.
  - ② Repeat the above operation for unit B.
  - ③ When the liquid pipe operations have been completed then do the same with the gas pipes.

**Choice of Materials for Refrigerant Piping**

a) Refrigerant piping

- The piping used must meet the requirements of the JIS standard or equivalent. (Size, material, thickness, etc.)

Specification: **Oxidized phosphorous seamless copper pipe**

- Long pipe lengths or coiled pipe (copper pipe with heat insulation coating) should be used to avoid the necessity for frequent brazing.

(\* Make sure the thickness and material shall be selected in accordance with following table.)

■ **Size of Refrigerant Piping**

Outside Diameter (mm)	Material
φ1/4 (φ6.4)	0
φ3/8 (φ9.5)	0
φ1/2 (φ12.7)	0
φ5/8 (φ15.9)	0
φ3/4 (φ19.1)	1/2H
φ7/8 (φ22.2)	1/2H

\*The thickness and material shall be selected in accordance with local code.

b) Brazed joints and special branches

1. General use (L bend joint, socket joint, T joint, etc.)

- Joints must meet the requirements of the relevant JIS standard. (Size, materials, thickness, etc.)

2. Special branches

- The Daikin outdoor unit multi connection kit, REFNET joint, REFNET header or Reducing socket should be used.

**Note:**

1. The division of the work should be thoroughly clarified. (This applies particularly to work relating to the connection of control wiring, fitting of remote controller and central control panel, boundary work on areas such as connection of drain piping and humidification supply piping, inspection and foundation)
2. Keep a constant check on the progress of the construction work to avoid deviations from the air conditioning work schedule.
3. For sleeve and insert work the positions of ceiling girders should be confirmed and sleeve and insert requirement, hole diameters, positioning and numbers decided. This is particularly important in the case of sleeves for drain piping.

## 2.4 Points to Bear in Mind when Preparing the Contract Drawings

The following points should be borne in mind when preparing the contract drawings from the original drawings and the execution drawings.

The contract drawings for the air conditioning system are blueprints for the performance of the necessary work which are drawn up on the basis of the original drawings in such a way that a working balance is achieved between the specific requirements of each individual aspect of the work.

### Contract Drawing

Objectives include:

- The drawings should be easily comprehensible to those carrying out the work.
- The contents of the drawings should not be subject to subsequent alteration.

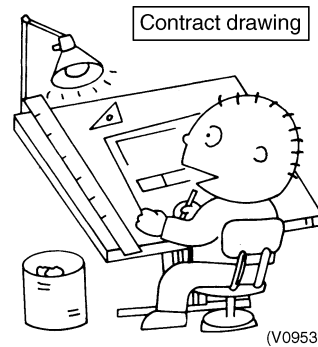

The following is a list of the main points to be considered when preparing contract drawings for the **VRV** System and should be used as a reference during this stage of the work:

**Brazing**

- a) Brazing work should be carried out such that the final result is directed either downwards or sideways. An upward direction should be avoided wherever possible. (to prevent leakage)

<Recommended method>

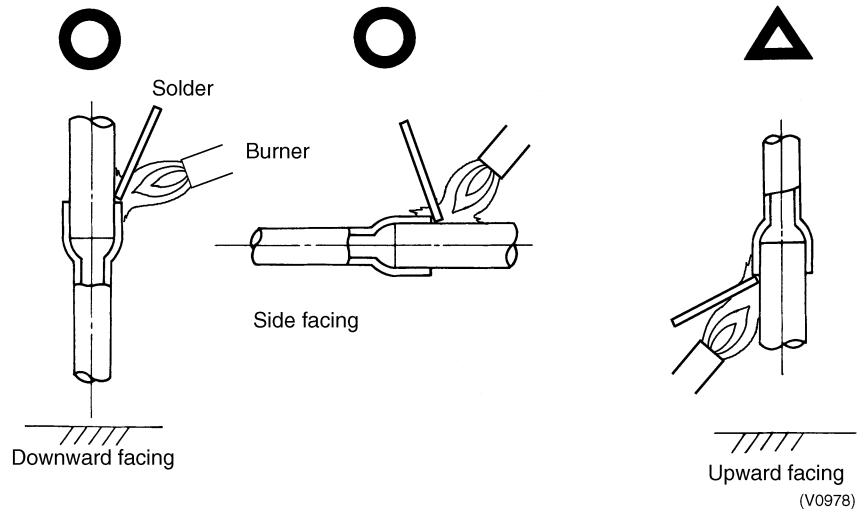

- b) Liquid and gas pipe branches should always be dealt with in the specified way with attention being paid to the direction of the fitting and its angle. (to prevent oil return or drift) For example see page 127.
- c) It is standard working practice to use the nitrogen replacement method when brazing.

**Important points**

1. Every effort must be made to avoid fire. (Clean area where brazing is to be performed and make sure that fire fighting equipment and water are ready to hand.)
  2. Be careful of burns.
  3. Make sure that the gap between the pipe and the joint is correct. (To prevent leaks)
  4. Is the pipe adequately supported?
- As a rule the gaps between supports for horizontal piping (copper pipe) are as follows:

Copper pipe support spacing (From HASS 107-1977)

Nominal diameter	φ1/2 or less	φ7/8
Maximum gap (Inch)	40	60

- The copper pipe should not be secured directly by metal brackets.

**Flare Connection**

- (a) Stiffened pipe must always be annealed at least once prior to the flaring work.
- (b) A pipe cutter must be used to cut the pipe. (A large pipe cutter must be used where the pipe has a large diameter. When cutting a pipe which is too big for the pipe cutter a metal saw may be used but care must be taken to ensure that the debris from sawing does not get into the pipe.)
- (c) Set the flaring tool to make sure the flare size remains within the prescribed limits.

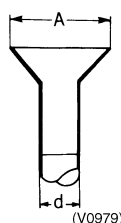

Nominal diameter	External diameter of pipe d (mm)	Pipe widening dimensions A (mm)
1/4	6.35	9.1
3/8	9.52	13.2
1/2	12.7	16.6
5/8	15.88	19.7



### New Rank Compatible Flare Tool

Compared to previous refrigerants, the components of a HFC refrigerant is small. R410A also has a higher pressure than other refrigerants. Therefore, in order to strengthen the intensity of the form and size of the flare section used for R410A (class 2) apparatus, unlike the specification of the conventional refrigerants, it was set up with different standards.

When carrying out flare processing, use a new rank compatible flare tool or a conventional flare tool.

### Flare Gauge (Adapter Corresponding to the New Rank)

When using the later, use a flare gauge to take out the pipe from the gauge bar, adjust it, and then carry out the flare processing.



Size 12mm×72mm  
Thickness 1.0×0.5mm Each

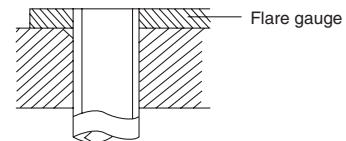

### Size from the dice surface to the copper tip (in mm)

Name	Outer diameter mm	Wall thickness mm	Previous refrigerant (R22, R407C etc.)	R410A
			The conventional flare tool	The conventional flare tool
			Clutch type	Clutch type
1/4	6.35	0.8	0~0.5	1.0~1.5
3/8	9.52	0.8	0~0.5	1.0~1.5
1/2	12.70	0.8	0~0.5	1.0~1.5
5/8	15.88	1.0	0~0.5	1.0~1.5

(d) Coat the inner and outer surface of the flare with refrigerator oil (Ester or ether oil). (this ensures that the flare nut passes smoothly, preventing the pipe from twisting.)

Do not use SUNISO-4GS oil.

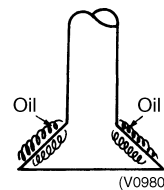

### Important points

1. Burrs should be carefully removed.
2. 2 spanners should be used to grip the flare nuts.
3. The flare nut must be inserted before starting the flaring operation.
4. The appropriate amount of torque should be used to tighten the flare nut.

Standard torques for tightening flare nut ±10%

Size	Torque		
	ft. lbf	(kgf-cm)	(N-cm)
1/4(6.4φ)	10.4~12.7	144~176	1420~1720
3/8(9.5φ)	24.1~29.4	333~407	3270~3990
1/2(12.7φ)	36.5~44.5	504~616	4950~6030
5/8(15.9φ)	45.6~55.6	630~770	6180~7540

5. Check that there is no superficial damage to the surface of the flare.

**Flaring Procedure**

- ① Cut the pipe using a pipe cutter.

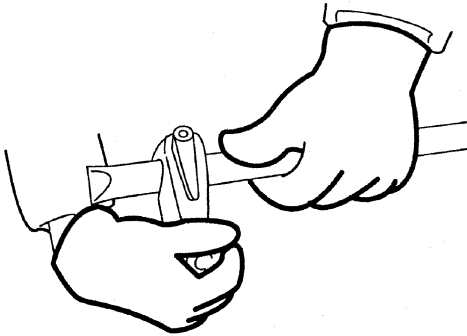

- ② The cut edge has burrs.  
(The amount of burrs becomes larger when the pipe wall is thick.)

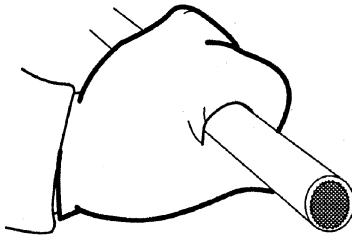

- ③ Remove the burrs using a file.  
(Be careful not to let particles enter the pipe. Point the pipe end downward during filing.)

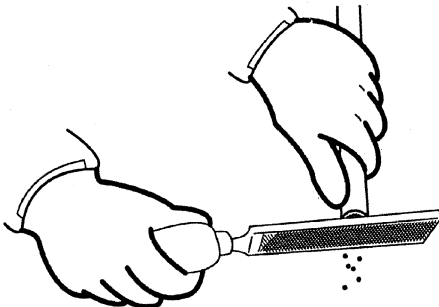

- ④ Remove the burrs using a reamer  
(Be careful not to let particles enter the pipe. Point the pipe end downward during cutting.)

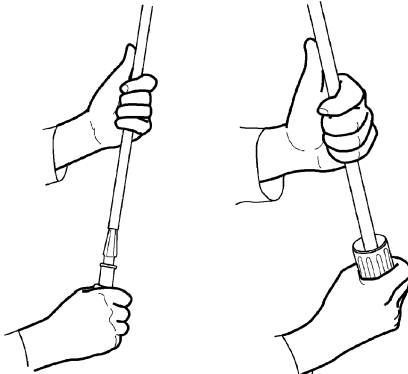

- ⑤ Clean the inside of the pipe.  
(Use a thin stick with a cloth wrapped around it.)

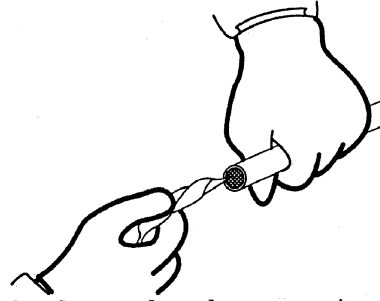

- ⑥ Before flaring, clean the cone section of the flaring tool.

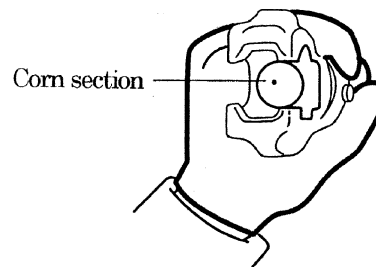

- ⑦ Flare the pipe.  
Rotate the flaring tool 3 or 4 turns after a clicking sound is produced. This results in a clean flared surface.

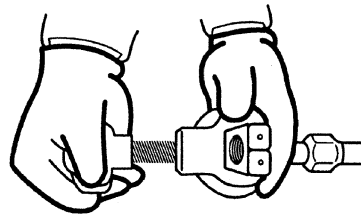

- ⑧ Apply refrigerant oil (Ester or ether oil) on the inside and outside of the flared section. (Do not apply SUNISO oil.)  
(Be careful to keep dust away.)

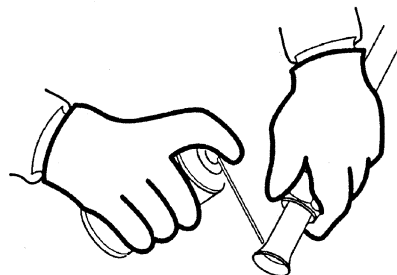

(V1352)

- ⑨ Tighten the flare nut.  
(Use a torque wrench to apply the proper tightening force.)

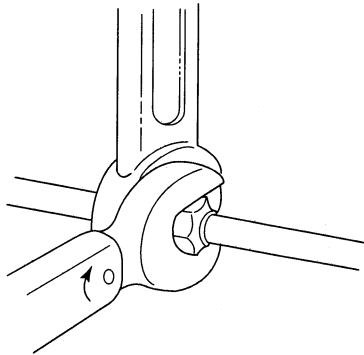

- ⑩ Check for gas leaks.  
(Check at the threaded section of the flare nut for gas leaks.)  
Spray-type gas leak detecting products are available on the market. Soap water may be used to check for leaks, but use only neutral soap to prevent corrosion of the flare nut.  
Be sure to wipe the nut area clean after the gas leak check.

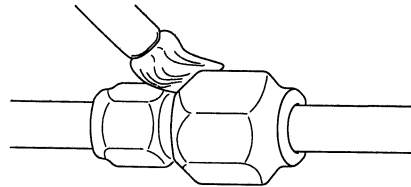

**Tighten the flare nut with proper torque.**  
It takes a lot of experience to tighten the flare nut properly without the use of a torque wrench.

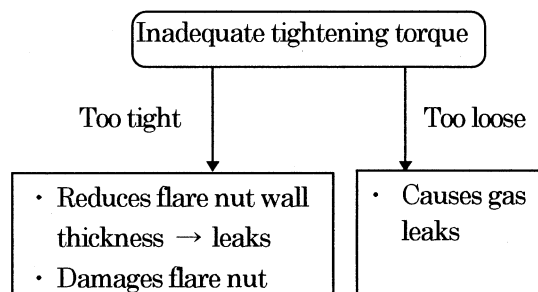

(V0984)

**Not  
recommendable  
but in case of  
emergency**

You must use a torque wrench but if you are obliged to install the unit without a torque wrench, you may follow the installation method mentioned below.

**After the work is finished, make sure to check that is no gas leak.**

When you keep on tightening the flare nut with a spanner, there is a point where the tightening torque suddenly increases. From that position, further tighten the flare nut the angle shown below:

Pipe size in. (mm)	Further tightening angle	Recommended arm length of tool
φ1/4" (6.4)	60 to 90 degrees	Approx. 6" (150mm)
φ3/8" (9.5)	60 to 90 degrees	Approx. 8" (200mm)
φ1/2" (12.7)	30 to 60 degrees	Approx. 10" (250mm)
φ5/8" (15.9)	30 to 60 degrees	Approx. 12" (300mm)

**Flange Connection**

- a) The flange sheet surface should be clean and undamaged. (Clean any dirt away with a cloth and check that there has been no damage.)
- b) Coat the flange sheet surface with refrigeration oil (Ester or ether oil) and then insert the packing. (Do not use SUNISO oil.)

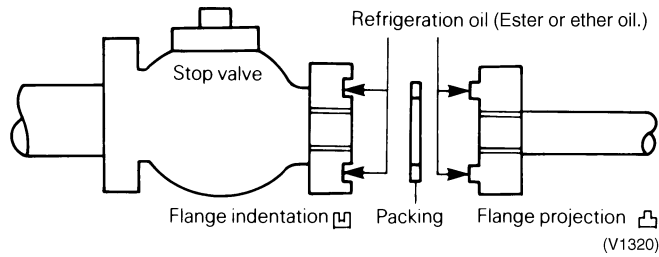

- c) Tighten the bolts in opposite corners first to ensure that the connection is true.

[Example]

Order: A→C→B→D

The bolts should be tightened little by little in the above order such that the same degree of torque is applied evenly to each corner.

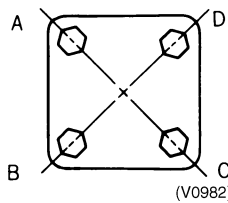

**Important points**

- 1. Only clean refrigeration/oil should be used to coat the flange. (i.e. free from dirt or water)
- 2. The correct amount of torque should be applied when tightening the flange bolts.

Standard torques for tightening screws and bolts

ISO hexagonal bolt

Size	Class	5.8(5T)			10.9(10T)		
		ft. lbf	kgf-cm ±15%	N-m ±15%	ft. lbf	kgf-cm ±15%	N-m ±15%
M8		9.0	125	1230	21.8	302	2960
M10		18.6	257	2520	44.9	620	6080
M12		31.6	436	4280	76.0	1,050	10,300
M16		74.6	1,030	10,100	179.7	2,480	24,300
M20		148.5	2,050	20,100	358.7	4,950	48,500

### 3.2.4 Thermal Insulation Work (Refrigerant Piping)

■ Operational steps

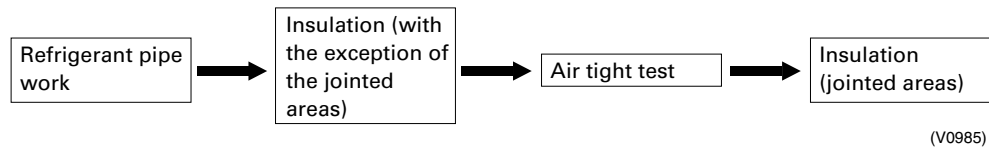

**Materials**

The thermal insulation materials which are used must be well able to withstand the heat from the pipes.

Example:

Heat pump type: Heat resistant polyethylene foam (heat resistance of at least 120°C)

Cooling only: Polyethylene foam (heat resistance of 100°C or more)

**Essential Points of Thermal Insulation**

The insulation of jointed areas such as the soldered, flared or flanged sections should only be carried out after the successful completion of the air tight test.

Attention should be paid to the unit model and its operating conditions since there are occasions when the gas and liquid pipes also need to be thermally insulated.

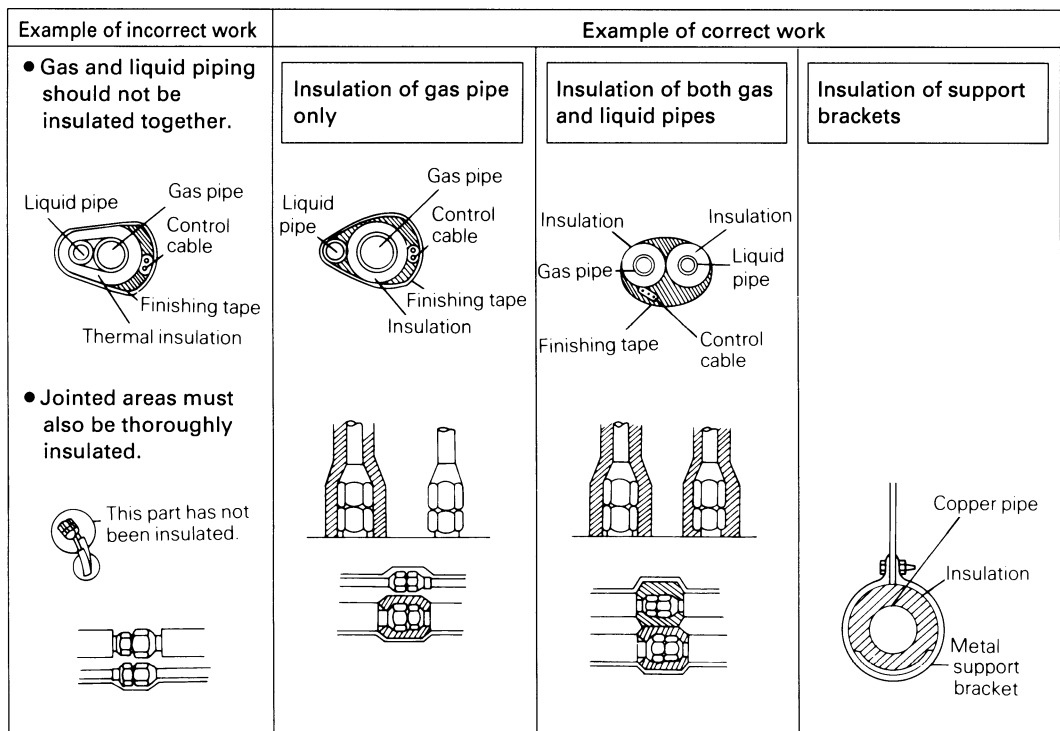

■ Important points

1. The thickness of the thermal insulation material must be determined in the light of the pipe sizes.

Pipe size in. (mm)	Thickness of insulation material
φ1/4~φ1 (6.4mm~25.4mm)	φ1/2 or more (12.5mm or more)

- It will be necessary to increase the values in the above table for top floors or where conditions are hot and humid. (Refer to Installation manual "6-5 Pipe insulation" for more detail)
- Where a customer supplies his own specifications then these must be adhered to.
- Where it is anticipated that the air conditioning unit will be operated at external air temperatures of 10°C or less then thermal insulation will also be required for the liquid pipes.

**Heat Recovery Series**

- Suction, Discharge Gas piping, liquid piping must be insulated.
- Example of thermal insulation work.

- 3 piping section (between outdoor unit and BS unit)

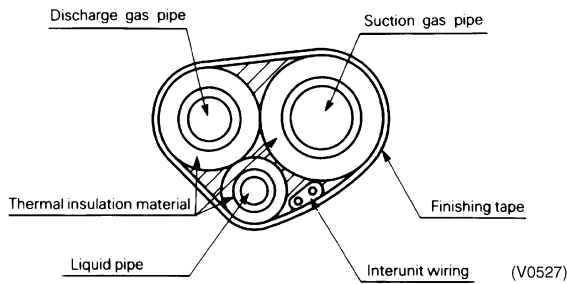

- 2 piping section (between BS unit and indoor unit)

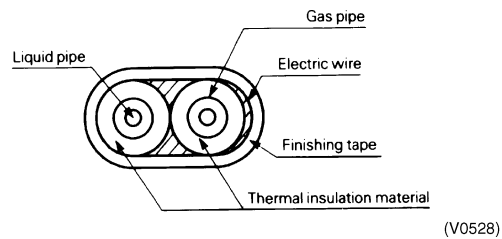

- If you think the humidity around the cooling piping might exceed 86°F and RH80%, reinforce the insulation on the cooling piping (at least 13/16" thick). Condensation might form on the surface of the insulation.

**3.2.5 Air Tight Test**

- **Operational steps**

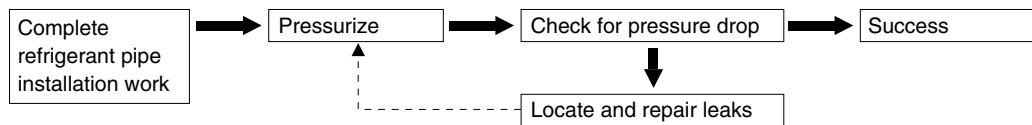

**Essential Points of Testing (Maintaining Pressure Over a Period)**

The key to successful testing is strict adherence to the following procedure:

- a) The liquid and gas piping in each refrigerant system should be pressurized in turn in accordance with the following steps. (Nitrogen gas must be used.)

- **Step 1: increase pressure to 13.05psi for 3 minutes or more** } Indicates existence of major leaks
- **Step 2: increase pressure to 217psi for 5 minutes or more** }
- **Step 3: increase pressure to 551psi for approx. 24 hours** } Indicates existence of minor leaks

\*Increasing the system pressure to 551psi does not guarantee the identification of minor leaks if pressure is maintained for only a short time. It is therefore recommended that the system remain pressurized in accordance with Step 3 above for at least 24 hours.



**Note:** The pressure must on no account be increased beyond 551psi.

**b) Check for pressure drop**

**If there is no drop in pressure then the test is deemed a success.**

If the pressure drops then the leak must be located. See following page.

However, if there is a change in the ambient temperature between the pressurizing stage and the time when you check for a drop in pressure then you will have to adjust your calculations accordingly since a change of 1°F can account for a pressure change of approximately 0.80psi.

**Compensating adjustment value:**

**(temperature at time of pressurizing – temperature at time of checking) × 0.80**

Example:

Time of pressurizing: 551psi 77°F

24 hours later: 543psi 68°F

The pressure drop in such a case is deemed to be zero (successful test).

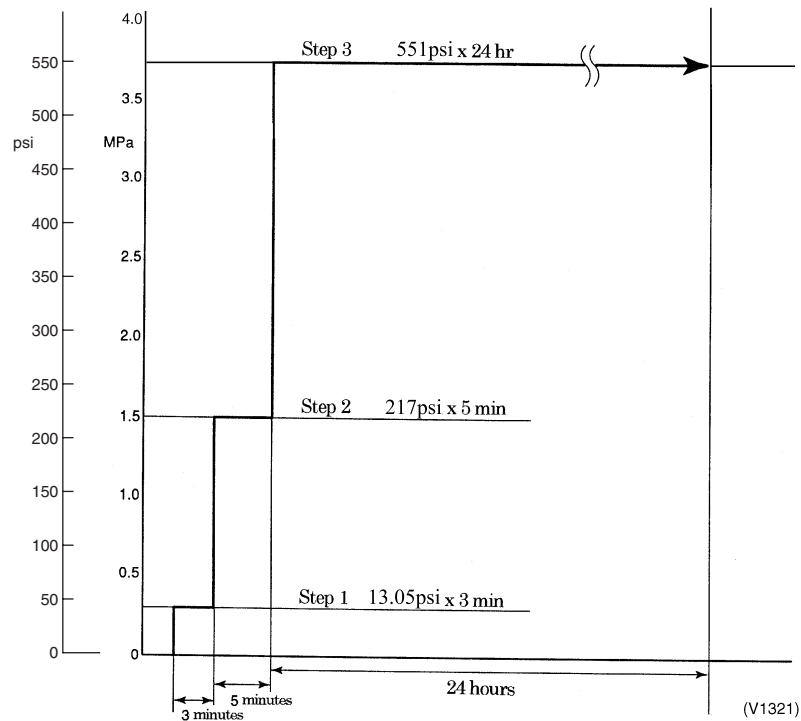

(V1321)

## Checking for Leaks

[Check 1] (Where pressure falls while carrying out Steps 1 to 3 described on previous page)

- Check by ear.....Listen for the sound of a major leak.
- Check by hand.....Check for leak by feeling around jointed sections with hand.
- Soap and water check (\*Snoop).....Bubbles will reveal the presence of a leak.

[Check 2] (When searching for a minor leak or when there has been a fall in pressure while the system has been fully pressurized but the source of the leak cannot be traced.)

1. Release the nitrogen until the pressure reaches 13.05psi.
2. Increase pressure to 217psi using gaseous flon gas (R410A). (Nitrogen and flon gas mixed)
3. Search for the source of the leak using a leak detector.
4. If the source of the leak still cannot be traced then repressurize with nitrogen up to 551psi and check again. (The pressure must not be increased to more than 551psi.)

### Setup of Air-tight Test

As for the air-tight test, the setup of devices shown in the following figure is recommended with considerations given to “vacuum drying and refrigerant additional charging”, which are operation steps following the air-tightness test.

In order to conduct the air-tight test, with stop valves of 8.Gas side, 10.liquid side and 15.Oil equalization piping and those of the refrigerant and vacuum pump all closed, then open the nitrogen gas stop valve, 7.Valve A, 8.Valve B and 17. Valve C while adjusting the nitrogen gas pressure regulating valve, thus increasing the pressure.

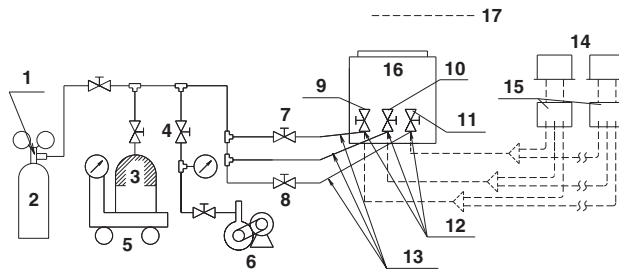

- 1. Pressure reducing valve
- 2. Nitrogen
- 3. Tank
- 4. Siphon system
- 5. Measuring instrument
- 6. Vacuum pump
- 7. Valve A
- 8. Valve B
- 9. Suction gas line
- 10. Liquid side
- 11. Discharge gas line
- 12. Shutoff valve service port
- 13. Charge hose
- 14. Indoor unit
- 15. BS unit
- 16. Outdoor unit
- 17. Dotted lines represent onsite piping

**■ Important points**

1. Where the lengths of piping involved are particularly long then the air tight test should be carried out block by block.

Example:

1. Indoor side
2. Indoor side + vertical pipes
3. Indoor side + vertical pipes + outdoor side

### 3.2.6 Vacuum Drying

**What is vacuum drying?**

Vacuum drying is:

"The use of a vacuum pump to vaporize (gasify) the moisture (liquid) inside the pipes and expel it leaving the pipes completely dry inside."

At 1 atm (760 mmHg) the boiling point (evaporating temperature) of water is 212°F (100°C) but if a vacuum is created inside the pipes using a vacuum pump then the boiling point is rapidly reduced as the degree of the vacuum is increased. If the boiling point is reduced to a level below that of the ambient temperature then the moisture in the pipes will evaporate.

<Example>  
When outside temperature is 44.9°F (7.2°C)  
As shown in the table on the right, the degree of vacuum must be lowered below -752mmHg.

→

Boiling point of water °F (°C)	Pressure			
	*mmHg	Pa	Torr	psi
104 (40)	-705	7333	55	-13.69
86 (30)	-724	4800	36	-14.0
80 (26.7)	-735	3333	25	-14.2
75.9 (24.4)	-738	3066	22	-14.28
71.9 (22.2)	-740	2666	20	-14.31
69.0 (20.6)	-742	2400	18	-14.35
64.0 (17.8)	-745	2000	15	-14.41
59.0 (15.0)	-747	1733	13	-14.45
53.0 (11.7)	-750	1333	10	-14.51
44.9 (7.2)	-752	1066	8	-14.55
32 (0)	-755	667	5	-14.61

Above figures (mmHg) are gauge pressure readings.



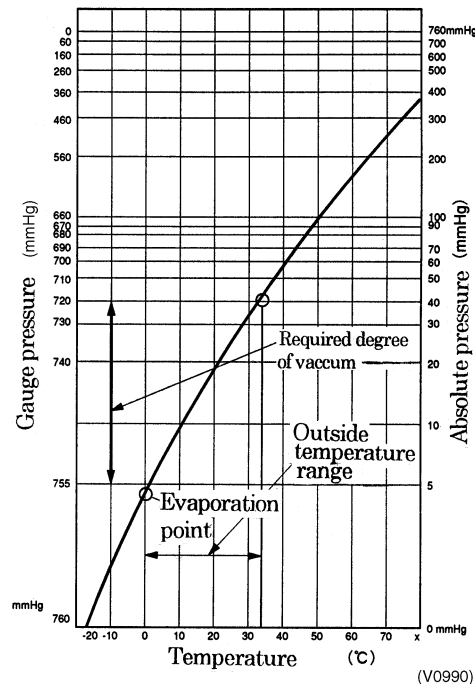

The evacuation of air conditioner piping provides the following effects.

1. Vacuum drying
  2. Removes air and nitrogen (used in air-tightness test) from the inside of pipes.
- Therefore, it is necessary to ensure that the both purposes have been achieved in the vacuum drying operation.

### Key points

**Lower the degree of vacuum to below -14.6psi (-755mmHg)**

(V1216)

## Choosing a Vacuum Pump

### General

Refrigerant piping content volume of the VRVII R410A Series is larger than the VRV Inverter Series, and consequently takes more time for vacuum drying. If you have time to spare, you may use the same vacuum pump, but if you want to save time, you will have to use a pump with higher exhaust velocity (exhaust volume).

### The Necessity for Counter Flow Prevention

After the vacuum process of the refrigerant cycle, the inside of the hose will be vacuumed after stopping the vacuum pump, and the vacuum pump oil may flow back. Moreover, if the vacuum pump stops during the operation by some reason, the same thing happens. In such cases, different oil mixes in the HFC system refrigerant apparatus cycle, and becomes the cause of a refrigerant circuit trouble. Therefore, in order to prevent the counter flow from the vacuum pump, a check valve is needed.

### Vacuum pump with check valve or vacuum pump adapter

Vacuum pump with check valve



Vacuum pump adapter  
(Reverse flow preventive)  
vacuum adapter



**1. Vacuum pump performance**

The 2 most import things for determining vacuum pump performance are as follows:

- (1) Exhaust velocity
- (2) Degree of vacuum

**(1) Exhaust velocity**

Exhaust volume is usually expressed as l/min or m<sup>3</sup>/h. The larger the number, the faster vacuum id achieved.

Generally speaking, the faster the exhaust velocity, the larger and heavier the vacuum pump itself is.

Commercially available vacuum pumps (exhaust velocity of 20 - 30 l/min) usually take an extremely long time to achieve vacuum. (We recommend a vacuum pump of approx. 60 - 100 l/min.)

**(2) Degree of vacuum**

Ultimate vacuum varies largely according to use of the vacuum pump. Vacuum pumps used for vacuum forming cannot be used for vacuum drying. (A vacuum pump with a high degree of vacuum is required.)

When selecting a vacuum, you should select one which is capable of achieving 0.2 Torr of ultimate vacuum.

Degree of vacuum is expressed in Torr, micron, mmHg, and Pascal (Pa). The units correlate as follows:

	Unit	Standard atmospheric pressure	Perfect vacuum
Gauge Pressure	kg/cm <sup>2</sup>	0	-1.033
Absolute Pressure	kg/cm <sup>2</sup> abs	1.033	0
Torr	Torr	760	0
Micron	Micron	760000	0
*mmHg	mmHg	0	760
Pa	hPa	1013.33	0
psi	psi	0	-14.7

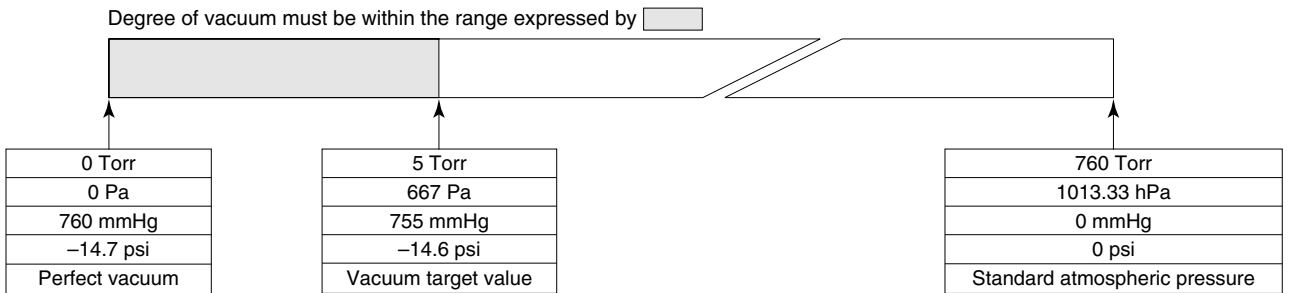

(V0992)

**2. Vacuum pump maintenance**

Because of their nature, most vacuum pumps contain large amounts of oil which lubricates bearings, etc., and functions to enhance airtightness of pistons. When using a vacuum pump to discharge air from refrigerant piping, moisture in the air tends to get mixed in with the oil. You must therefore change oil periodically and make sure the proper oil level is maintained. (Perform periodic inspections in accordance with the operating instructions.)

**3. Degree of vacuum measurement**

An extremely accurate vacuum gauge is required to test degree of vacuum. You cannot accurately measure degree of vacuum with the compound gauge on the gauge manifold. A Pirani vacuum gauge is required to measure degree of vacuum accurately. Because Pirani gauges are very sensitive and require extreme care when using, they are not very suitable for use in the field. You should therefore use the Pirani gauge to calibrate the attached vacuum gauge on the gauge manifold and the degree of vacuum of the vacuum pump.

**4. Calibration method**

1. Connect a Pirani vacuum gauge and the gauge manifold vacuum gauge (0 - 760 mmHg) to the vacuum pump at the same time, and run the pump for about 3 minutes.
2. Make sure the reading of the Pirani vacuum gauge is 5 Torr (667 Pa) or less. The reading of conventional vacuum pumps lowers to about 0.2 Torr.  
If the reading is not 5 Torr or less, check the vacuum pump oil. (Oil is low in many cases.)
3. Check the attached gauge on the gauge manifold. Adjust the gauge if the reading is not exactly correct.
4. Adjust the gauge manifold valve so that the Pirani vacuum gauge reads 5 Torr.
5. Mark the position indicated by the gauge manifold gauge with an oil based ink pen.
6. Use the mark of the gauge manifold as a target when vacuuming in the field.

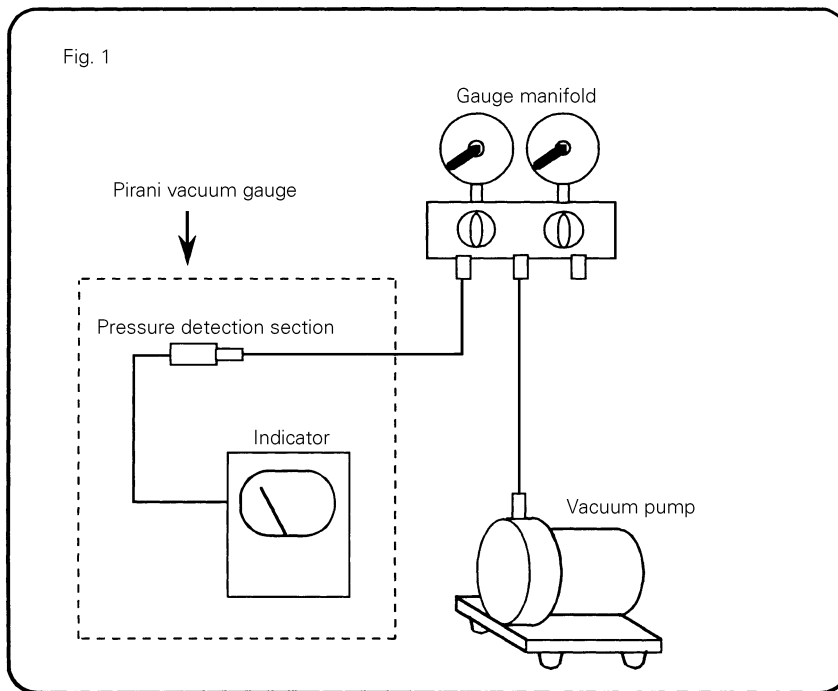

(V0993)

(Reference) Types of vacuum pump with respective maximum degree of vacuum

Type	Maximum Degree of Vacuum	Use	
	Expulsion Capacity	Vacuum Drying	Air Expulsion
Oil Rotary (Oil Using)	-14.66psi (0.02 mmHg) 100 l/min	Suitable	Suitable
Oilless Rotary (No Need of Oil)	-14.5psi (10 mmHg) 50 l/min	Unsuitable	Suitable
	-14.66psi (0.02 mmHg) 40 l/min	Suitable	Suitable

← Many handy pumps fall into this category

**Vacuum Drying Procedure**

There are two vacuum drying methods and the appropriate one should always be chosen to conform with individual local conditions.

[Normal vacuum drying].....The standard method

[Operational steps]

1. Vacuum drying (1st time): Connect a manifold gauge to the service port of the liquid or gas pipe and operate the vacuum pump for at least 2 hours.

**(The degree of vacuum produced should be in excess of -14.61psi (5 mmHg))**

If after 2 hours the vacuum produced has not exceeded 5 mmHg then either there is moisture in the pipe or there is a leak. Operate the vacuum pump for a further hour.

If, even after 3 hours, the vacuum has not reached -14.61 (5 mmHg) then check the system for a leak.

2. Carry out maintained vacuum test.

Produce a vacuum in excess of -14.61psi (-755 mmHg) and do not release it for an hour or more. Check the vacuum gauge to make sure that it has not risen. (If the gauge does rise then there is still moisture in the pipe or there is a leak somewhere.)

3. Additional charge of refrigerant.

Connect the charging cylinder to the liquid pipe service port and charge with the required amount of refrigerant.

4. Open stop valve to the full.

Open the stop valves on the liquid and the gas pipes to the full.



**Note:**

Vacuums should be produced in both the liquid and the gas pipes.

(Because there are a large number of functional components in the indoor unit which cut off the vacuum mid-way through)

[Standard vacuum drying time chart]

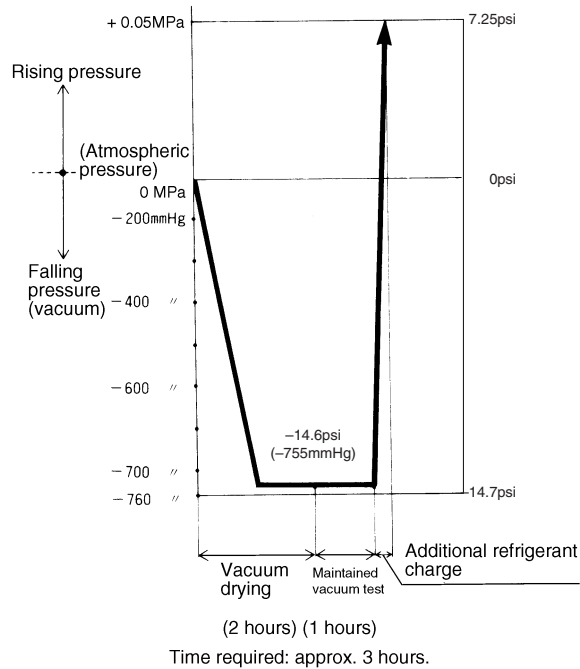

(V0991)

### Special vacuum drying

This vacuum drying method is selected when there is a suspicion that there may be moisture in the pipes.

For example:

- When moisture was discovered during the refrigerant pipe flushing operation
- When there is a risk of condensation forming inside the pipes during periods of heavy rainfall
- When there is a risk of condensation forming inside the pipes due to a long term of works
- When there is a risk that rainwater may have entered the pipes during installation

The special vacuum drying method is the same as the standard method except that nitrogen is introduced into the pipes to break the vacuum on one or more occasions during the course of the operation.

[Operational steps]

1. Vacuum drying (1st time): 2 hours
2. Vacuum breaking (1st time): Use nitrogen to raise pressure to +7.25psi (+0.05MPa).  
(Since the nitrogen gas used to break the vacuum is dry nitrogen this process serves only to enhance the overall drying effect of the vacuum drying operation itself.  
However, since the effectiveness of this process is severely impaired by a high moisture level inside the pipes, the utmost care is required during installation to see that water does not enter or form inside the refrigerant pipes.)
3. Vacuum drying (2nd time): Operate the vacuum pump for at least 1 hour.  
(Observations: Degree of vacuum has reached -14.61psi (5 mmHg). If the degree of vacuum has not reached -14.61psi (5 mmHg) after 2 hours or more then repeat the operations at 2 (vacuum breaking) and 3 (vacuum drying) above.)
4. Carry out maintained vacuum test: 1 hour
5. Additional charge of refrigerant
6. Open stop valve to the full

- \* The gas used for the vacuum breaking operation must be nitrogen.  
(The use of oxygen brings a serious risk of explosions)

[Special vacuum drying time chart]

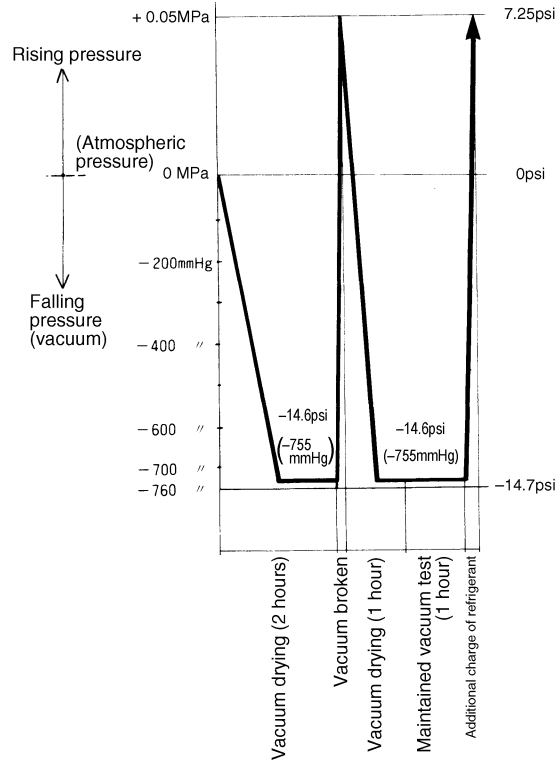

Time required: approx. 4 hours

(V0994)

### 3.2.7 Additional Charge of Refrigerant at installation time

#### ■ Operational steps

Use the length of the piping to calculate the amount of refrigerant required



Additional charge of refrigerant

(V0995)

#### Important points

1. The results of all calculations must be recorded. (Make a list.)
2. The refrigerant will need to be additionally charged whenever the distance between the outdoor unit and the most distant indoor unit is more than 10m.
3. The additional charging operation should be carried out by input of liquid from Service port at liquid stop valve following completion of the vacuum drying operation.
4. When the additional charging operation cannot be satisfactorily completed use the action of the compressor to complete the additional charging during the test run.

#### Refrigerant Charging Instructions

HFC401A are Quasi-azeotropic\* refrigerants. Therefore, these refrigerants must be charged in the liquid state. When charging the refrigerant into equipment from the refrigerant cylinder, turn the refrigerant cylinder upside down.

Important: Make sure that the refrigerant (liquid) is taken out from the bottom part of the refrigerant cylinder. Do not take out the refrigerant (gas) at the upper part of the refrigerant cylinder for charging.

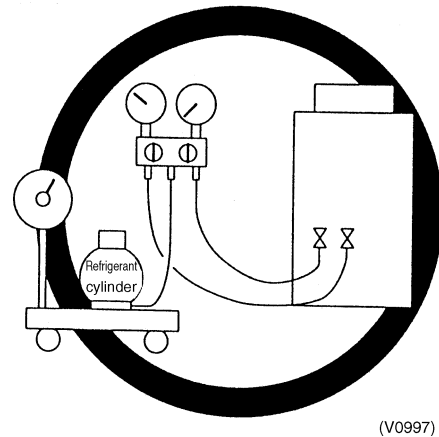
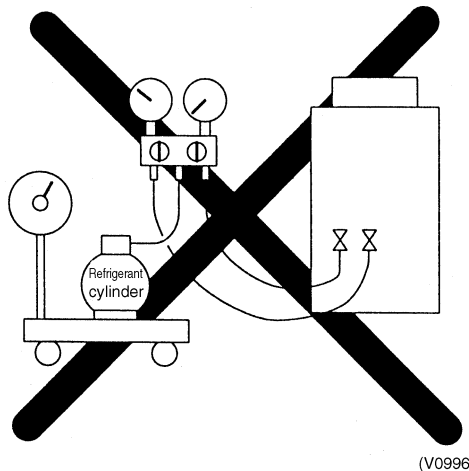

#### Caution

Since some refrigerant cylinders differ in the internal mechanism, it is necessary to examine the cylinder carefully. (Some cylinders have a siphon tube to eliminate the need for turning it upside down.)

## Siphon tube

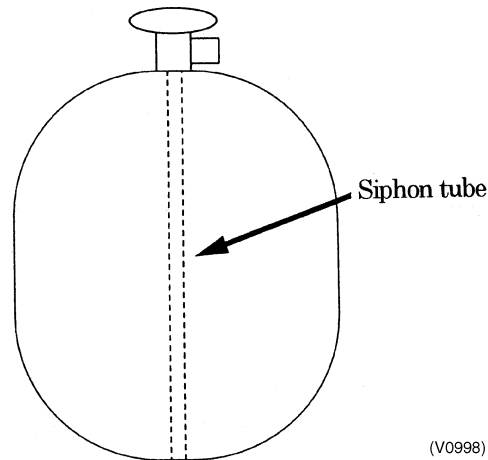

## &lt;\*Non-azeotropic refrigerants or Quasi-azeotropic refrigerants&gt;

When a refrigerant is a mixture of two or more types with different evaporation temperature, it is called a non-azeotropic refrigerant. If all refrigerant components evaporate at the same temperature, the mixture is called an azeotropic refrigerant.

If a non-azeotropic refrigerant is charged into equipment in the gaseous state, the refrigerant components that evaporate sooner than others enter the equipment, and the refrigerant that evaporate after others remain in the refrigerant cylinder.

\*Quasi-azeotropic mixture refrigerant: mixture of two or more refrigerants having similar boiling points.

## Caution items

The following devices designed for R-22 cannot be used to charge the new refrigerants. Be sure to use the devices specifically designed for the new refrigerants.

1. Charging cylinder...(Pressure resisting specification is different.)
2. Gauge manifold (including hose)...(same as above)



### 3.2.8 Drain Pipe Work (Indoor)

■ Operational steps

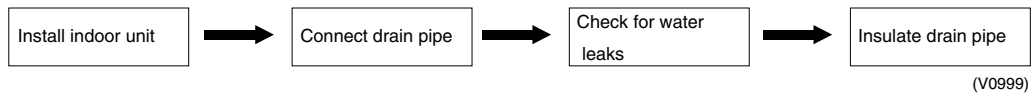

#### Drain Pipe Gradient and Support

- a) The drain pipe must be fitted at a gradient of at least 1/100. The drain pipe should be as short as possible and free from airlocks.

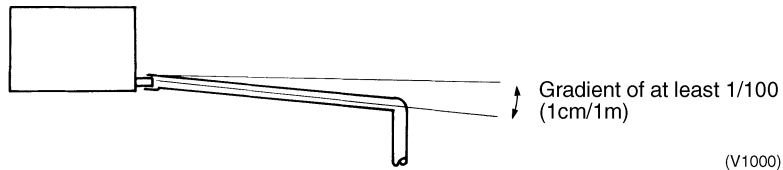

- b) Suspension bolts should be used to support long stretches of drain pipe in order to ensure that a gradient of 1/100 is maintained. (PVC pipes should not be bent)

Spacing of supports for horizontal piping

Class	Nominal diameter	Spacing
Rigid PVC pipe	1"~1 1/2" (25~40mm)	3.28~4.92 ft (1~1.5m)

- c) The length of pipe laid horizontally should be kept to a minimum.

#### Drain Trap

Fit any indoor unit whose drain pipe connection is subjected to negative pressure, with a drain trap. (FXMQ30~48M only)

- a) Rig the drain trap as shown in the drawing below.

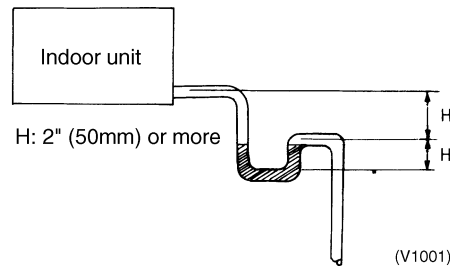

- b) Provide one trap per unit. A single trap for converging units will prove ineffective.

- c) Rig the trap to allow for future cleaning.

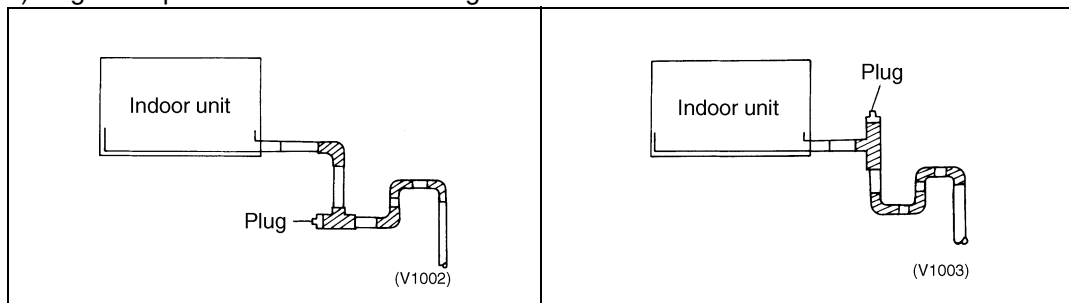

## Grouped Drain Piping

1. It is standard work practice to make connections to the main pipe from above. The pipe down from the combination should be as large as possible.

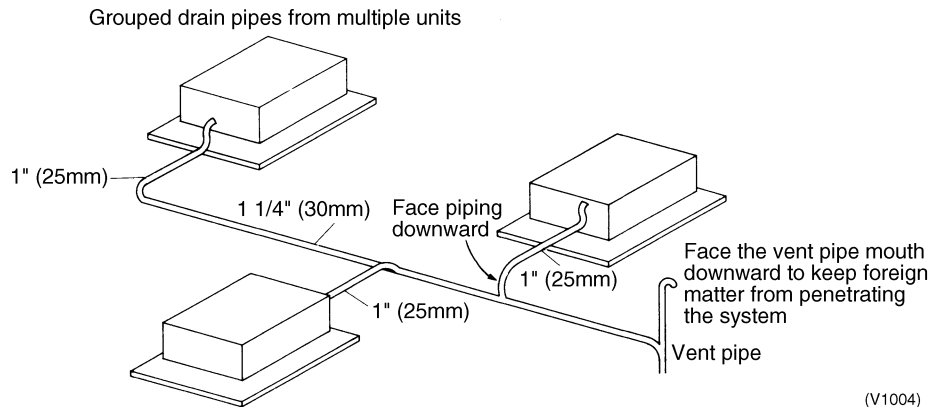

2. The pipework should be kept as short as possible and the number of indoor units per group kept to a minimum.

## Use of an Auxiliary Drain Hose (Flexible)

If a drain pan made of polystyrene foam is used then an auxiliary drain hose (flexible) is also essential. A flexible drain hose permits the drain socket and drain pipe to be connected without difficulty and prevents any undue strain being placed on the drain pan.

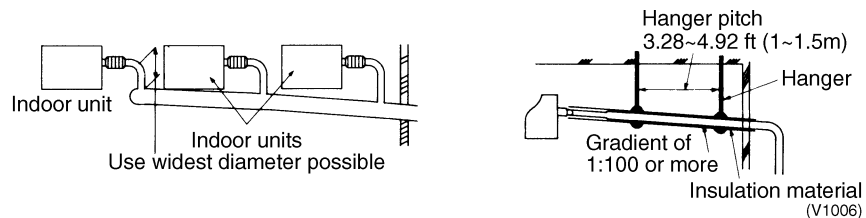
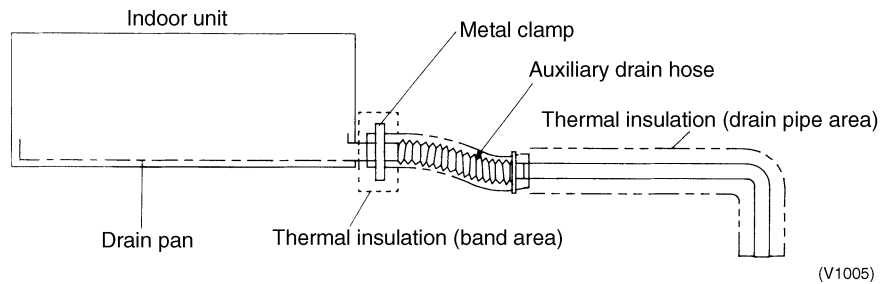

### Important points

1. The drain pipe should be at least equal in size to that of the indoor unit.
2. The drain pipe is thermally insulated to prevent the formation of condensation inside the pipe.
3. The drain up mechanism should be fitted before the indoor unit is installed and when the electricity has been connected some water should be added to the drain pan and the drain pump checked to see that it is functioning correctly.
4. All connections should be secure. (Special care is needed with PVC pipe)  
The use of a colored adhesive with PVC pipes will help you to remember to connect them up.)

## Piping Diameter for Grouped Drain Pipes

- Select piping diameter from the below table in accordance with the amount of condensation drained by all units with a common drain pipe.
- Consider 2 l/hr of drainage for every 1 HP. For example, drainage from 3 units running at 2 HP and 2 units running at 3 HP is calculated as follows.  
 $2 \text{ (l/hr)} \times 2 \text{ (HP)} \times 3 \text{ (units)} + \{ 2 \text{ (l/hr)} \times 3 \text{ (HP)} \times 2 \text{ (units)} = 24 \text{ l/hr}$

1. Relationship between horizontal pipe diameter and allowable drainage (for extended ventilation system)

JIS nominal	Vinyl chloride pipe diameter in. (mm)	Allowable flow rate (l/hr)		Remarks
		Piping gradient 1:50	Piping gradient 1:100	
VP20	3/4" (20)	39	27	(Reference value) Cannot be used in grouped piping.
VP25	1" (25)	70	50	
VP30	1 1/4" (31)	125	88	Can be used in grouped piping.
VP40	1 1/2" (40)	247	175	
VP50	2" (51)	473	334	



### Note:

- Calculations have been made with water area inside the pipe as 10%.
- Allowable flow rate figures below the decimal have been discarded.
- Use VP30 or larger pipe after the convergence point.

2. Relationship between riser diameter and allowable drainage (for extended ventilation system)

JIS nominal	Vinyl chloride pipe diameter in. (mm)	Allowable flow rate (l/hr)	Remarks
VP20	3/4" (20)	220	(Reference value) Cannot be used in grouped piping.
VP25	1" (25)	410	
VP30	1 1/4" (31)	730	Can be used in grouped piping.
VP40	1 1/2" (40)	1440	
VP50	2" (51)	2760	
VP65	2 1/2" (67)	5710	
VP75	3" (77)	8280	



### Note:

- Allowed flow rate figures below the decimal have been discarded.
- Use VP30 or larger pipe in risers.
- Use the same drain pipe for the humidifier as the indoor unit.

### 3.2.9 Drain Piping for Each Model

#### Ceiling Mounted Cassette Type (FXFQ-M Multi-flow)

##### 1. Rig drain piping

- Lay pipes so as to ensure that drainage can occur with no problems.
- Employ a pipe with either the same diameter or with the diameter larger (excluding the raising section) than that of the connecting pipe (PVC pipe, nominal diameter 25 mm, outside diameter 32 mm).
- Keep the drain pipe short and sloping downwards at a gradient of at least 1/100 to prevent air pockets from forming.
- If the drain hose cannot be sufficiently set on a slope, execute the drain raising piping.
- To keep the drain hose from sagging, space hanging wires every 40 to 60 inches.

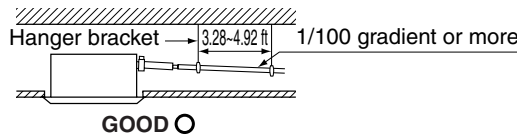

Fig. 18

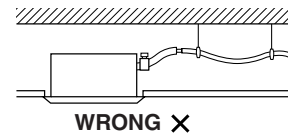

Fig. 19

- Use the attached drain hose (1) and clamp (2).
- Insert the drain hose into the drain socket up to the base, and tighten the clamp securely within the portion of a white tape of the hose-inserted tip. Tighten the clamp until the screw head is less than 3/16" from the hose.
- Wrap the attached sealing pad (10) over the clamp and drain hose to insulate.
- Make sure that heat insulation work is executed on the following 2 spots to prevent any possible water leakage due to dew condensation.
  - Indoor drain pipe
  - Drain socket

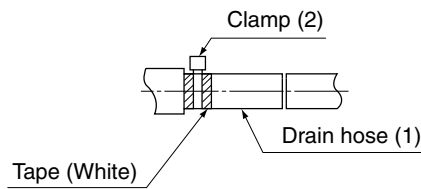

Fig. 20

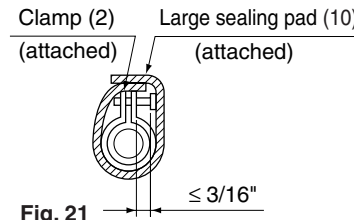

Fig. 21

#### <PRECAUTIONS FOR DRAIN RAISING PIPING>

- Install the drain raising pipes at a height of less than 21 5/8".
- Install the drain raising pipes at a right angle to the indoor unit and no more than 11 13/16" from the unit.

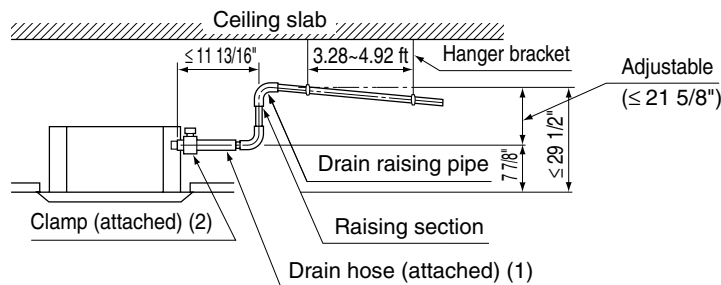

Fig. 22



#### Note:

- To ensure no excessive pressure is applied to the included drain hose (1), do not bend or twist when installing. (This may cause leakage.)
- If converging multiple drain pipes, install according to the procedure shown below.

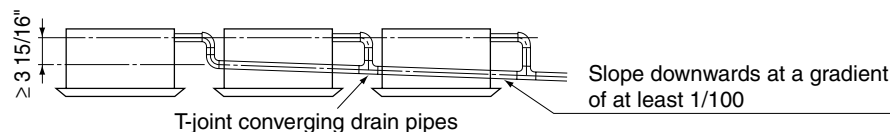

Fig. 23

Select converging drain pipes whose gauge is suitable for the operating capacity of the unit.





- 2 After piping work is finished, check if drainage flows smoothly.
- Add approximately 67oz (2000 cc) of water slowly from the air outlet and check drainage flow.

#### WHEN ELECTRIC WIRING WORK IS FINISHED

- Check drainage flow during COOL running, explained under “TEST OPERATION”.

#### WHEN ELECTRIC WIRING WORK IS NOT FINISHED

- Remove the terminal box lid connect a power supply and remote controller to the terminals.  
(Refer to the Installation Manual)

Next, press the inspection/test operation button “” on the remote controller. The unit will engage the test operation mode. Press the operation mode selector button “” until selecting FAN OPERATION “”. Then, press the ON/OFF button “”. The indoor unit fan and drain pump will start up. Check that the water has drained from the unit. Press “” to go back to the first mode.

- **Note that the fan also starts rotating.**
- Attach the terminal box lid as before.

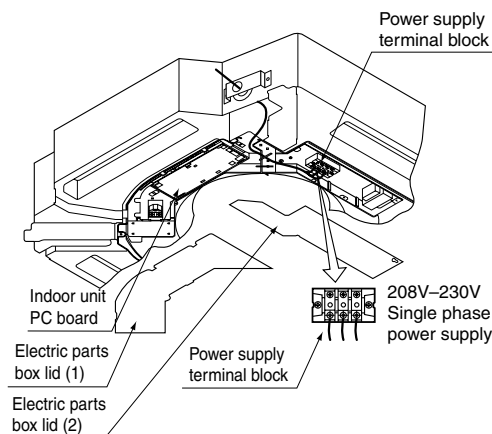
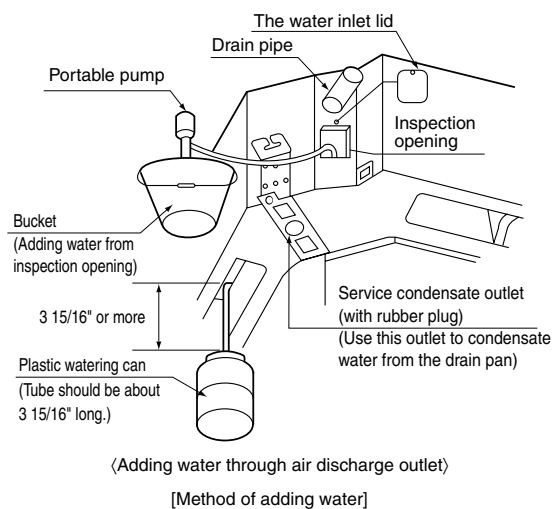

**Caution:** Drain piping connections  
Do not connect the drain piping directly to sewage pipes that smell of ammonia. The ammonia in the sewage might enter the indoor unit through the drain pipes and corrode the heat exchanger.

**Ceiling Mounted  
Built-in Type  
(FXSQ-M)**

**Drain Piping**

Rig the drain pipe as shown below and take measures against condensation. Improperly rigged piping could lead to leaks and eventually wet furniture and belongings.

**(1) Rig drain piping**

- The diameter of the drain pipe should be greater than or equal to the diameter of the connecting pipe (vinyl tube; pipe size: 1" ; outer dimension: 1 1/4").
- Keep the drain pipe short and sloping downwards at a gradient of at least 1/100 to prevent air pockets from forming.
- If the drain hose cannot be sufficiently set on a slope, execute the drain raising piping.
- To keep the drain hose from sagging, space hanging wires every 40 to 60".

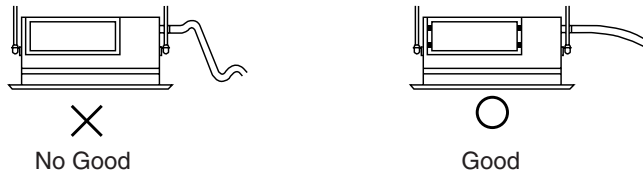

**Caution**

Setting the unit at an angle opposite to the drain piping might cause leaks.

- Use the attached drain hose and clamp metal. Tighten the clamp firmly. Insert the drain hose into the drain socket, up to the white tape. Tighten the clamp until the screw head is less than 3/16" from the hose.
- Wrap the attached sealing pad over the clamp and drain hose to insulate.
- Insulate the drain hose inside the building.

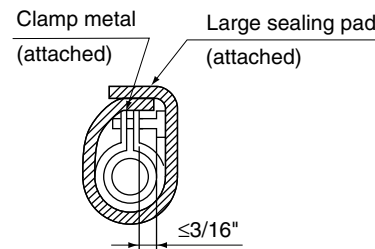
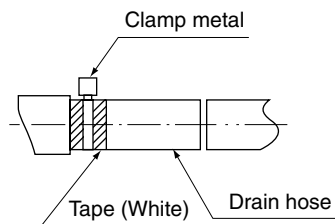

**< PRECAUTIONS FOR DRAIN RAISING PIPING >**

**< HOW TO INSTALL PIPING >**

- (1) Connect the drain hose to the drain raising pipes, and insulate them.
- (2) Connect the drain hose to the drain outlet on the indoor unit, and tighten it with the clamp.
- (3) Insulate both metal clamp and drain hose with the attached sealing pad.

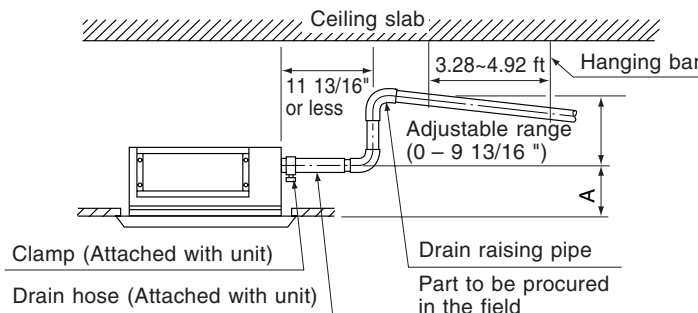

	A
When canvas duct is installed	13 3/4~20 7/8"
When air inlet panel is directly installed	10 13/16"

- If converging multiple drain pipes, install according to the procedure shown below.

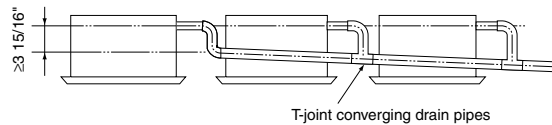

T-joint converging drain pipes

3P086156-3A-9

Select converging drain pipes whose gauge is suitable for the operating capacity of the unit.

**(2) After piping work is finished, check drainage flows smoothly.**

- Open the water inlet lid, add approximately 34 oz. (1000 cc) of water gradually and check drainage flow.

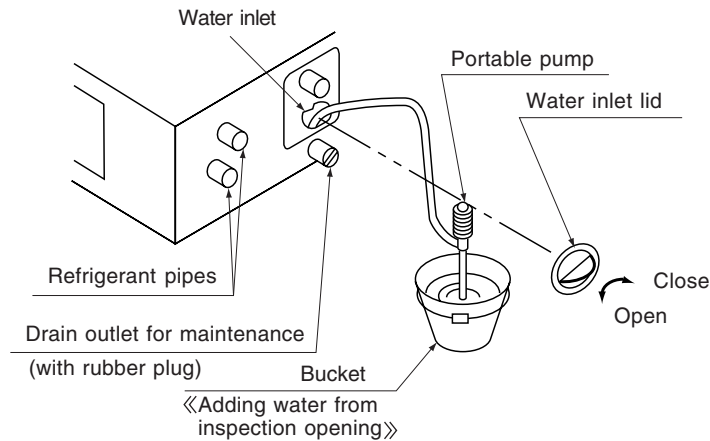

Note: Use this outlet to drain water from the drain pan.





**[ WHEN ELECTRIC WIRING WORK IS FINISHED ]**

- Check drainage flow during COOL running, explained under “TEST OPERATION.”

**[ WHEN ELECTRIC WIRING WORK IS NOT FINISHED ]**

Remove the electric parts box lid, connect a power supply and remote controller to the terminals.  
(Refer to the “Installation Manuals”)

Next, press the inspection/test operation button “” on the remote controller. The unit will engage the test operation mode.

Press the operation mode selector button “” until selecting FAN OPERATION “”. Then, press the ON/OFF button “”. The indoor unit fan and drain pump will start up. Check that the water has drained from the unit. Press “” to go back to the first mode.

You can check whether drainage is satisfactory or not by removing the access opening lid and checking the water level of the drain pan through the access opening.

**Be careful when doing so because the fan is turning at the same time.**

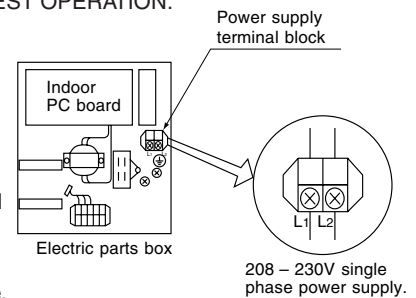

3P086156-3A-10

**Ceiling Mounted  
Duct Type  
(FXMQ-M)**

**<<Rig the drain pipe as shown below and take measures against condensation. Improperly rigged piping could lead to leaks and eventually wet furniture and belongings.>>**

**<<Insulate the drain hose inside the buildings>>**

(1) Install the drain pipes.

**FXMQ30-48M**

- Keep piping as short as possible and slope it downwards so that air may not remain trapped inside the pipe.
- Keep pipe size equal to or greater than that of the connecting pipe (Vinyl pipe of 1" nominal diam. and 1 1/4" outer diam.).
- Use the attached drain hose and clamp.  
Tighten the clamp firmly.
- Insulate the clamp metal with the attached sealing pad.
- **There is negative pressure inside the unit relative to atmospheric pressure when the unit is running, so be sure to provide drain trap on the drain outlet. (See the figure)**
- **In order to prevent foreign matter from building up inside the piping, you should avoid curves as much as possible, and arrange so the trap can be cleaned.**

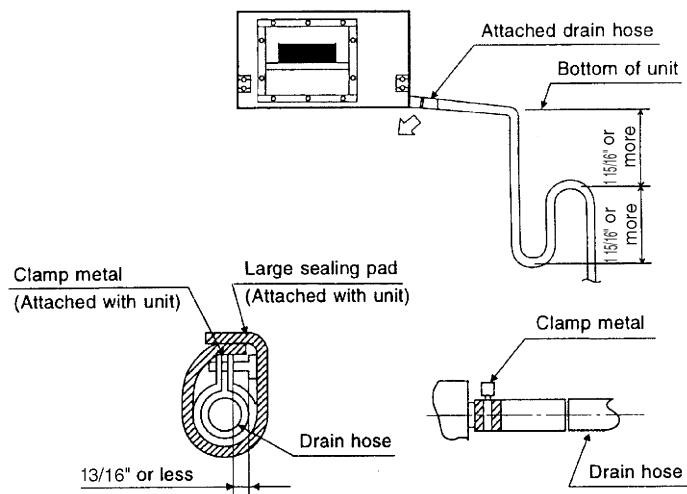

**Note:** If installing central drain piping, install according to the following right figure. (Install a drain trap for each indoor unit.)



- After piping work is finished, check drainage flows smoothly.



## Wall Mounted Type (FXAQ-M)

### (1) Install the drain piping. (Refer to Fig. 16)

- The drain pipe should be short with a downward slope and should prevent air pockets from forming.
- Watch out for the points in the figure 16 when performing drain work.

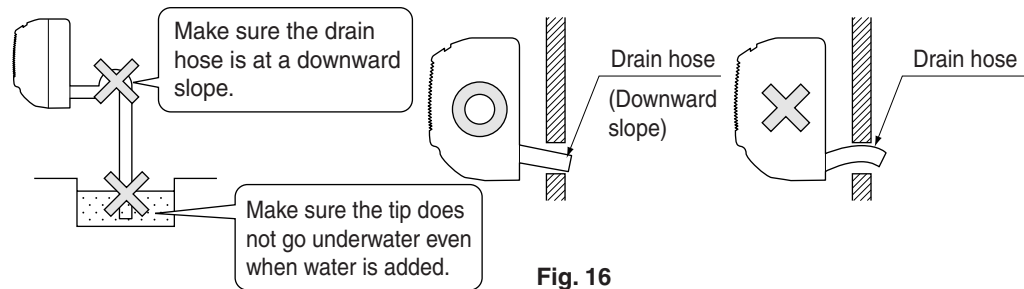

Fig. 16

- When extending the drain hose, use a commercially available drain extension hose, and be sure to insulate the extended section of the drain hose which is indoors. (Refer to Fig. 17)

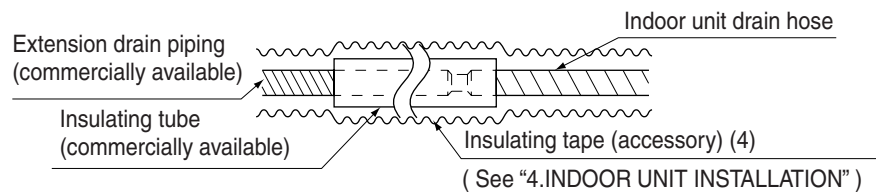
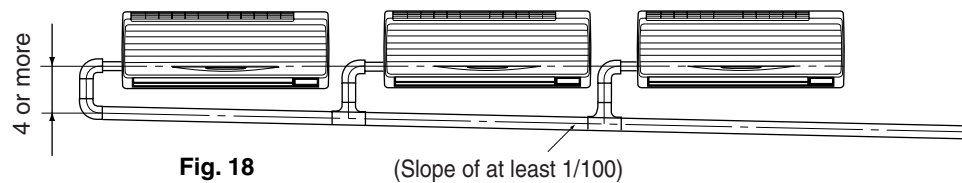

Fig. 17

- Make sure the diameter of the extension drain piping is the same as the indoor unit drain hose (hard vinyl chloride, I.D. 9/16") or bigger.
- In case of converging multiple drain pipes, install them referring to Fig. 18.
- Select diameter of drain piping which adapts to the capacity of the unit connected.



### (2) Make sure the drain works properly.

- After drain work is complete, perform a drain check by opening the front panel, **removing the air filter**, pouring water into the drain pan, and making sure water flows smoothly out of the drain hose. (Refer to Fig. 19)

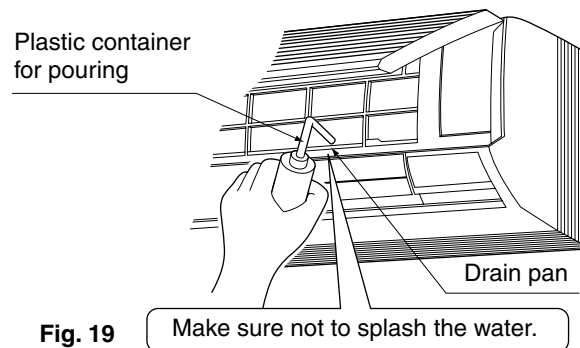

### Caution

Drain piping connections

Do not connect the drain piping directly to sewage pipes that smell of ammonia. The ammonia in the sewage might enter the indoor unit through the drain pipes and corrode the heat exchanger. Keep in mind that it will become the cause of getting drain pipe blocked if water collects on drain pipe.

**Floor Standing Type (FXLQ-M)**  
**Concealed Floor Standing Type (FXNQ-M)**

**Rig the drain pipe as shown below and take measures against condensate. Improperly rigged piping could lead to leaks and eventually wet furniture and belongings.**

(1) Carry out the drain piping

Connect the drain hose (1) using the attached hose and parts, as shown in the right drawing.

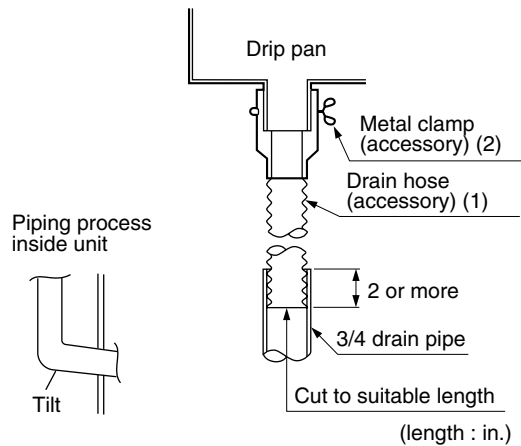

■ If converging multiple drain pipes, install according to the procedure shown below.

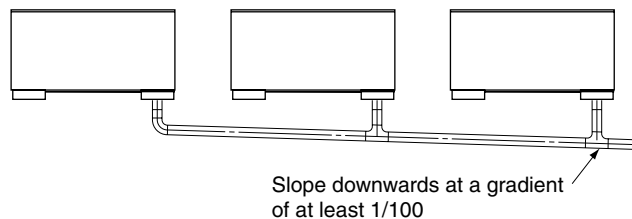

Select converging drain pipes whose gauge is suitable for the operating capacity of the unit.

(2) After piping work is finished, check drainage flows smoothly.

■ Add approximately 1 liter of water slowly from the air outlet and check drainage flow.

(3) Be sure to insulate all indoor pipes



**Caution**

- Drain piping connections Do not connect the drain piping directly to sewage pipes that smell of ammonia. The ammonia in the sewage might enter the indoor unit through the drain pipes and corrode the heat exchanger.
- Keep in mind that it will become the cause of getting drain pipe blocked if water collects on drain pipe.

## 3.2.10 Electrical Work

### Control Wiring

#### 1. Compatible types of wire

##### Wiring Specifications

Wiring Type	Sheathed Wire (2 wire)
Size	AWG18-16 (0.75~1.25 mm <sup>2</sup> )



#### Note:

1. Sheathed wire may be used for transmission wirings, but they do not comply with EMI (Electromagnetic Interference) (EN55014). When using sheathed wire, EMI must conform to Japanese standards stipulated in the Electric Appliance Regulatory Act. (If using a sheathed wire, the grounding shown in the figure on the left is unnecessary.)

#### 2. Problems arising from the use of unsuitable cable

##### a) When cable less than 0.75 mm<sup>2</sup> is used

Where the control wiring is particularly long the transmission signals may, for example, become unstable and the terminal relay cease to function. (Reduced voltage) The control system may become unduly subject to noise interference.

##### b) When cable more than 1.25 mm<sup>2</sup> is used

When wiring indoor units together, the terminal block will not be able to accommodate 2 cables simultaneously if the cables are larger than 1.25 mm<sup>2</sup>.

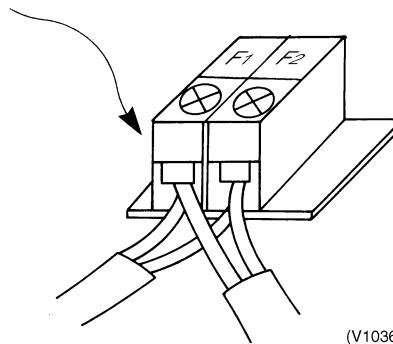

(V1036)

##### c) For multi-core cable

The greater play between wires, the more the transmitted wave is distorted and transmission destabilized.

- d) In the case of a remote controller with a three way selector for cooling, heating and ventilation, twin core cable should be used when the ventilation mode is not required and three core cable should be used when three way selection is required.

- e) Since there is a considerable risk of mixing high (220 to 240V) and low voltage in the case of, for example, a PCB for remote control, multiple core cable must not be used. (Internal wiring regulations and dielectric strengths of cables are relevant here.)

[Example of incorrect method]

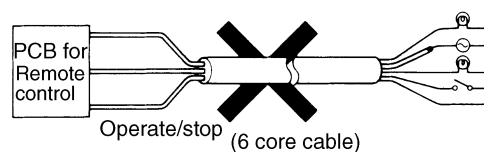

[Example of correct method]

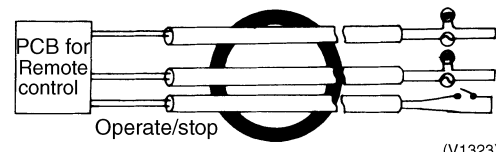

(V1323)

##### f) Other important points

1. The refrigerant circuit and the indoor/outdoor connecting cables must correspond exactly.
2. A suitable gap must be left between the control cables and the power supply cables where these are laid alongside each other. (See "Separation of control and power supply cables" on page 55)

## Power Supply (Cabling of Main Power Supply)

### 1. Choosing a circuit breaker

The power supply work must conform to local regulations. In Japan, the relevant regulations are the MITI ordinance determining technical standards for electrical equipment, and the Internal Wiring Provisions.

#### a) The indoor unit circuit breakers

- In accordance with the provisions for internal wiring (JEAC8001-1986), power may be supplied by means of crossover lines between the indoor units in a single system branch circuit.

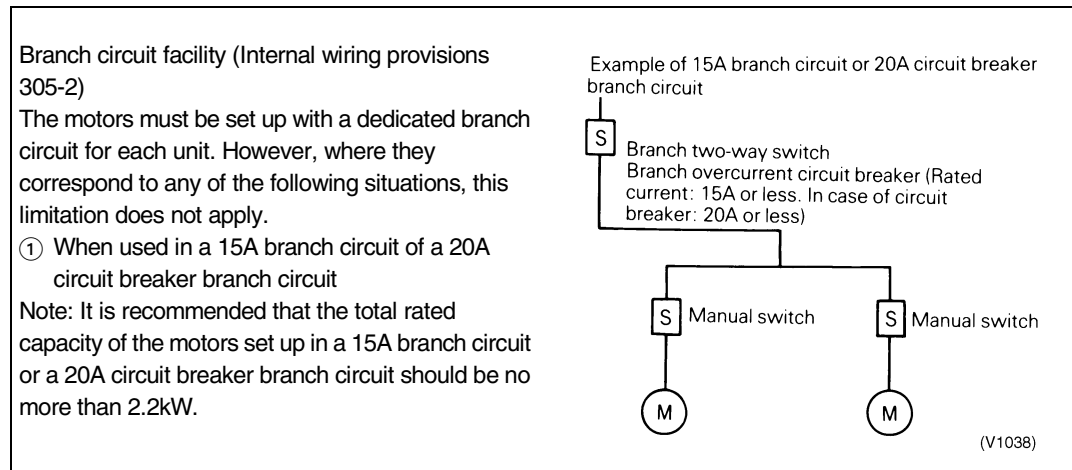

When using high static pressure indoor units the fan motors must have a large capacity. Single phase 220~240V branch circuits are therefore required for each indoor unit.

Example: Up to 10 × 2.5HP indoor units or 5 × 5HP indoor units can be wired together.

#### b) The outdoor unit circuit breaker

- A separate circuit breaker must be fitted for each unit.
- The motors incorporated into air conditioning system compressors are treated as special motors under the internal wiring provisions. The values which apply to normal motors are thus somewhat variance with those which apply to such compressor motors. You are recommended to adhere strictly to the procedures laid down in the technical materials included in, for example, the system design manuals.

Calculation of load (Refer to local regulation.)

With respect to the calculation of load for motors with special applications such as elevator, air conditioner and refrigerator motors, not only must the rated current be shown on the name plate of the said motor or piece of apparatus but it must also included all special characteristics or applications.



**Note:** The rated current for package air conditioners which use special purpose built-in compressor motors in their compressors in 1.2 times the operating current shown on the name plate.

## 2. Cable size

The thickness of the cables in the circuits (branch circuits) providing the main power supply to each item of apparatus must satisfy the following conditions:

1. To have a current tolerance of 40% or more of the rated current of the overcurrent circuit breaker (wiring circuit breaker, etc.).
2. To have a current tolerance of 125% or more of the rated current in cases where the rated current of the apparatus is 50A or less.
3. To have a current tolerance of 110% or more of the rated current in cases where the rated current of the apparatus is more than 50A.
4. To satisfy voltage drop standards.

## 3. Separation of control and power supply cables

- **If control and power cables are run alongside each other** then there is a strong likelihood of operational faults developing due to interference in the signal wiring caused by electrostatic and electromagnetic coupling.

The table below indicates our recommendations as to the appropriate spacing of control and power cables **where these are to be run side by side**.

Current capacity of power cable		Spacing (d)
100V or more	10A or less	12" (300mm)
	50A	20" (500mm)
	100A	40" (1000mm)
	100A or more	60" (1500mm)



### Note:

1. The figures are based on an assumed length of parallel cabling up to 33' (100m). For lengths in excess of 33' (100m) the figures will have to be recalculated in direct proportion to the additional length of cable involved.
2. If the power supply waveform continues to exhibit some distortion the recommended spacing in the table should be increased.

If the cables are laid inside conduits then the following points must also be taken into account when grouping various cables together for introduction into the conduits.

1. Power cables (including power supply to the air conditioner) and signal cables must not be laid inside the same conduit. (Power cables and signal cables must each have their own individual conduits.)
2. In the same way, when grouping the cables, power and signal cables should not be bunched together.

## ■ Important points

1. Earthing

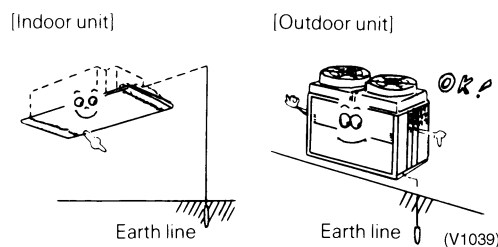

- Have the indoor and outdoor units both been earthed?

\* If the apparatus is not properly earthed then there is always a risk of electric shocks. The earthing of the apparatus must be carried out by a qualified person.

### 3.2.11 Duct Work (Indoor)

■ Operational steps

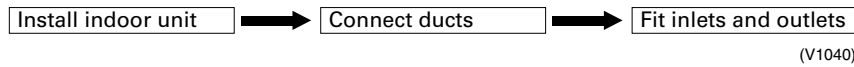

**Taking Account of Noise and Vibration**

a) Canvas joints must be used between the main unit and the air suction and discharge ducts. These fittings are designed to inhibit secondary noise resulting from the transmission of vibrations and operating noise from the main unit to the ducts or to the rest of the building.

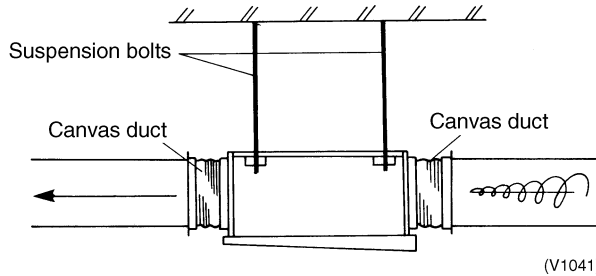

b) The speed of the airflow should be taken into account when choosing air suction and distribution grills in order to keep wind noise to minimum.

■ Important points

1. The air discharge duct must be thermally insulated.
2. The canvas duct on the inlet side must be set in a metal framework.
3. The air suction and distribution grills should be positioned to take into account the possibility of short circuits.
4. Static pressure should be checked to ensure that the airflow is within the specified range.
5. The air filter must be easily detachable.

### 3.2.12 Selection of Location

This unit, both indoor and outdoor, is suitable for installation in a commercial and light industrial environment. If installed as a household appliance it could cause electromagnetic interference. The VRV OUTDOOR units should be installed in a location that meets the following requirements:

1. The foundation is strong enough to support the weight of the unit and the floor is flat to prevent vibration and noise generation.
2. The space around the unit is adequate for servicing and the minimum space for air inlet and air outlet is available.

(refer to figure 1 and choose one of both possibilities)

< If installed as a single unit >

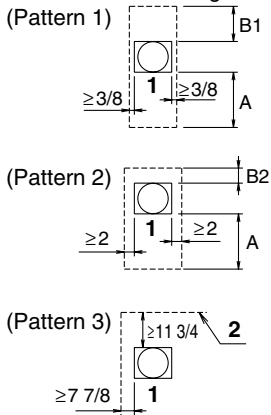

< When installed in serial >

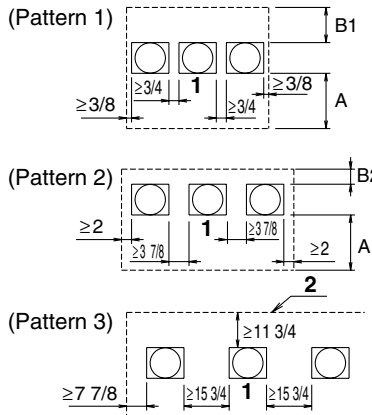

- $H1 \leq 59 \Rightarrow A \geq 19 \frac{5}{8}$
- $H1 = 59 + X \Rightarrow A \geq 19 \frac{5}{8} + X/2$
- $H2 \leq 19 \frac{5}{8} \Rightarrow B1 \geq 11 \frac{3}{4}$
- $\Rightarrow B2 \geq 3 \frac{7}{8}$
- $H2 = 19 \frac{5}{8} + Y \Rightarrow B1 \geq 11 \frac{3}{4} + Y/2$
- $\Rightarrow B2 \geq 3 \frac{7}{8} + Y/2$

1. Front side
2. No limit to wall height
3. Suction side

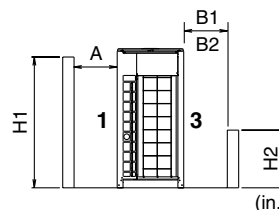

3. There is no danger of fire due to leakage of inflammable gas.
4. Ensure that water cannot cause any damage to the location in case it drips out the unit (e.g. in case of a blocked drain pipe).
5. The piping length between the outdoor unit and the indoor unit may not exceed the allowable piping length. (see "Example of connection")
6. Select the location of the unit in such a way that neither the discharged air nor the sound generated by the unit disturb anyone.
7. Make sure that the air inlet and outlet of the unit are not positioned towards the main wind direction. Frontal wind will disturb the operation of the unit. If necessary, use a windscreen to block the wind.

**Caution**

1. An inverter air conditioner may cause electronic noise generated from AM broadcasting. Examine where to install the main air conditioner and electric wires, keeping proper distances away from stereo equipment, personal computers, etc.

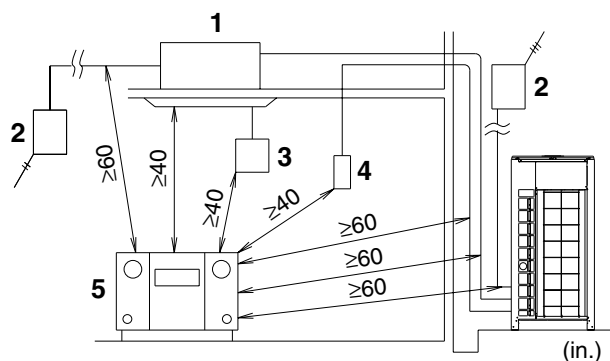

1. indoor unit
2. Branch switch, overcurrent breaker
3. remote controller
4. cool/heat selector
5. personal computer or radio

If the electric wave of AM broadcasting is particularly weak, keep distances of 10ft. or more and use conduit tubes for power and transmission lines.

2. In heavy snowfall areas, select an installation site where snow will not affect operation of the unit.
3. The refrigerant R410A itself is nontoxic, nonflammable and is safe. If the refrigerant should leak however, its concentration may exceed the allowable limit depending on room size. Due to this it could be necessary to take measures against leakage. Refer to the chapter "Caution for refrigerant leaks".
4. Do not install in the following locations.
  - Locations such as kitchens which contain a lot of mineral oil or steam in the atmosphere or where oil may splatter on the unit.  
Resin parts may deteriorate, causing the unit to fall or leak.
  - Locations where sulfurous acids and other corrosive gases may be present in the atmosphere.  
Copper piping and soldered joints may corrode, causing refrigerant to leak.
  - Locations where equipment that produces electromagnetic waves is found.  
The electromagnetic waves may cause the control system to malfunction, preventing normal operation.
  - Locations where flammable gases may leak, where thinner, gasoline, and other volatile substances are handled, or where carbon dust and other incendiary substances are found in the atmosphere.  
Leaked gas may accumulate around the unit, causing an explosion.

**Service Space**

It is extremely important that enough space is left when installing the equipment to allow routine servicing and maintenance to be carried out without undue hindrance. It is particularly important to bear in mind the work which will be required if the compressor needs to be replaced. (The layout of the pipework can sometimes cause considerable difficulties if the compressor needs to be changed.)

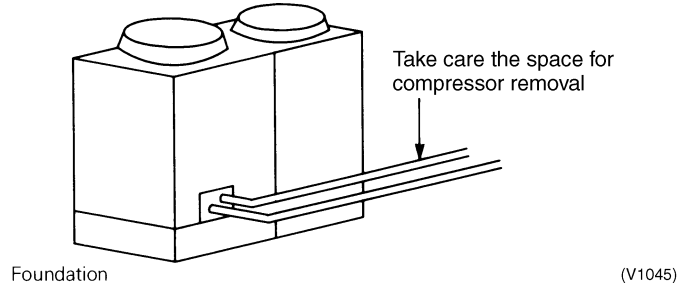

**3.2.13 Inspecting and Handling the Unit**

At delivery, the package should be checked and any damage should be reported immediately to the carrier claims agent.

When handling the unit, take into account the following:

1. Fragile, handle the unit with care.
2. Keep the unit upright in order to avoid compressor damage.
2. Choose the path along which the unit is to be brought in ahead of time.
3. If a forklift it to be used, pass the forklift arms through the large openings on the bottom of the unit.
4. Lift the unit preferably with a crane and 2 belts of at least 27ft. long.
5. When lifting the unit with a crane, always use protectors to prevent belt damage and pay attention to the position of the unit's centre of gravity.
6. After installation, remove the transport clasps attached to the large openings.
7. Bring the unit as close to its final installation position in its original package to prevent damage during transport.

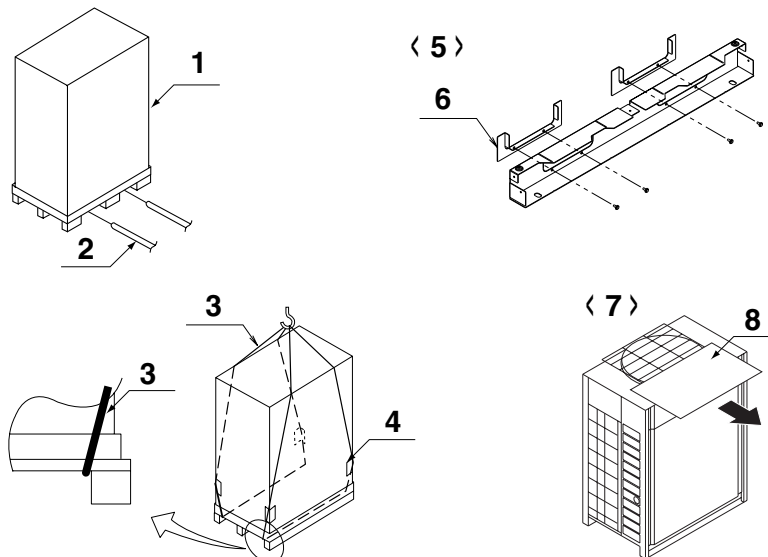

1. Packaging material
2. Forklift
3. Belt sling
4. Wear plate
5. Removal of shipping brackets
6. Shipping bracket (Remove the screws.)
7. Removal of corrugated paper
8. Corrugated paper



### 3.2.14 Installation of Outdoor Unit

■ Operational steps



(V1150)

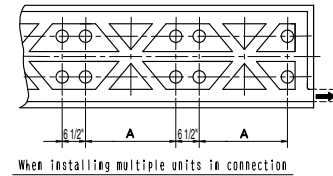
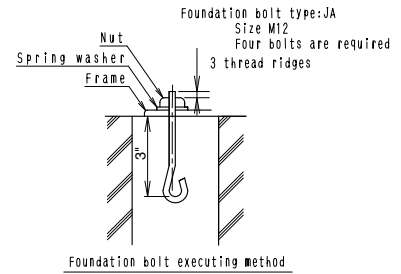
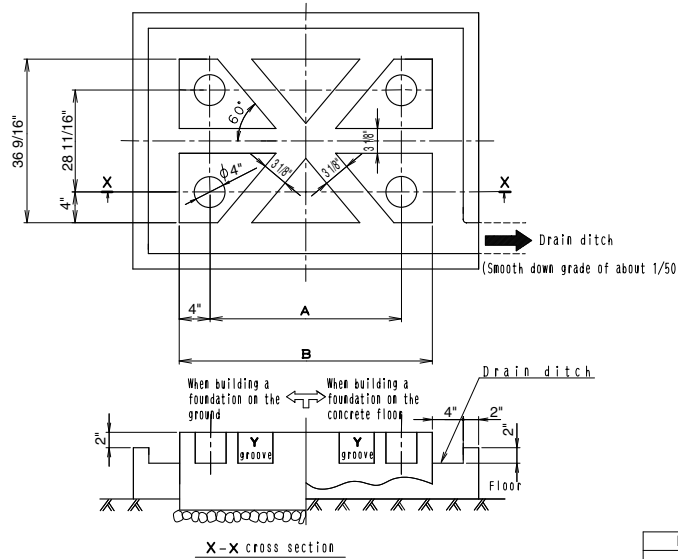

Model		A (in.)	B (in.)
12HP	REYQ96MTJU	43 3/8	51 3/8

3D040102A



**Note:**

1. The proportions of cement : sand : gravel for the concrete shall be 1 : 2 : 4, and ten reinforcement bars that their diameter are 6/16"-7/16", (approx. 12" intervals) shall be placed.
2. The surface shall be finished with mortar. The corner edges shall be chamfered.
3. When the foundation is built on a concrete floor, rubble is not necessary. However, the surface of the section on which the foundation is built shall have rough finish.
4. A drain ditch shall be made around the foundation to thoroughly drain water from the equipment installation area.
5. When installing the equipment on a roof, the floor strength shall be checked, and water-proofing measures shall be taken.

■ Bolt pitch

REYQ96MTJU

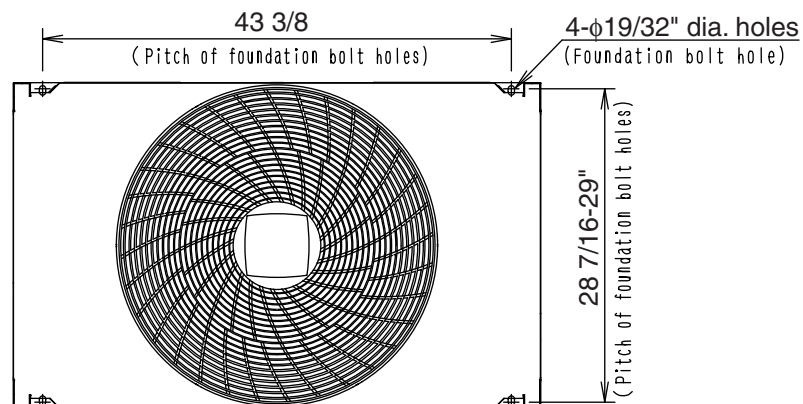

**Caution in installation**

- Execute the installation work by checking the foundation strength and levelness to avoid any occurrence of vibration and noise.  
Fix the unit tightly with foundation bolts. (Prepare 4 sets of M12 foundation bolts with proper nuts and washers.)  
The proper length of the foundation bolts from the surface of the base is 13/16".



**Caution**

Install the unit securely in case of earthquake an typhoon, cyclone, hurricane or other strong wind. The unit may topple or cause another accident if improperly set up.

**Unpacking and Placing the Unit**

- Make sure the unit is installed level on a sufficiently strong base to prevent vibration and noise.
- Secure the unit to its base using foundation bolts. (Use four commercially available M12-type foundation bolts, nuts, and washers.)
- The foundation bolts should be inserted 13/16".
- Make sure the base under the unit extended more than 30 1/8" behind the unit.
- The height of the base should be at least 5 7/8" from the floor.
- The unit must be installed on a solid longitudinal foundation (steelbeam frame or concrete) as indicated in the figure below.

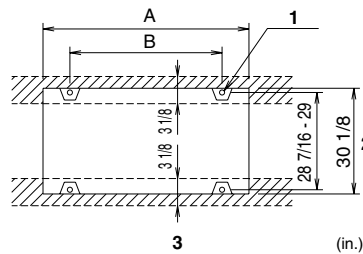
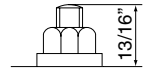

- Foundation bolt point ( $\phi 9/16$ " dia. : 4 positions)
- Depth of product
- Shape of indoor unit's support leg and foundation bolt positions

Model	A (in.)	B (in.)
Q96 type	48 13/16	43 3/8

**DO NOT USE STANDS TO SUPPORT THE CORNERS**

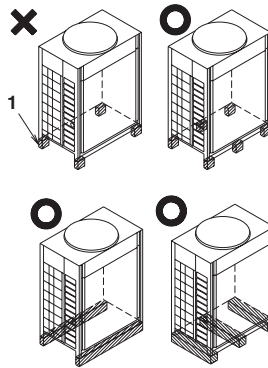

- Do not use stands to support the corners.



**Note:**

- Prepare a water drainage channel around the foundation to condensate waste water from around the unit.
- If the unit is to be installed on a roof, check the strength of the roof and its drainage facilities first.
- If the unit is to be installed on a frame, install the waterproofing board within a distance of 5 14/16" under the unit in order to prevent infiltration of water coming from under the unit.



- Note:**
- When installing on a roof, make sure the roof floor is strong enough and be sure to water-proof all work.
  - Make sure the area around the machine drains properly by setting up drainage grooves around the foundation.  
(Condensate water is sometimes discharged from the outdoor unit when it is running.)
  - Block all gaps in the holes for passing out piping and wiring using sealing material (locally procured).  
(Small animals may enter the machine.)

Ex: passing piping out through the front

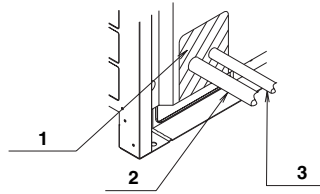

1. Plug the areas marked with "  ".  
(When the piping is routed from the front panel.)
2. Gas side piping
3. Liquid side piping



**Caution** Caution label

### To the installer

**How to remove the front panel**

- ① Remove the screws.
- ② Keep pressing the front panel with your hands and slide the panel downward. (The panel stops by the stopper.)
- ③ Pull the casing forward with your hands and slide the panel downward.

**How to mount the front panel**

- ① Mount the front panel leaving some clearance at the upper part and hook the panel to the stopper.
- ② Lift the panel and set the hole position.
- ③ Fasten the screws.

**How to remove the transport fixtures**

After the unit is installed, remove the transport fixture mounted on the opening (large).

3P124617

### ⚠ Attention in installation of EL,COMP,BOX COVER

- Please install it, In the back side lower part and pasting up seal materials compromise, and not to stop. (Right fig. reference)

<EL,COMP,BOX cross section>  
(The left side)

There is the fear that seal materials come close in power supply terminal block.

4P124614

## 4. Test Operation

### 4.1 Procedure and Outline

Follow the following procedure to conduct the initial test operation after installation.

#### 4.1.1 Check work prior to turn power supply on

Check the below items.

- Power wiring
- Control transmission wiring between units
- Earth wire



Check on refrigerant piping



Check on amount of refrigerant charge

- Is the wiring performed as specified?
- Are the designated wires used?
- Is the grounding work completed?
  - Use a 500V megger tester to measure the insulation.
    - Do not use a megger tester for other circuits than 200V (or 240v) circuit.
- Are the setscrews of wiring not loose?
- Is pipe size proper? (The design pressure of this product is 550 psi.)
- Are pipe insulation materials installed securely?
  - Liquid and gas pipes need to be insulated. (Otherwise causes water leak.)
- Are respective stop valves on liquid, gas and oil equalizing lines securely open?
- Is refrigerant charged up to the specified amount?
  - If insufficient, charge the refrigerant from the service port of stop valve on the liquid side with outdoor unit in stop mode after turning power on.
- Has the amount of refrigerant charge been recorded on “Record Chart of Additional Refrigerant Charge Amount”?

(V3055)

#### 4.1.2 Turn power on

Turn outdoor unit power on.



Carry out field setting on outdoor PC board



Turn indoor unit power on.

- Be sure to turn the power on 6 hours before starting operation to protect compressors. (to power on clankcase heater)
- For field settings, refer to “Field Settings” on and after P68.
  - After the completion of field settings, set to “Setting mode 1”.

(V3056)

### 4.1.3 Check Operation

- \* During check operation, mount front panel to avoid the misjudging.
- \* Check operation is mandatory for normal unit operation.  
(When the check operation is not executed, alarm code "U3" will be displayed.)

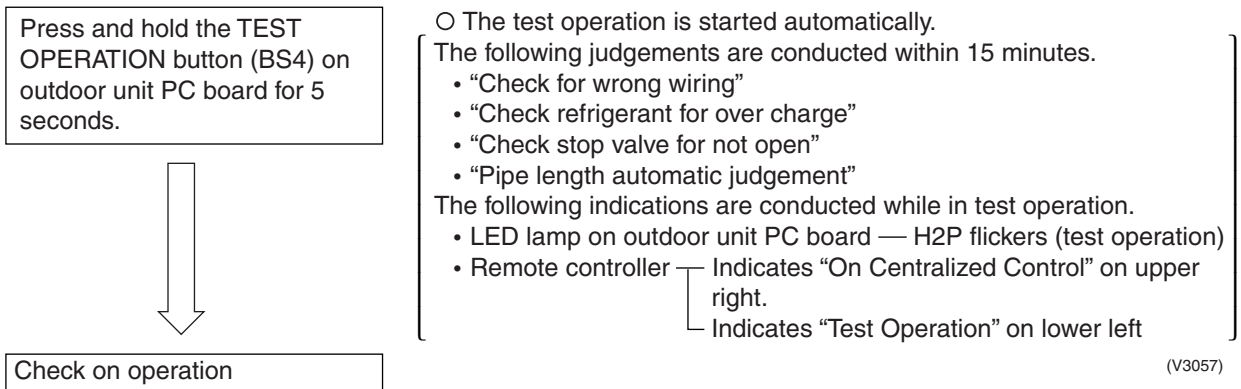

On completion of test operation, LED on outdoor unit PC board displays the following.  
 H3P ON: Normal completion  
 H2P and H3P ON: Abnormal completion →Check the indoor unit remote controller for abnormal display and correct it.

In the case of multi-outdoor-unit system, make setting on the master unit PC board. (Setting with the slave unit is disabled.)  
 [LED display in the case of multi-outdoor-unit system] (Same as that in emergency operation)

- \* Discriminate the operating status of the master unit/slave units through the following LED display.

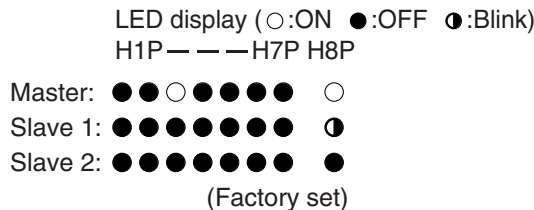

#### Malfunction code

In case of an alarm code displayed on remote controller:

Cause of trouble due to faulty installation work	Alarm code	Countermeasure
Closed stop valve of outdoor unit	E3 E4 F3	Liquid side stop valve : Open Gas side stop valve : Open Oil equalizing pipe stop valve : Close
Reversed phase in power cable connection for outdoor unit	U1	Change connection of two wires among three for correct phasing.
Electric power for outdoor or indoor unit is not supplied. (Including open phase)	U4	Check that the power cable for outdoor unit is connected properly.
Incorrect wiring between units	UF	Check that the wiring between units corresponds correctly to refrigerant piping system.
Refrigerant overcharge	E3 F6 UF	Compute again optimum amount of refrigerant to be added based on the piping length, then, collect the excessive amount by using refrigerant collector to make the refrigerant amount proper.
Insufficient refrigerant	E4 F3	- Check that additional charging has been carried out. - Compute again the refrigerant amount to be added based on the piping length, and charge proper amount of refrigerant additionally.

#### 4.1.4 Confirmation on normal operation

- Conduct normal unit operation after the check operation has been completed.  
(When outdoor air temperature is 75°F or higher, the unit can not be operated with heating mode. See the instruction manual attached.)  
Confirm that the indoor/outdoor units can be operated normally.  
(When an abnormal noise due to liquid compression by the compressor can be heard, stop the unit immediately, and turn on the crankcase heater to heat up it sufficiently, then start operation again.)
- Operate indoor unit one by one to check that the corresponding outdoor unit operates.
- Confirm that the indoor unit discharges cold air (or warm air).
- Operate the air direction control button and flow rate control button to check the function of the devices.

## 4.2 Operation When Power is Turned On

### 4.2.1 When Turning On Power First Time

The unit cannot be run for up to 12 minutes to automatically set the master power and address (indoor-outdoor address, etc.).

#### Status

Outdoor unit

Test lamp H2P .... Blinks

Can also be set during operation described above.

Indoor unit

If ON button is pushed during operation described above, the "UH" malfunction indicator blinks. (Returns to normal when automatic setting is complete.)

### 4.2.2 When Turning On Power The Second Time and Subsequent

Tap the RESET button on the outdoor unit PC board. Operation becomes possible for about 2 minutes. If you do not push the RESET button, the unit cannot be run for up to 10 minutes to automatically set master power.

#### Status

Outdoor unit

Test lamp H2P .... Blinks

Can also be set during operation described above.

Indoor unit

If ON button is pushed during operation described above, the operation lamp lights but the compressor does not operate. (Returns to normal when automatic setting is complete.)

### 4.2.3 When an Indoor Unit or Outdoor unit Has Been Added, or Indoor or Outdoor Unit PC Board Has Been Changed

Be sure to push and hold the RESET button for 5 seconds. If not, the addition cannot be recognized. In this case, the unit cannot be run for up to 12 minutes to automatically set the address (indoor-outdoor address, etc.)

#### Status

Outdoor unit

Test lamp H2P .... ON

Can also be set during operation described above.

Indoor unit

If ON button is pushed during operation described above, the "UH" or "U4" malfunction indicator blinks. (Returns to normal when automatic setting is complete.)



## 4.3 Outdoor Unit PC Board Layout

### Outdoor unit PC board

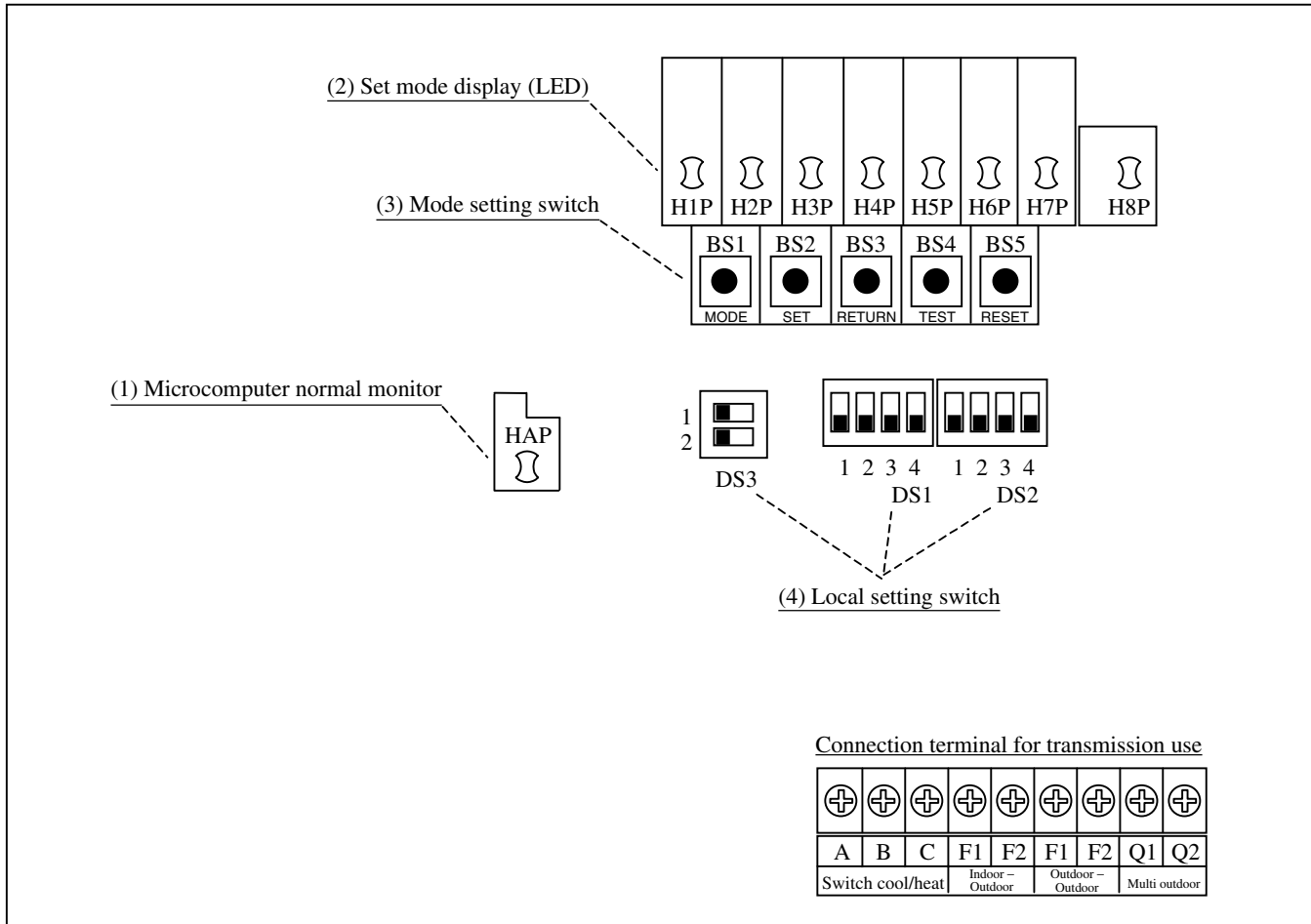

(V3054)

- (1) Microcomputer normal monitor  
This monitor blinks while in normal operation, and turns on or off when a malfunction occurs.
- (2) Set mode display (LED)  
LEDs display mode according to the setting.
- (3) Mode setting switch  
Used to change mode.
- (4) Local setting switch  
Used to make local settings.

## 4.4 Field Setting

### 4.4.1 Field Setting from Remote Controller

Individual function of indoor unit can be changed from the remote controller. At the time of installation or after service inspection / repair, make the local setting in accordance with the following description.



Wrong setting may cause malfunction.

(When optional accessory is mounted on the indoor unit, setting for the indoor unit may be required to change. Refer to information in the option handbook.)

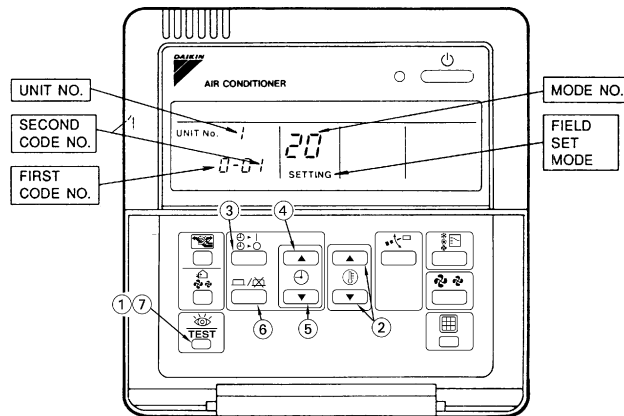



#### 4.4.1.1 Wired Remote Controller <BRC1C71>



2P068938-1

1. When in the normal mode, push the  button for 4 seconds or more, and operation then enters the "field set mode."
2. Select the desired "mode No." with the  button.
3. During group control and you want to set by each individual indoor unit (when mode No. 20, 21, 22, 23, 25 has been selected), push the time mode  button and select the "indoor unit No." to be set.

Note: This operation is not required when setting as a group.

4. Push the  button and select the first code No.
5. Push the  button and select the second code No.
6. Push the timer  button one time and "define" the currently set contents.
7. Push the  button to return to the normal mode.

(Example)

When setting the filter sign time to "Filter Dirtiness-High" in all group unit setting, set the Mode No. to "10", Mode setting No. to "0" and setting position No. to "02".

## 4.4.1.2 Setting Contents and Code No. – VRV Unit

VRV system indoor unit settings	Mode No. Note 2	Setting Switch No.	Setting Contents	Second Code No.(Note 3)								
				01		02		03		04		
10(20)	0		Filter contamination heavy/light (Setting for display time to clean air filter) (Sets display time to clean air filter to half when there is heavy filter contamination.)	Super long life filter	Light	Approx. 10,000 hrs.	Heavy	Approx. 5,000 hrs.	—	—		
				Long life filter		Approx. 2,500 hrs.		Approx. 1,250 hrs.				
				Standard filter		Approx. 200 hrs.		Approx. 100 hrs.				
	1		Long life filter type	Long life filter		Super long life filter		—	—			
	2		Thermostat sensor in remote controller	Use		No use		—	—			
	3		Display time to clean air filter calculation (Set when filter sign is not to be displayed.)	Display		No display		—	—			
	12(22)	0		Optional accessories output selection (field selection of output for adaptor for wiring)	Indoor unit turned ON by thermostat				Operation output		Malfunction output	
		1		ON/OFF input from outside (Set when ON/OFF is to be controlled from outside.)	Forced OFF		ON/OFF control		—	—		
		2		Thermostat differential changeover (Set when remote sensor is to be used.)	1°C		0.5°C		—	—		
		3		OFF by thermostat fan speed	LL		Set fan speed		—	—		
4			Automatic mode differential (automatic temperature differential setting for VRV system heat recovery series cool/heat)	01:0	02:1	03:2	04:3	05:4	06:5	07:6	08:7	
5			Power failure automatic reset	Not equipped		Equipped		—	—			
13(23)	0		High air outlet velocity (Set when installed in place with ceiling higher than 2.7 m.)	N		H		S		—		
	1		Selection of air flow direction (Set when a blocking pad kit has been installed.)	F (4 directions)		T (3 directions)		W (2 directions)		—		
	3		Air flow direction adjustment (Set at installation of decoration panel.)	Equipped		Not equipped		—	—			
	4		Field set air flow position setting	Draft prevention		Standard		Ceiling Soiling prevention		—		
	5		Field set fan speed selection (fan speed control by air discharge outlet for phase control)	Standard		Optional accessory 1		Optional accessory 2		—		
	15(25)	1		Thermostat OFF excess humidity	Not equipped		Equipped		—	—		
2			Direct duct connection (when the indoor unit and heat reclaim ventilation unit are connected by duct directly.) *Note 6	Not equipped		Equipped		—	—			
3			Drain pump humidifier interlock selection	Not equipped		Equipped		—	—			
5			Field set selection for individual ventilation setting by remote controller	Not equipped		Equipped		—	—			
6			Field set selection for individual ventilation setting by remote controller	Not equipped		Equipped		—	—			

**Notes:**

- Settings are made simultaneously for the entire group, however, if you select the mode No. inside parentheses, you can also set by each individual unit. Setting changes however cannot be checked except in the individual mode for those in parentheses.
- The mode numbers inside parentheses cannot be used by wireless remote controllers, so they cannot be set individually. Setting changes also cannot be checked.
- Marked   are factory set.
- Do not make settings other than those described above. Nothing is displayed for functions the indoor unit is not equipped with.
- “88” may be displayed to indicate the remote controller is resetting when returning to the normal mode.
- If the setting mode to “Equipped”, heat reclaim ventilation fan conducts the fan residual operation by linking to indoor unit.

#### 4.4.1.3 Applicable Range of Field setting

	Ceiling mounted cassette type	Ceiling mounted built-in type	Ceiling mounted duct type	Wall mounted type	Floor standing type	Concealed Floor standing type
	Multi flow					
	FXFQ	FXSQ	FXMQ	FXAQ	FXLQ	FXNQ
Filter sign	○	○	○	○	○	○
Ultra long life filter sign	○	—	—	—	—	—
Remote controller thermostat sensor	○	○	○	○	○	○
Set fan speed when thermostat OFF	○	○	○	○	○	○
Air flow adjustment Ceiling height	○	—	—	—	—	—
Air flow direction	○	—	—	—	—	—
Air flow direction adjustment (Down flow operation)	—	—	—	—	—	—
Air flow direction adjustment range	○	—	—	—	—	—
Field set fan speed selection	○	—	—	—	—	—

#### 4.4.1.4 Detailed Explanation of Setting Modes

##### Filter Sign Setting

If switching the filter sign ON time, set as given in the table below.

##### Set Time

Setting	Filter Specs.	Standard	Long Life	Ultra Long Life Filter
Contamination Light		200 hrs.	2,500 hrs.	10,000 hrs.
Contamination Heavy		100 hrs.	1,250 hrs.	5,000 hrs.

##### Ultra-Long-Life Filter Sign Setting

When a Ultra-long-life filter is installed, the filter sign timer setting must be changed.

##### Setting Table

Mode No.	Setting Switch No.	Setting Position No.	Setting
10 (20)	1	01	Long-Life Filter
		02	Ultra-Long-Life Filter (1)
		03	—

##### Fan Speed Changeover When Thermostat is OFF

By setting to “Set Fan Speed,” you can switch the fan speed to the set fan speed when the heating thermostat is OFF.

\* Since there is concern about draft if using “fan speed up when thermostat is OFF,” you should take the setup location into consideration.

##### Setting Table

Mode No.	First Code No.	Second Code No.	Setting
12(22)	3	01	LL Fan Speed
		02	Set Fan Speed

##### Auto Restart after Power Failure Reset

For the air conditioners with no setting for the function (same as factory setting), the units will be left in the stop condition when the power supply is reset automatically after power failure reset or the main power supply is turned on again after once turned off. However, for the air conditioners with the setting, the units may start automatically after power failure reset or the main power supply turned on again (return to the same operation condition as that of before power failure).

For the above reasons, when the unit is set enabling to utilize “Auto restart function after power failure reset”, utmost care should be paid for the occurrence of the following situation.



- Caution**
- 1. The air conditioner starts operation suddenly after power failure reset or the main power supply turned on again. Consequently, the user might be surprised (with question for the reason why).**
  - 2. In the service work, for example, turning off the main power switch during the unit is in operation, and turning on the switch again after the work is completed start the unit operation (the fan rotates).**

**Air Flow Adjustment - Ceiling Height**

Make the following setting according to the ceiling height. The setting position No. is set to “01” at the factory.

■ In the Case of FXAQ

Mode No.	Setting Switch No.	Setting Position No.	Setting
13(23)	0	01	Wall-mounted type : Standard
		02	Wall-mounted type : Slight increase
		03	Wall-mounted type : Normal increase

■ In the Case of FXFQ12~30

Mode No.	First code No.	Second code No.	Setting	Ceiling height		
				4-way Outlets	3-way Outlets	2-way Outlets
13 (23)	0	01	Standard (N)	Lower than 2.7 m	Lower than 3.0 m	Lower than 3.5 m
		02	High Ceiling (H)	Lower than 3.0 m	Lower than 3.3 m	Lower than 3.8 m
		03	Higher Ceiling (S)	Lower than 3.5 m	Lower than 3.5 m	—

■ In the Case of FXFQ36

Mode No.	First code No.	Second code No.	Setting	Ceiling height		
				4-way Outlets	3-way Outlets	2-way Outlets
13 (23)	0	01	Standard (N)	Lower than 3.2 m	Lower than 3.6 m	Lower than 4.2 m
		02	High Ceiling (H)	Lower than 3.6 m	Lower than 4.0 m	Lower than 4.2 m
		03	Higher Ceiling (S)	Lower than 4.2 m	Lower than 4.2 m	—

**Air Flow Direction Setting**

Set the air flow direction of indoor units as given in the table below. (Set when optional air outlet blocking pad has been installed.) The second code No. is factory set to “01.”

**Setting Table**

Mode No.	First Code No.	Second Code No.	Setting
13 (23)	1	01	F : 4-direction air flow
		02	T : 3-direction air flow
		03	W : 2-direction air flow

**Setting of Air  
Flow Direction  
Adjustment  
Range**

Make the following air flow direction setting according to the respective purpose.

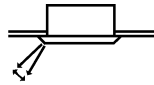

(S2537)

**Setting Table**

Mode No.	First Code No.	Second Code No.	Setting
13 (23)	4	01	Upward (Draft prevention)
		02	Standard
		03	Downward (Ceiling soiling prevention)







**Air Flow Rate  
Switching at  
Discharge Grille  
for Field Air Flow  
Rate Switching**

When the optional parts (high performance filter, etc.) is installed, sets to change fan speed for securing air flow rate.

Follow the instruction manual for the optional parts to enter the setting numbers.

#### 4.4.1.5 Centralized Control Group No. Setting

##### BRC1C Type

- If carrying out centralized control by central remote controller or unified ON/OFF controller, group No. must be set for each group individually by remote controller.
- Group No. setting by remote controller for centralized control
  1. When in the normal mode, push the  button for 4 seconds or more, and operation then enters the "field setting mode."
  2. Set mode No. "00" with the  button. \*
  3. Push the  button to inspect the group No. display.
  4. Set the group No. for each group with the  button (The group No. increases in the manner of 1-00, 1-01, ..., 1-15, 2-00, ..., 4-15. However, the unified ON/OFF controller displays only the group No. within the range selected by the switch for setting each address.)
  5. Push the timer  button to define the selected group No.
  6. Push the  button to return to the normal mode.

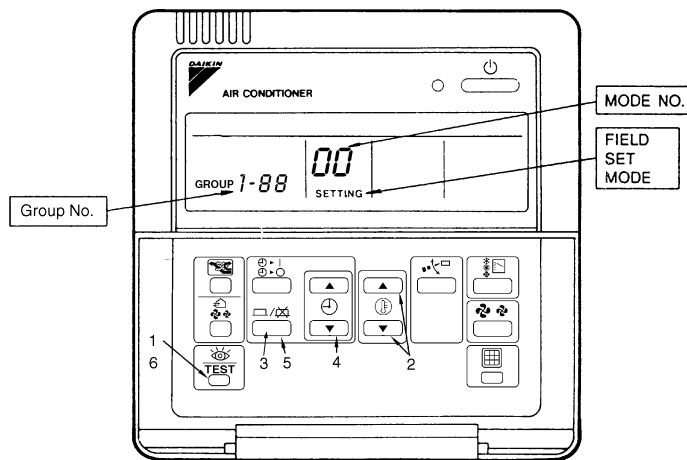

(S1095)

- Even if not using a remote controller, connect the remote controller when setting the group No., set the group No. for centralized control, and disconnect after making the setting.
- Set the group No. after turning on the power supply for the central remote controller, unified ON/OFF controller, and indoor unit.



### Group No. Setting Example

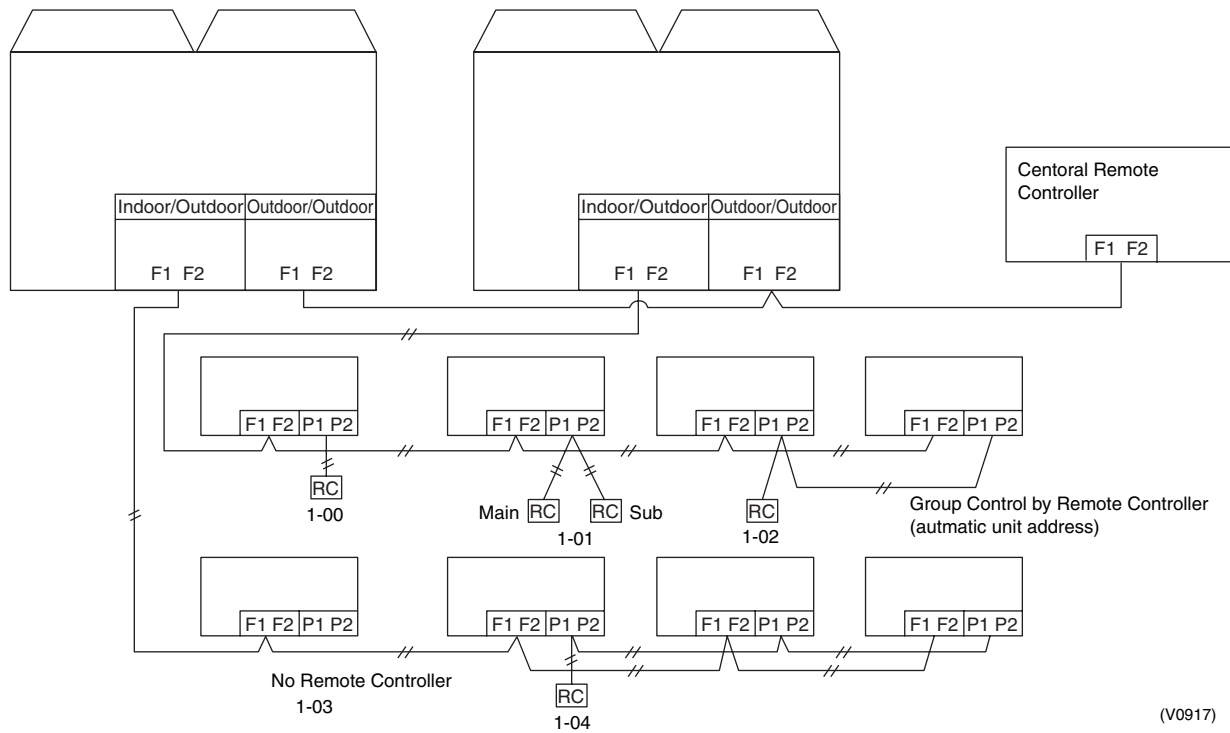

#### Caution

When turning the power supply on, the unit may often not accept any operation while "88" is displaying after all indications were displayed once for about 1 minute on the liquid crystal display. This is not an operative fault.

---

#### 4.4.1.6 Setting of Operation Control Mode from Remote Controller (Local Setting)

The operation control mode is compatible with a variety of controls and operations by limiting the functions of the operation remote controller. Furthermore, operations such as remote controller ON/OFF can be limited in accordance with the combination conditions. (Refer to information in the table below.)

Centralized controller is normally available for operations. (Except when centralized monitor is connected)

---

#### 4.4.1.7 Contents of Control Modes

Twenty modes consisting of combinations of the following five operation modes with temperature and operation mode setting by remote controller can be set and displayed by operation modes 0 through 19.

- ◆ ON/OFF control impossible by remote controller  
Used when you want to turn on/off by central remote controller only.  
(Cannot be turned on/off by remote controller.)
- ◆ OFF control only possible by remote controller  
Used when you want to turn on by central remote controller only, and off by remote controller only.
- ◆ Centralized  
Used when you want to turn on by central remote controller only, and turn on/off freely by remote controller during set time.
- ◆ Individual  
Used when you want to turn on/off by both central remote controller and remote controller.
- ◆ Timer operation possible by remote controller  
Used when you want to turn on/off by remote controller during set time and you do not want to start operation by central remote controller when time of system start is programmed.

**How to Select Operation Mode**

Whether operation by remote controller will be possible or not for turning on/off, controlling temperature or setting operation mode is selected and decided by the operation mode given on the right edge of the table below.

**Example**

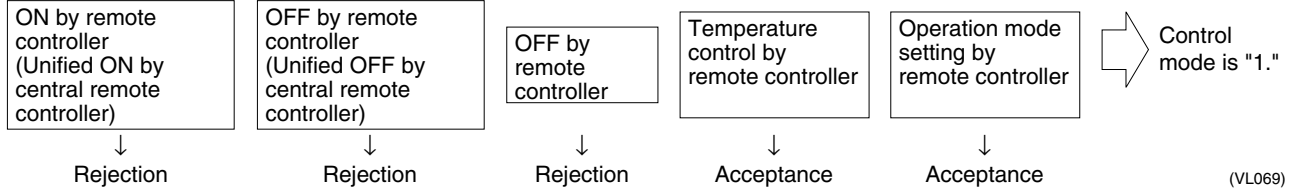

Control mode	Control by remote controller					Control mode
	Operation		OFF	Temperature control	Operation mode setting	
	Unified operation, individual operation by central remote controller, or operation controlled by timer	Unified OFF, individual stop by central remote controller, or timer stop				
ON/OFF control impossible by remote controller	Rejection (Example)	Rejection (Example)	Rejection (Example)	Rejection	Acceptance	0
OFF control only possible by remote controller				Acceptance (Example)	Acceptance (Example)	1 (Example)
	Centralized	Acceptance	Acceptance	Rejection	Acceptance	2
Acceptance				Acceptance	3	
Individual	Acceptance	Acceptance	Acceptance	Rejection	Acceptance	4
				Acceptance	Acceptance	5
Timer operation possible by remote controller	Acceptance (During timer at ON position only)	Acceptance (During timer at ON position only)	Acceptance	Rejection	Acceptance	6
				Acceptance	Acceptance	7 *1
				Rejection	Acceptance	8
				Acceptance	Acceptance	9
				Rejection	Acceptance	10
				Rejection	Acceptance	11
				Rejection	Acceptance	12
				Rejection	Acceptance	13
				Rejection	Acceptance	14
				Rejection	Acceptance	15
				Rejection	Acceptance	16
				Rejection	Acceptance	17
				Rejection	Acceptance	18
				Rejection	Acceptance	19

Do not select "timer operation possible by remote controller" if not using a remote controller. Operation by timer is impossible in this case.

\*1. Factory setting

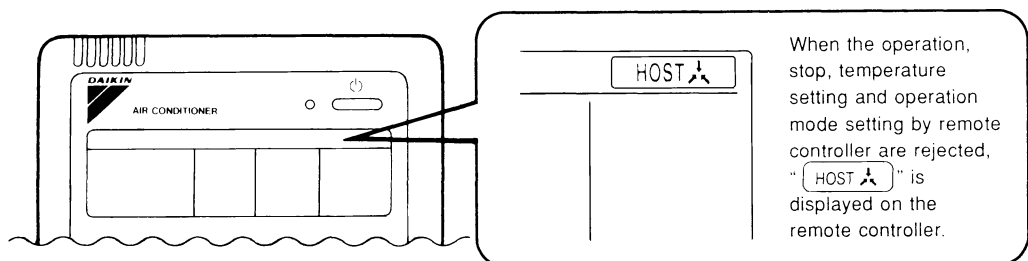

(VL070)

## 4.4.2 Field Setting from Outdoor Unit

### 4.4.2.1 Field Setting from Outdoor Unit

#### ■ Setting by dip switches

The following field settings are made by dip switches on PC board.

Dipswitch		Setting item	Description
No.	Setting		
DS1-1	ON	Cool / Heat select	Used to set cool / heat select by remote controller equipped with outdoor unit.
	OFF (Factory set)		
DS1-2 ~DS1-4	ON	Not used	Do not change the factory settings.
	OFF (Factory set)		
DS2-1 ~4	ON	Not used	Do not change the factory settings.
	OFF (Factory set)		
DS3-1, 2	ON	Not used	Do not change the factory settings.
	OFF (Factory set)		

### ■ Setting by pushbutton switches

The following settings are made by pushbutton switches on PC board.

In case of multi-outdoor unit system, various items should be set with the master unit.

(Setting with the slave unit is disabled.)

The master unit and slave unit can be discriminated with the LED indication as shown below.

	H1P	H2P	H3P	H4P	H5P	H6P	H7P	H8P
Master unit	●	●	○	●	●	●	●	○
Slave unit 1	●	●	●	●	●	●	●	◐
Slave unit 2	●	●	●	●	●	●	●	●

(Factory setting)

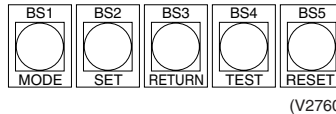

There are the following three setting modes.

#### ① Setting mode 1 (H1P off)

Initial status (when normal) : Indicates during “abnormal”, “low noise control” and “demand control”.

#### ② Setting mode 2 (H1P on)

Used to modify the operating status and to set program addresses, etc. Usually used in servicing the system.

#### ③ Monitor mode (H1P blinks)

Used to check the program made in Setting mode 2.

### ■ Mode changing procedure

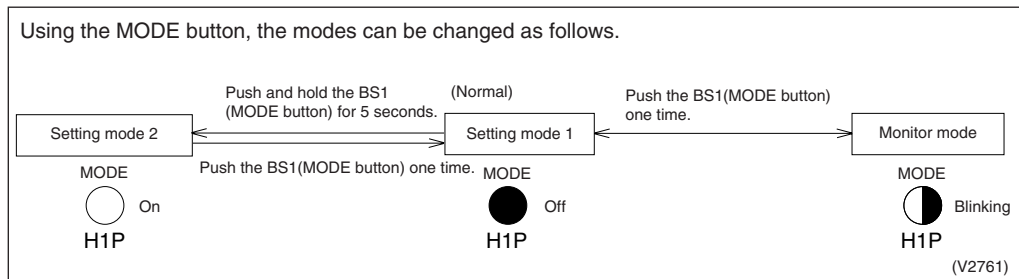

### ■ Mode changing procedure

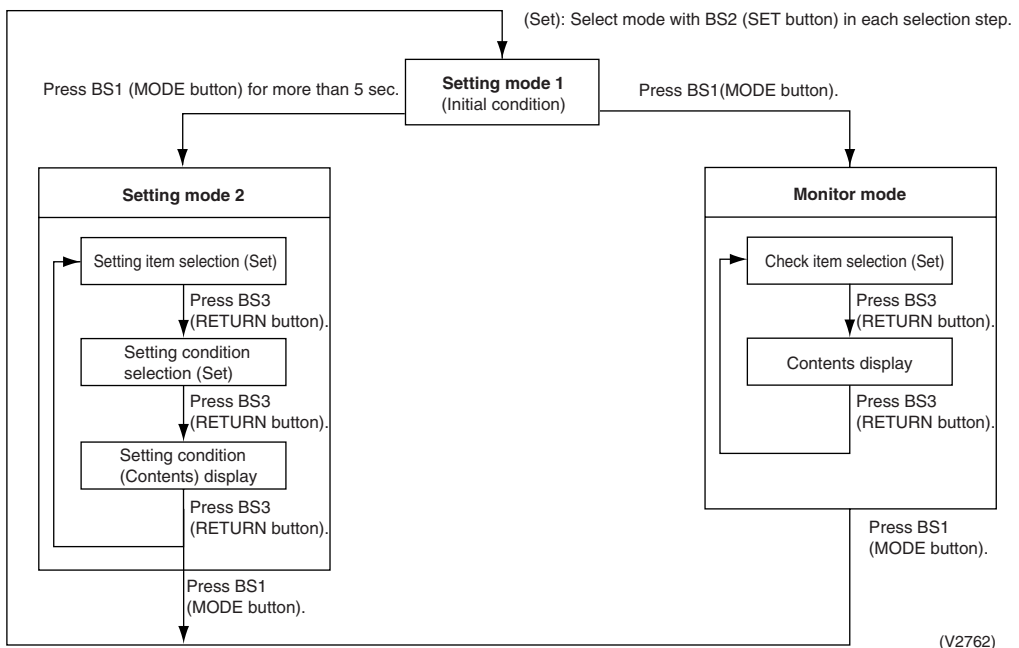

### a. "Setting mode 1"

"Normally, "Setting mode 1" is set. In case of other status, push MODE button (BS1) one time and set to "Setting mode 1".

<Selection of setting items>

Push the SET button (BS2) and set LED display to a setting item you want.

● Regarding setting item No. 1,5,6, only the present status is displayed. For the respective description, refer to the table shown on lower right.

When the RETURN button (BS3) is pushed, the status becomes the initial status of "Setting mode 1".

(V2763)

No.	Setting (displaying) item	LED display example						
		H1P	H2P	H3P	H4P	H5P	H6P	H7P
1	Display for malfunction / preparing / test run *	●	●	○	●	●	●	●
2	C/H selector (individual)	●	●	○	●	●	●	●
3	—							
4	—							
5	Low noise operation *	●	●	○	●	●	●	●
6	Demand operation *	●	●	○	●	●	●	●

\* Setting No. 1, 5, 6 are the present status display only.

#### Display for malfunction/preparing/test-run

Normal	●	●	○	●	●	●	●
Malfunction	●	○	○	●	●	●	●
Preparing/Test-run	●	◐	○	●	●	●	●

#### Display during low noise operation

Normal	●	●	○	●	●	●	●
During low noise operation	●	●	○	●	●	○	●

#### Display during demand operation

Normal	●	●	○	●	●	●	●
During demand operation	●	●	○	●	●	●	○

○ : ON
● : OFF
◐ : Blinking

## b. "Setting mode 2"

Push and hold the MODE button (BS1) for 5 seconds and set to "Setting mode 2".

### <Selection of setting items>

Push the SET button (BS2) and set the LED display to a setting item shown in the table on the right.

↓  
Push the RETURN button (BS3) and decide the item. (The present setting condition is blinked.)

### <Selection of setting conditions>

Push the SET button (BS2) and set to the setting condition you want.

↓  
Push the RETURN button (BS3) and decide the condition.

Push the RETURN button (BS3) and set to the initial status of "Setting mode 2".

\* If you become unsure of how to proceed, push the MODE button (BS1) and return to setting mode 1.

(V2764)

No.	Setting item	Description
0	EMG (Emergency operation 1)	Operates by Standard compressor only when inverter compressor malfunctions. Temporary operation until the compressor is replaced. Since the comfortability is extremely deteriorated, immediately replace the compressor. (This setting is not applicable to REYQ5M.)
1	—	—
2	Low noise/demand address	Address for low noise/demand operation
5	Indoor unit forced fan H	Allows forced operation of indoor unit fan while unit is stopped. (H tap)
6	Indoor unit forced operation	Allows forced operation of indoor unit.
8	Te setting	Target evaporation temperature for cooling
9	Tc setting	Target condensation temperature for heating
10	Defrost changeover setting	Changes the temperature condition for defrost and sets to quick defrost or slow defrost.
11	Sequential operation setting	Sets sequential operation
12	External low noise setting / Demand setting	Reception of external low noise or demand signal
13	AIRNET address	Set address for AIRNET.
18	High static pressure setting	Make this setting in the case of operating in high static pressure mode with diffuser duct mounted.
19	Emergency operation (STD compressor operation prohibited)	Used to operate system only with inverter compressor when STD compressor malfunctions. This is a temporary operation extremely impairing comfortable environment. Therefore, prompt replacement of the compressor is required. (This operation, however, is not set with REYQ5M.)
20	Additional refrigerant charge operation setting	Carries out additional refrigerant charge operation.
21	Refrigerant collection mode setting	Sets to refrigerant collection mode.
22	Night-time low noise setting	Sets automatic nighttime low noise operation in a simple way. The operating time is based on "Starting set" and "Ending set".
25	Low noise setting	Sets low noise level when the low noise signal is input from outside.
26	Night-time low noise control starting setting	Sets starting time of nighttime low noise operation. (Nighttime low noise setting is also required.)
27	Night-time low noise control ending setting	Sets ending time of nighttime low noise operation. (Nighttime low noise setting is also required.)
28	Power transistor check mode *Check after disconnection of compressor wires	Used for trouble diagnosis of DC compressor. Since the waveform of inverter is output without wiring to the compressor, it is convenient to probe whether the trouble comes from the compressor or PC board.
29	Capacity precedence setting	If the capacity control is required, the low noise control is automatically released by this setting during carrying out low noise operation and nighttime low noise operation.
30	Demand setting 1	Changes target value of power consumption when demand control 1 is input.
32	Normal demand setting	Normally enables demand control 1 without external input. (Effective to prevent a problem that circuit breaker of small capacity is shut down due to large load.)

No.	Setting item display								Setting condition display	
	Setting item	MODE H1P	TEST H2P	C/H selection			Low noise H6P	Demand H7P		
				IND H3P	Master H4P	Slave H5P				
0	EMG (emergency operation) INV compressor operation inhibited.	<input type="radio"/>	<input checked="" type="radio"/>	<input checked="" type="radio"/>	<input checked="" type="radio"/>	<input checked="" type="radio"/>	<input checked="" type="radio"/>	<input checked="" type="radio"/>	Normal operation	<input type="radio"/> <input checked="" type="radio"/> <input checked="" type="radio"/> <input checked="" type="radio"/> <input checked="" type="radio"/> <input checked="" type="radio"/> <input checked="" type="radio"/> <input checked="" type="radio"/> <input checked="" type="radio"/> <input checked="" type="radio"/> <input type="radio"/> *
									Emergency operation	<input type="radio"/> <input checked="" type="radio"/> <input checked="" type="radio"/> <input checked="" type="radio"/> <input checked="" type="radio"/> <input checked="" type="radio"/> <input checked="" type="radio"/> <input checked="" type="radio"/> <input checked="" type="radio"/> <input checked="" type="radio"/> <input checked="" type="radio"/>
1	—									
2	Low noise/demand address	<input type="radio"/>	<input checked="" type="radio"/>	<input checked="" type="radio"/>	<input checked="" type="radio"/>	<input checked="" type="radio"/>	<input type="radio"/>	<input checked="" type="radio"/>	Address 0	<input type="radio"/> <input checked="" type="radio"/> <input checked="" type="radio"/> <input checked="" type="radio"/> <input checked="" type="radio"/> <input checked="" type="radio"/> <input checked="" type="radio"/> <input checked="" type="radio"/> <input checked="" type="radio"/> <input checked="" type="radio"/> <input checked="" type="radio"/> *
									Binary number (6 digits)	1 <input type="radio"/> <input checked="" type="radio"/> <input checked="" type="radio"/> <input checked="" type="radio"/> <input checked="" type="radio"/> <input checked="" type="radio"/> <input type="radio"/>
									~	31 <input type="radio"/> <input checked="" type="radio"/> <input type="radio"/> <input type="radio"/> <input type="radio"/> <input type="radio"/> <input type="radio"/>
5	Indoor forced fan H	<input type="radio"/>	<input checked="" type="radio"/>	<input checked="" type="radio"/>	<input checked="" type="radio"/>	<input type="radio"/>	<input checked="" type="radio"/>	<input type="radio"/>	Normal operation	<input type="radio"/> <input checked="" type="radio"/> <input checked="" type="radio"/> <input checked="" type="radio"/> <input checked="" type="radio"/> <input checked="" type="radio"/> <input checked="" type="radio"/> <input checked="" type="radio"/> <input checked="" type="radio"/> <input checked="" type="radio"/> <input checked="" type="radio"/> *
									Indoor forced fan H	<input type="radio"/> <input checked="" type="radio"/> <input checked="" type="radio"/> <input checked="" type="radio"/> <input checked="" type="radio"/> <input checked="" type="radio"/> <input checked="" type="radio"/> <input checked="" type="radio"/> <input checked="" type="radio"/> <input checked="" type="radio"/> <input checked="" type="radio"/>
6	Indoor forced operation	<input type="radio"/>	<input checked="" type="radio"/>	<input checked="" type="radio"/>	<input checked="" type="radio"/>	<input type="radio"/>	<input type="radio"/>	<input checked="" type="radio"/>	Normal operation	<input type="radio"/> <input checked="" type="radio"/> <input checked="" type="radio"/> <input checked="" type="radio"/> <input checked="" type="radio"/> <input checked="" type="radio"/> <input checked="" type="radio"/> <input checked="" type="radio"/> <input checked="" type="radio"/> <input checked="" type="radio"/> <input checked="" type="radio"/> *
									Indoor forced operation	<input type="radio"/> <input checked="" type="radio"/> <input checked="" type="radio"/> <input checked="" type="radio"/> <input checked="" type="radio"/> <input checked="" type="radio"/> <input checked="" type="radio"/> <input checked="" type="radio"/> <input checked="" type="radio"/> <input checked="" type="radio"/> <input checked="" type="radio"/>
8	Te setting	<input type="radio"/>	<input checked="" type="radio"/>	<input checked="" type="radio"/>	<input type="radio"/>	<input checked="" type="radio"/>	<input checked="" type="radio"/>	<input checked="" type="radio"/>	High	<input type="radio"/> <input checked="" type="radio"/> <input checked="" type="radio"/> <input checked="" type="radio"/> <input type="radio"/> <input checked="" type="radio"/> <input checked="" type="radio"/> <input checked="" type="radio"/>
									Normal (factory setting)	<input type="radio"/> <input checked="" type="radio"/> <input checked="" type="radio"/> <input checked="" type="radio"/> <input checked="" type="radio"/> <input checked="" type="radio"/> <input checked="" type="radio"/> <input checked="" type="radio"/> <input checked="" type="radio"/> <input checked="" type="radio"/> <input checked="" type="radio"/> *
									Low	<input type="radio"/> <input checked="" type="radio"/> <input checked="" type="radio"/> <input checked="" type="radio"/> <input checked="" type="radio"/> <input checked="" type="radio"/> <input checked="" type="radio"/> <input checked="" type="radio"/> <input checked="" type="radio"/> <input checked="" type="radio"/> <input type="radio"/>
9	Tc setting	<input type="radio"/>	<input checked="" type="radio"/>	<input checked="" type="radio"/>	<input type="radio"/>	<input checked="" type="radio"/>	<input checked="" type="radio"/>	<input type="radio"/>	High	<input type="radio"/> <input checked="" type="radio"/> <input checked="" type="radio"/> <input checked="" type="radio"/> <input type="radio"/> <input checked="" type="radio"/> <input checked="" type="radio"/> <input checked="" type="radio"/>
									Normal (factory setting)	<input type="radio"/> <input checked="" type="radio"/> <input checked="" type="radio"/> <input checked="" type="radio"/> <input checked="" type="radio"/> <input checked="" type="radio"/> <input checked="" type="radio"/> <input checked="" type="radio"/> <input checked="" type="radio"/> <input checked="" type="radio"/> <input checked="" type="radio"/> *
									Low	<input type="radio"/> <input checked="" type="radio"/> <input checked="" type="radio"/> <input checked="" type="radio"/> <input checked="" type="radio"/> <input checked="" type="radio"/> <input checked="" type="radio"/> <input checked="" type="radio"/> <input checked="" type="radio"/> <input checked="" type="radio"/> <input type="radio"/>
10	Defrost setting	<input type="radio"/>	<input checked="" type="radio"/>	<input checked="" type="radio"/>	<input type="radio"/>	<input checked="" type="radio"/>	<input type="radio"/>	<input checked="" type="radio"/>	Quick defrost	<input type="radio"/> <input checked="" type="radio"/> <input checked="" type="radio"/> <input checked="" type="radio"/> <input type="radio"/> <input checked="" type="radio"/> <input checked="" type="radio"/> <input checked="" type="radio"/>
									Normal (factory setting)	<input type="radio"/> <input checked="" type="radio"/> <input checked="" type="radio"/> <input checked="" type="radio"/> <input checked="" type="radio"/> <input checked="" type="radio"/> <input checked="" type="radio"/> <input checked="" type="radio"/> <input checked="" type="radio"/> <input checked="" type="radio"/> <input checked="" type="radio"/> *
									Slow defrost	<input type="radio"/> <input checked="" type="radio"/> <input checked="" type="radio"/> <input checked="" type="radio"/> <input checked="" type="radio"/> <input checked="" type="radio"/> <input checked="" type="radio"/> <input checked="" type="radio"/> <input checked="" type="radio"/> <input checked="" type="radio"/> <input type="radio"/>
11	Sequential operation setting	<input type="radio"/>	<input checked="" type="radio"/>	<input checked="" type="radio"/>	<input type="radio"/>	<input checked="" type="radio"/>	<input type="radio"/>	<input type="radio"/>	OFF	<input type="radio"/> <input checked="" type="radio"/> <input checked="" type="radio"/> <input checked="" type="radio"/> <input checked="" type="radio"/> <input checked="" type="radio"/> <input checked="" type="radio"/> <input checked="" type="radio"/> <input checked="" type="radio"/> <input checked="" type="radio"/> <input type="radio"/>
									ON	<input type="radio"/> <input checked="" type="radio"/> <input checked="" type="radio"/> <input checked="" type="radio"/> <input checked="" type="radio"/> <input checked="" type="radio"/> <input checked="" type="radio"/> <input checked="" type="radio"/> <input checked="" type="radio"/> <input checked="" type="radio"/> <input checked="" type="radio"/> *
12	External low noise/demand setting	<input type="radio"/>	<input checked="" type="radio"/>	<input checked="" type="radio"/>	<input type="radio"/>	<input type="radio"/>	<input checked="" type="radio"/>	<input checked="" type="radio"/>	External low noise/demand: NO	<input type="radio"/> <input checked="" type="radio"/> <input checked="" type="radio"/> <input checked="" type="radio"/> <input checked="" type="radio"/> <input checked="" type="radio"/> <input checked="" type="radio"/> <input checked="" type="radio"/> <input checked="" type="radio"/> <input checked="" type="radio"/> <input type="radio"/> *
									External low noise/demand: YES	<input type="radio"/> <input checked="" type="radio"/> <input checked="" type="radio"/> <input checked="" type="radio"/> <input checked="" type="radio"/> <input checked="" type="radio"/> <input checked="" type="radio"/> <input checked="" type="radio"/> <input checked="" type="radio"/> <input checked="" type="radio"/> <input checked="" type="radio"/>
13	Airnet address	<input type="radio"/>	<input checked="" type="radio"/>	<input checked="" type="radio"/>	<input type="radio"/>	<input type="radio"/>	<input checked="" type="radio"/>	<input type="radio"/>	Address 0	<input type="radio"/> <input checked="" type="radio"/> <input checked="" type="radio"/> <input checked="" type="radio"/> <input checked="" type="radio"/> <input checked="" type="radio"/> <input checked="" type="radio"/> <input checked="" type="radio"/> <input checked="" type="radio"/> <input checked="" type="radio"/> <input checked="" type="radio"/> *
									Binary number (6 digits)	1 <input type="radio"/> <input checked="" type="radio"/> <input checked="" type="radio"/> <input checked="" type="radio"/> <input checked="" type="radio"/> <input checked="" type="radio"/> <input type="radio"/>
									~	63 <input type="radio"/> <input checked="" type="radio"/> <input type="radio"/> <input type="radio"/> <input type="radio"/> <input type="radio"/> <input type="radio"/>
18	High static pressure setting	<input type="radio"/>	<input checked="" type="radio"/>	<input type="radio"/>	<input checked="" type="radio"/>	<input checked="" type="radio"/>	<input type="radio"/>	<input checked="" type="radio"/>	High static pressure setting: OFF	<input type="radio"/> <input checked="" type="radio"/> <input checked="" type="radio"/> <input checked="" type="radio"/> <input checked="" type="radio"/> <input checked="" type="radio"/> <input checked="" type="radio"/> <input checked="" type="radio"/> <input checked="" type="radio"/> <input checked="" type="radio"/> <input checked="" type="radio"/> *
									High static pressure setting: ON	<input type="radio"/> <input checked="" type="radio"/> <input checked="" type="radio"/> <input checked="" type="radio"/> <input checked="" type="radio"/> <input checked="" type="radio"/> <input checked="" type="radio"/> <input checked="" type="radio"/> <input checked="" type="radio"/> <input checked="" type="radio"/> <input checked="" type="radio"/>
19	Emergency operation (STD compressor is inhibited to operate.)	<input type="radio"/>	<input checked="" type="radio"/>	<input type="radio"/>	<input checked="" type="radio"/>	<input checked="" type="radio"/>	<input type="radio"/>	<input type="radio"/>	OFF	<input type="radio"/> <input checked="" type="radio"/> <input checked="" type="radio"/> <input checked="" type="radio"/> <input checked="" type="radio"/> <input checked="" type="radio"/> <input checked="" type="radio"/> <input checked="" type="radio"/> <input checked="" type="radio"/> <input checked="" type="radio"/> <input checked="" type="radio"/> *
									STD 1, 2 operation: Inhibited	<input type="radio"/> <input checked="" type="radio"/> <input checked="" type="radio"/> <input checked="" type="radio"/> <input checked="" type="radio"/> <input checked="" type="radio"/> <input checked="" type="radio"/> <input checked="" type="radio"/> <input checked="" type="radio"/> <input checked="" type="radio"/> <input type="radio"/>
									STD 2 operation: Inhibited	<input type="radio"/> <input checked="" type="radio"/> <input checked="" type="radio"/> <input checked="" type="radio"/> <input checked="" type="radio"/> <input checked="" type="radio"/> <input checked="" type="radio"/> <input checked="" type="radio"/> <input checked="" type="radio"/> <input checked="" type="radio"/> <input checked="" type="radio"/>
20	Additional refrigerant operation setting	<input type="radio"/>	<input checked="" type="radio"/>	<input type="radio"/>	<input checked="" type="radio"/>	<input type="radio"/>	<input checked="" type="radio"/>	<input checked="" type="radio"/>	Refrigerant charging: OFF	<input type="radio"/> <input checked="" type="radio"/> <input checked="" type="radio"/> <input checked="" type="radio"/> <input checked="" type="radio"/> <input checked="" type="radio"/> <input checked="" type="radio"/> <input checked="" type="radio"/> <input checked="" type="radio"/> <input checked="" type="radio"/> <input type="radio"/> *
									Refrigerant charging: ON	<input type="radio"/> <input checked="" type="radio"/> <input checked="" type="radio"/> <input checked="" type="radio"/> <input checked="" type="radio"/> <input checked="" type="radio"/> <input checked="" type="radio"/> <input checked="" type="radio"/> <input checked="" type="radio"/> <input checked="" type="radio"/> <input checked="" type="radio"/>
21	Refrigerant recovery mode setting	<input type="radio"/>	<input checked="" type="radio"/>	<input type="radio"/>	<input checked="" type="radio"/>	<input type="radio"/>	<input checked="" type="radio"/>	<input type="radio"/>	Refrigerant recovery: OFF	<input type="radio"/> <input checked="" type="radio"/> <input checked="" type="radio"/> <input checked="" type="radio"/> <input checked="" type="radio"/> <input checked="" type="radio"/> <input checked="" type="radio"/> <input checked="" type="radio"/> <input checked="" type="radio"/> <input checked="" type="radio"/> <input type="radio"/> *
									Refrigerant recovery: ON	<input type="radio"/> <input checked="" type="radio"/> <input checked="" type="radio"/> <input checked="" type="radio"/> <input checked="" type="radio"/> <input checked="" type="radio"/> <input checked="" type="radio"/> <input checked="" type="radio"/> <input checked="" type="radio"/> <input checked="" type="radio"/> <input checked="" type="radio"/>
22	Night-time low noise setting	<input type="radio"/>	<input checked="" type="radio"/>	<input type="radio"/>	<input checked="" type="radio"/>	<input type="radio"/>	<input type="radio"/>	<input checked="" type="radio"/>	OFF	<input type="radio"/> <input checked="" type="radio"/> <input checked="" type="radio"/> <input checked="" type="radio"/> <input checked="" type="radio"/> <input checked="" type="radio"/> <input checked="" type="radio"/> <input checked="" type="radio"/> <input checked="" type="radio"/> <input checked="" type="radio"/> <input checked="" type="radio"/> *
									Level 1 (outdoor fan with 8 step or lower)	<input type="radio"/> <input checked="" type="radio"/> <input checked="" type="radio"/> <input checked="" type="radio"/> <input checked="" type="radio"/> <input checked="" type="radio"/> <input checked="" type="radio"/> <input checked="" type="radio"/> <input checked="" type="radio"/> <input checked="" type="radio"/> <input type="radio"/>
									Level 2 (outdoor fan with 7 step or lower)	<input type="radio"/> <input checked="" type="radio"/> <input checked="" type="radio"/> <input checked="" type="radio"/> <input checked="" type="radio"/> <input checked="" type="radio"/> <input checked="" type="radio"/> <input checked="" type="radio"/> <input checked="" type="radio"/> <input checked="" type="radio"/> <input checked="" type="radio"/>
									Level 3 (outdoor fan with 6 step or lower)	<input type="radio"/> <input checked="" type="radio"/> <input checked="" type="radio"/> <input checked="" type="radio"/> <input checked="" type="radio"/> <input checked="" type="radio"/> <input checked="" type="radio"/> <input checked="" type="radio"/> <input checked="" type="radio"/> <input checked="" type="radio"/> <input type="radio"/>



No.	Setting item display								Setting condition display	
	Setting item	MODE H1P	TEST H2P	C/H selection			Low noise H6P	Demand H7P		
				IND H3P	Master H4P	Slave H5P				
25	Low noise setting	○	●	○	○	●	●	○	Level 1 (outdoor fan with 8 step or lower)	○ ● ● ● ● ● ● ● ○
									Level 2 (outdoor fan with 7 step or lower)	○ ● ● ● ● ● ○ ● *
									Level 3 (outdoor fan with 6 step or lower)	○ ● ● ● ● ○ ● ●
26	Night-time low noise operation start setting	○	●	○	○	●	○	●	About 20:00	○ ● ● ● ● ● ● ○
									About 22:00 (factory setting)	○ ● ● ● ● ● ○ ● *
									About 24:00	○ ● ● ● ● ○ ● ●
27	Night-time low noise operation end setting	○	●	○	○	●	○	○	About 6:00	○ ● ● ● ● ● ● ○
									About 7:00	○ ● ● ● ● ● ○ ●
									About 8:00 (factory setting)	○ ● ● ● ● ○ ● ● *
28	Power transistor check mode	○	●	○	○	○	●	●	OFF	○ ● ● ● ● ● ● ○ *
									ON	○ ● ● ● ● ● ○ ●
29	Capacity precedence setting	○	●	○	○	○	●	○	OFF	○ ● ● ● ● ● ● ○ *
									ON	○ ● ● ● ● ● ○ ●
30	Demand setting 1	○	●	○	○	○	○	○	60 % demand	○ ● ● ● ● ● ● ○
									70 % demand	○ ● ● ● ● ● ○ ● *
									80 % demand	○ ● ● ● ● ○ ● ●
32	Continuous demand setting	○	○	●	●	●	●	●	OFF	○ ● ● ● ● ● ● ○ *
									ON	○ ● ● ● ● ● ○ ●

**c. Monitor mode**

To enter the monitor mode, push the MODE button (BS1) when in "Setting mode 1".

**<Selection of setting item>**

Push the SET button (BS2) and set the LED display to a setting item.

**<Confirmation on setting contents>**

Push the RETURN button (BS3) to display different data of set items.

Push the RETURN button (BS3) and switches to the initial status of "Monitor mode".

\* Push the MODE button (BS1) and returns to "Setting mode 1".

(V2765)

No.	Setting item	LED display							Data display
		H1P	H2P	H3P	H4P	H5P	H6P	H7P	
0	Number of units for sequential starting, and others	●	●	●	●	●	●	●	See below
1	—								Lower 6 digits
2	Low noise/demand address	●	●	●	●	○	○	○	
3	Not used	●	●	●	●	○	○	○	
4	Airnet address	●	●	●	●	○	○	○	
5	Number of connected indoor units	●	●	●	●	○	○	○	
6	Number of connected BS units	●	●	●	●	○	○	○	
7	Number of connected zone units (excluding outdoor and BS unit)	●	●	●	●	○	○	○	Lower 4 digits: upper
8	Number of outdoor units	●	●	●	○	○	○	○	
9	Number of connected BS units	●	●	●	○	○	○	○	Lower 4 digits: lower
10	Number of connected BS units	●	●	●	○	○	○	○	Lower 6 digits
11	Number of zone units (excluding outdoor and BS unit)	●	●	●	○	○	○	○	Lower 4 digits: upper
12	Number of terminal blocks	●	●	●	○	○	○	○	Lower 4 digits: lower
13	Number of terminal blocks	●	●	●	○	○	○	○	Malfunction code table
14	Contents of malfunction (the latest)	○	●	●	○	○	○	○	
15	Contents of malfunction (1 cycle before)	○	●	○	○	○	○	○	
16	Contents of malfunction (2 cycle before)	○	●	○	○	○	○	○	
20	Contents of retry (the latest)	○	●	○	○	○	○	○	
21	Contents of retry (1 cycle before)	○	●	○	○	○	○	○	Malfunction code table
22	Contents of retry (2 cycle before)	○	●	○	○	○	○	○	

**Setting item 0 Display contents of "Number of units for sequential start, and others"**

Number of units for sequential start	1 unit	●	●	●	●	●	●	●
	2 units	●	●	○	○	○	○	○
	3 units	●	●	○	○	○	○	○
EMG operation /backup operation setting	ON	●	●	●	○	○	○	○
	OFF	●	●	●	○	○	○	○
Defrost select setting	Short	●	●	●	○	○	○	○
	Medium	●	●	●	○	○	○	○
	Long	●	●	●	○	○	○	○
Te setting	H	●	●	●	○	○	○	○
	M	●	●	●	○	○	○	○
	L	●	●	●	○	○	○	○
Tc setting	H	●	●	●	○	○	○	○
	M	●	●	●	○	○	○	○
	L	●	●	●	○	○	○	○

Push the SET button and match with the LEDs No. 1 - 15, push the RETURN button, and enter the data for each setting.

★ Data such as addresses and number of units is expressed as binary numbers; the two ways of expressing are as follows:

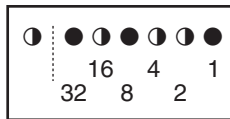

The No. 1 cool/heat unified address is expressed as a binary number consisting of the lower 6 digits. (0 - 63)

In ① the address is 010110 (binary number), which translates to  $16 + 4 + 2 = 22$  (base 10 number). In other words, the address is 22.

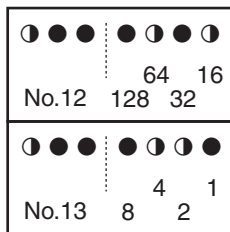

The number of terminal blocks for No. 12 and 13 is expressed as an 8-digit binary number, which is the combination of four upper, and four lower digits for No. 12 and 13 respectively. (0 - 128)

In ② the address for No. 12 is 0101, the address for No. 13 is 0110, and the combination of the two is 01010110 (binary number), which translates to  $64 + 16 + 4 + 2 = 86$  (base 10 number). In other words, the number of terminal block is 86..

★ See the preceding page for a list of data, etc. for No. 0 - 22.

### 4.4.2.2 Cool / Heat Mode Switching

#### Set Cool/Heat Separately for Each BS Unit by Cool/Heat Selector.

Set remote controller change over switch (SS1, SS2) as following:

- When using COOL/HEAT selector, turn this switch to the BS side.

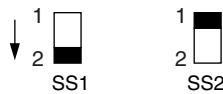

NOTE: This setting must be completed before turning power supply ON.

When using cool/heat selector, connect to the terminal A, B and C on the EC of the electric parts box.

#### EXAMPLE OF TRANSMISSION LINE CONNECTION

- Example of connecting transmission wiring.  
Connect the transmission wirings as shown in the Fig. 1.

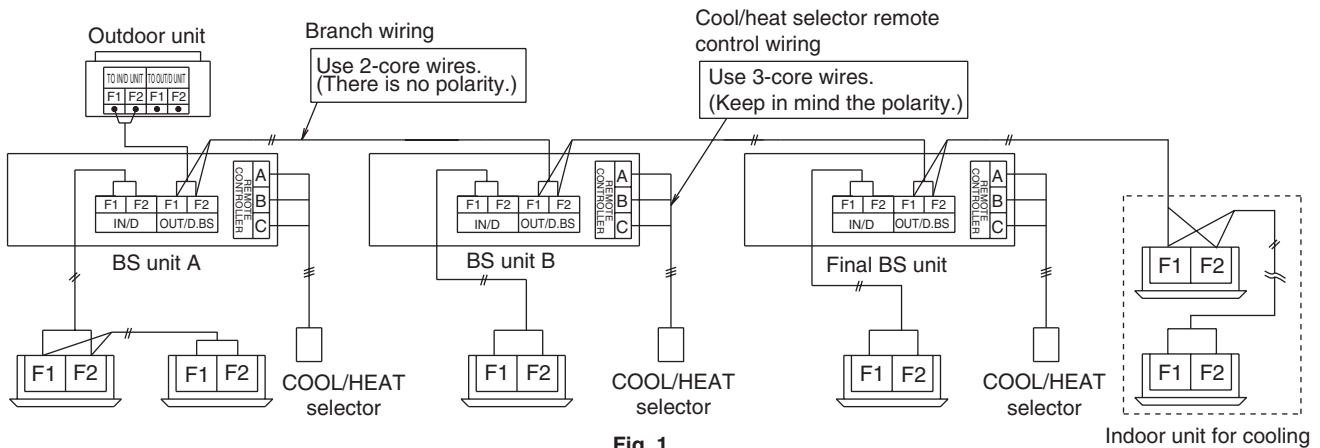
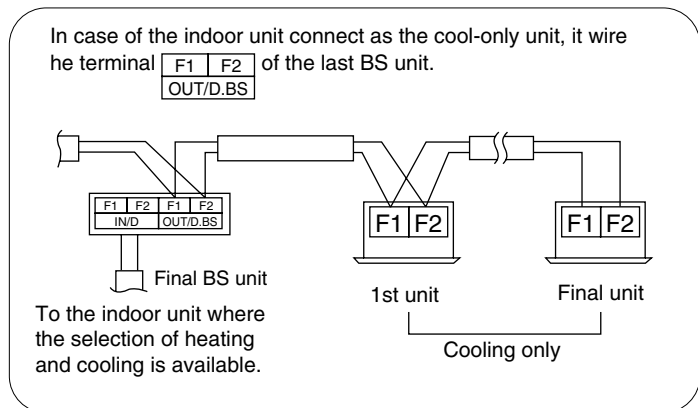

Fig. 1

---

#### 4.4.2.3 Setting of Low Noise Operation and Demand Operation

---

##### Setting of Low Noise Operation

By connecting the external contact input to the low noise input of the outdoor unit external control adapter (optional), you can lower operating noise by 2-3 dB.

##### **A. When the low noise operation is carried out by external instructions (with the use of the outdoor unit external control adapter)**

1. Set "External low noise / Demand YES/NO setting" to "External low noise / Demand YES". (Set by Setting Mode 2)
2. Set "External low noise level setting" on the outdoor unit PC board, as the need arises. (Lower noise operation can be carried out by "Mode 2" than by "Mode 1", and by "Mode 3" than by "Mode 2".)
3. Set "Capacity precedence setting" on the outdoor unit PC board, as the need arises. (If set to "ON", when air conditioning load gets higher, the low noise instructions are neglected to switch to normal operation.) (Set by Setting Mode 2)

##### **B. When the low noise operation is carried out automatically at night (The outdoor unit external control adapter is not required)**

1. Set "Night-time low noise setting" on the outdoor unit PC board. (Set by Setting Mode 2) (Lower noise operation can be carried out by "Mode 2" than by "Mode 1", and by "Mode 3" than by "Mode 2".)
2. Set "Night-time low noise start setting" on the outdoor unit PC board, as the need arises. (Set by Setting Mode 2) (Since the time is presumed in accordance with the outdoor temperature, the starting time is a target only.)
3. Set "Night-time low noise end setting" on the outdoor unit PC board, as the need arises. (Set by Setting Mode 2) (Since the time is presumed in accordance with the outdoor temperature, the ending time is a target only.)
4. Set "Capacity precedence setting" on the outdoor unit PC board, as the need arises. (Set by Setting Mode 2) (If set to "ON", when air conditioning load gets higher, the status is switched to normal operation even at night.)

Image of operation in the case of A

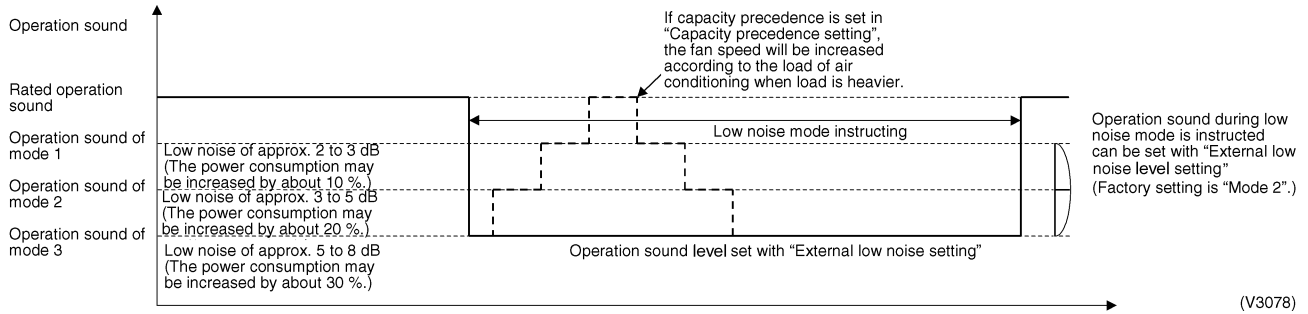

Image of operation in the case of B

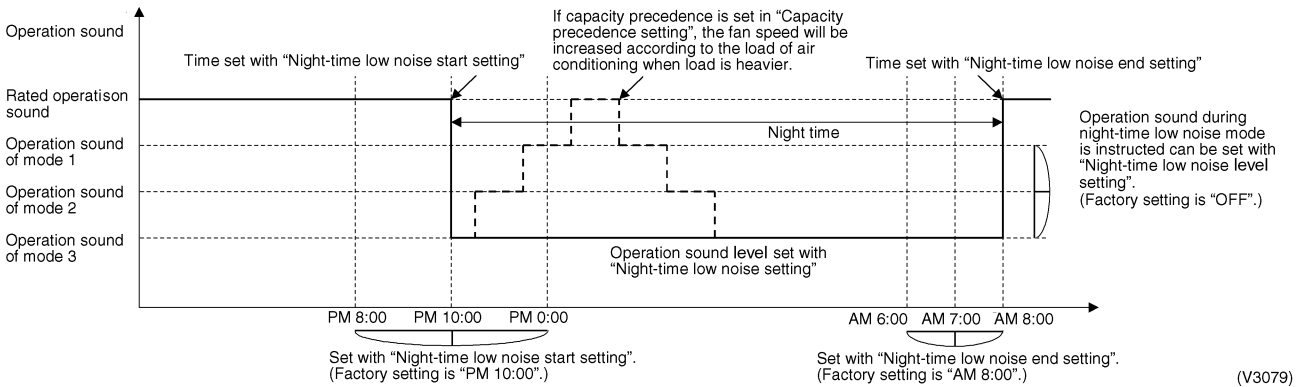
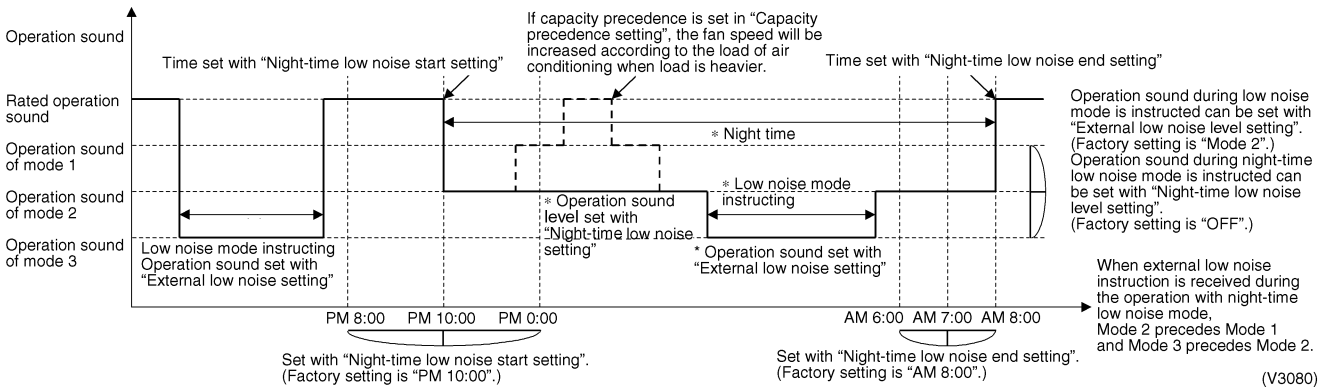

Image of operation in the case of A, B



---

## Setting of Demand Operation

By connecting the external contact input to the demand input of the outdoor unit external control adapter (optional), the power consumption of unit operation can be saved suppressing the compressor operating condition.

### **A. When the demand operation is carried out by external instructions (with the use of the outdoor unit external control adapter).**

- Set the "External low noise/Demand YES/NO setting" switch on the outdoor unit PCB to the "External low noise/Demand YES".  
(Set by Setting Mode 2)
- Set the "Demand 1 level setting " on the outdoor unit PCB, as the need arises.  
(During the demand level 1 instruction, the power consumption can be saved to 80 %, 70 % or 60 % of the rated value respectively.)

### **B. When the continuous demand operation is carried out. (Use of the outdoor unit external control adapter is not required.)**

- Set the "Continuous demand setting" on the outdoor unit PCB.
- If the "Continuous demand setting" is set to the "Continuous demand 1 fixing", set the "Demand 1 setting " on the outdoor unit PCB, as the need arises.  
(During the continuous demand level 1 operation, the power consumption can be saved to 80 %, 70 % or 60 % of the rated value respectively.)

Image of operation in the case of A

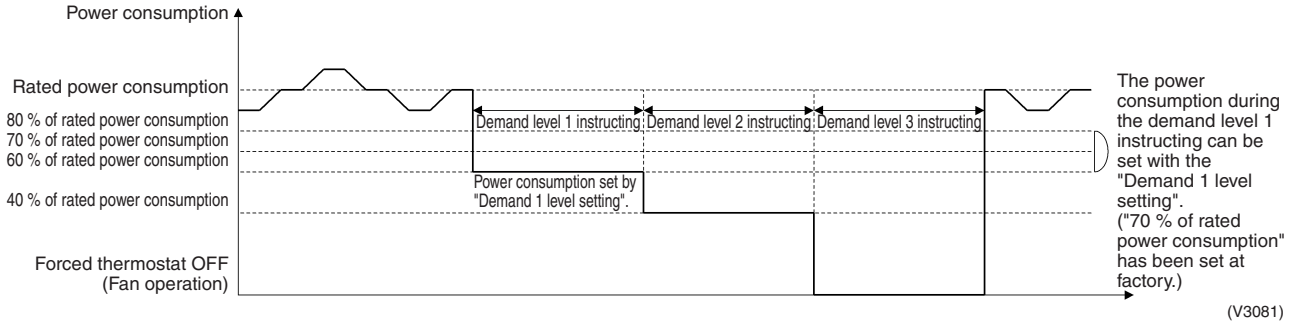

Image of operation in the case of B

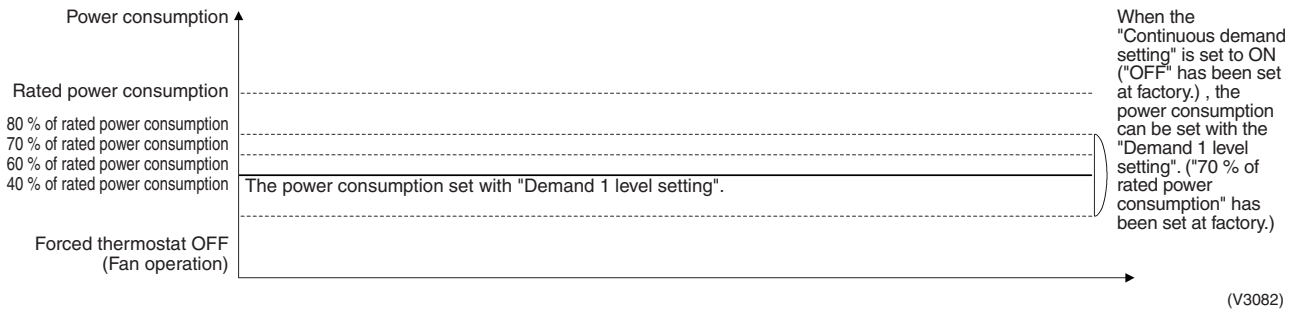
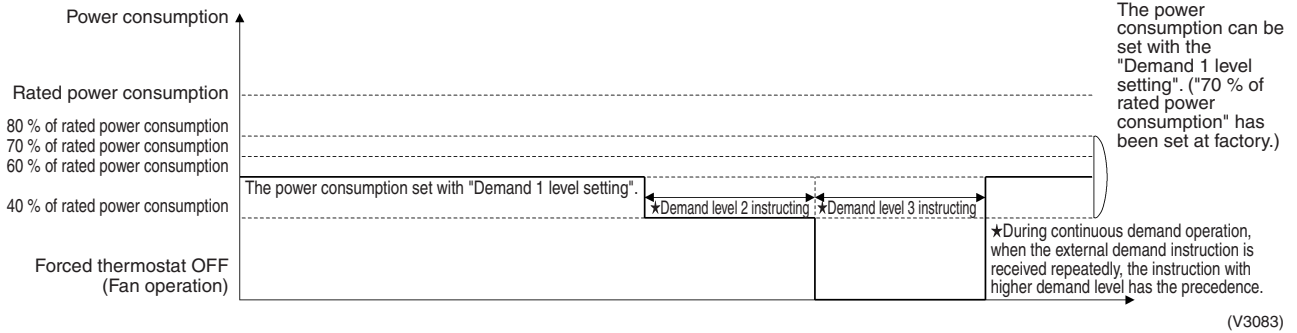

Image of operation in the case of A and B





---

## Detailed Setting Procedure of Low Noise Operation and Demand Control

### 1. Setting mode 1 (H1P off)

- ① In setting mode 2, push the BS1 (MODE button) one time. → Setting mode 2 is entered and H1P lights.  
During the setting mode 1 is displayed, “In low noise operation” and “In demand control” are displayed.

### 2. Setting mode 2 (H1P on)

- ① In setting 1, push and hold the BS1 (MODE button) for more than 5 seconds. → Setting mode 2 is entered and H1P lights.
- ② Push the BS2 (SET button) several times and match the LED display with the Setting No. you want.
- ③ Push the BS3 (RETURN button) one time, and the present setting content is displayed.  
→ Push the BS2 (SET button) several times and match the LED display with the setting content (as shown below) you want.
- ④ Push the BS3 (RETURN button) two times. → Returns to ①.
- ⑤ Push the BS1 (MODE button) one time. → Returns to the setting mode 1 and turns H1P off.

Setting No.	Setting contents	① Setting No. indication							② Setting No. indication							Setting contents	③ Setting contents indication (Initial setting)							
		H1P	H2P	H3P	H4P	H5P	H6P	H7P	H1P	H2P	H3P	H4P	H5P	H6P	H7P		H1P	H2P	H3P	H4P	H5P	H6P	H7P	
22	Night-time low noise setting	○	●	●	●	●	●	●	○	●	○	●	○	●	OFF (Factory setting)	○	●	●	●	●	●	●	●	
															Mode 1	○	●	●	●	●	●	●	◎	●
															Mode 2	○	●	●	●	●	◎	●	●	
															Mode 3	○	●	●	●	●	◎	◎	●	
25	External low noise setting								○	●	○	○	●	●	Mode 1	○	●	●	●	●	●	◎	●	
															Mode 2 (Factory setting)	○	●	●	●	●	◎	●	●	
															Mode 3	○	●	●	●	◎	●	●	●	
26	Night-time low noise start setting								○	●	○	○	●	○	PM 8:00	○	●	●	●	●	●	◎	●	
															PM 10:00 (Factory setting)	○	●	●	●	●	◎	●	●	
															PM 0:00	○	●	●	●	◎	●	●	●	
27	Night-time low noise end setting								○	●	○	○	●	○	AM 6:00	○	●	●	●	●	●	◎	●	
															AM 7:00	○	●	●	●	●	◎	●	●	
															AM 8:00 (Factory setting)	○	●	●	●	◎	●	●	●	
29	Capacity precedence setting								○	●	○	○	○	●	Low noise precedence (Factory setting)	○	●	●	●	●	●	◎	●	
															Capacity precedence	○	●	●	●	●	◎	●	●	
30	Demand setting 1								○	●	○	○	○	○	60 % of rated power consumption	○	●	●	●	●	●	◎	●	
															70 % of rated power consumption (Factory setting)	○	●	●	●	●	◎	●	●	
															80 % of rated power consumption	○	●	●	●	◎	●	●	●	
32	Continuous demand setting								○	●	●	●	●	●	OFF (Factory setting)	○	●	●	●	●	●	◎	●	
															Continuous demand 1 fixed	○	●	●	●	●	◎	●	●	
12	External low noise / Demand setting								○	●	●	○	○	●	NO (Factory set)	○	●	●	●	●	●	○	●	
															YES	○	●	●	●	●	○	●	●	

Setting mode indication section

Setting No. indication section

Set contents indication section

#### 4.4.2.4 Setting of Refrigerant Additional Charging Operation

When additional refrigerant is not charged all with outdoor unit in stop mode, operate the outdoor unit and charge the liquid refrigerant from the service port of liquid stop valve. The additional charging operation is activated by pushbutton switch on the outdoor unit PC board.

##### [Additional refrigerant charge total flow]

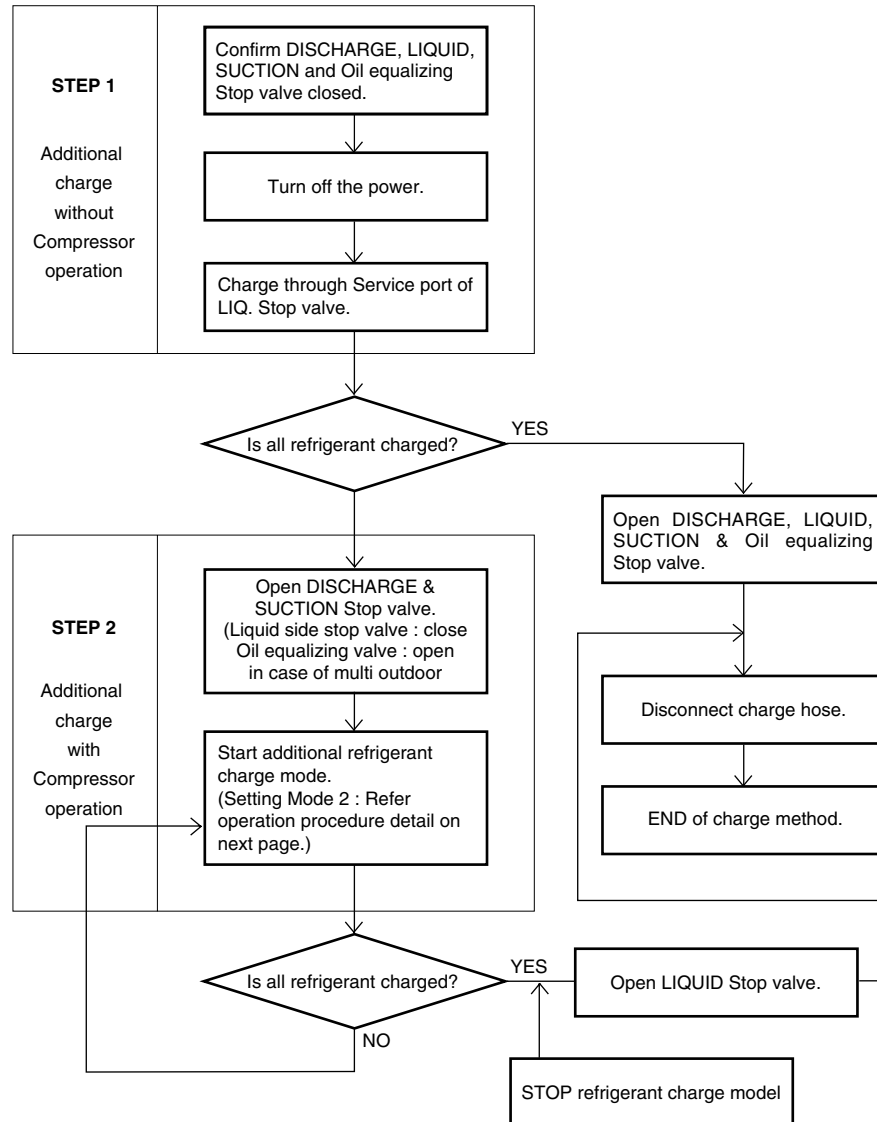

(V2892)

**[Operation procedure detail]**

- ① After turning the respective remote switch of indoor and outdoor units off and charging the refrigerant, turn on the power of indoor and outdoor units.  
Do not fail to turn the power off and charge the refrigerant with outdoor unit in stop mode before adding the refrigerant following this procedure, otherwise resulting in trouble.
- ② Fully open the stop valve on the gas side and oil equalizing valve for multi outdoor connection, and do not fail to fully close the stop valve on the liquid side. (If the stop valve on the liquid side is open, the refrigerant cannot be charged.)
- ③ In **Setting mode 2** (H1P : ON) with outdoor unit in stop mode, Set "A Additional refrigerant charging operation" switch to ON to start the operation. (H2P turns to display TEST OPERATION (blinks), and "TEST OPERATION" and "IN CENTRALIZED CONTROL" are displayed on the remote controller.)
- ④ When the refrigerant is charged up to the specified amount, press the RETURN button (BS3) to stop charging.  
The charging operation is automatically stopped after operating for a maximum of about 30 minutes.  
If the charging is not complete within 30 minutes, set the A Additional refrigerant charging operation again to start charging. When the charging immediately stops even by restarting, the refrigerant is charged excessively. The refrigerant cannot be charged any more.
- ⑤ **Do not fail to fully open the stop valve on the liquid side** as soon as disconnecting the refrigerant charging hose.  
**(The piping may be burst due to the liquid sealing.)**

**[Operation state]**

- Compressor frequency : 210Hz
- Y4S, Y7S, Solenoid valve : Open      Y1E, Y2E electronic expansion valve : 1400 pulse
- Outdoor unit fan : High pressure control
- Indoor unit expansion valve (All unit) : 1024 pulse
- Indoor unit fan : H tap

**4.4.2.5 Setting of Refrigerant Recovery Mode**

When carrying out the refrigerant collection on site, fully open the respective expansion valve of indoor and outdoor units

**[Operation procedure]**

- ① In **setting mode 2** with units in stop mode, set "B Refrigerant Recovery / Vacuuming mode" to ON. The respective expansion valve of indoor and outdoor units are fully opened. (H2P turns to display "TEST OPERATION" (blinks), "TEST OPERATION" and "IN CENTRALIZED CONTROL" are displayed on the remote controller, and the operation is prohibited.
- ② Collect the refrigerant using a refrigerant recovery unit. (See the instruction attached to the refrigerant recovery unit for more detail.)
- ③ Press Mode button "BS1" once and reset "Setting Mode 2".

#### 4.4.2.6 Setting of Vacuuming Mode

In order to perform vacuuming operation at site, fully open the expansion valves of indoor and outdoor units to turn on some solenoid valves.

##### [Operating procedure]

- ① With **Setting Mode 2** while the unit stops, set (B) Refrigerant recovery / Vacuuming mode to ON. The expansion valves of indoor and outdoor units fully open and some of solenoid valves open.  
(H2P blinks to indicate the test operation, and the remote controller displays "Test Operation" and "In Centralized control", thus prohibiting operation.)  
After setting, do not cancel "Setting Mode 2" until completion of Vacuuming operation.
- ② Use the vacuum pump to perform vacuuming operation.
- ③ Press Mode button "BS1" once and reset "Setting Mode 2".

#### 4.4.2.7 Check Operation

To prevent any trouble in the period of installation at site, the system is provided with a test operation mode enabling check for incorrect wiring, stop valve left in closed, coming out (or misplacing with suction pipe thermistor) of discharge pipe thermistor and judgment of piping length, refrigerant overcharging, and learning for the minimum opening degree of motorized valve.

##### CHECK OPERATION FUNCTION

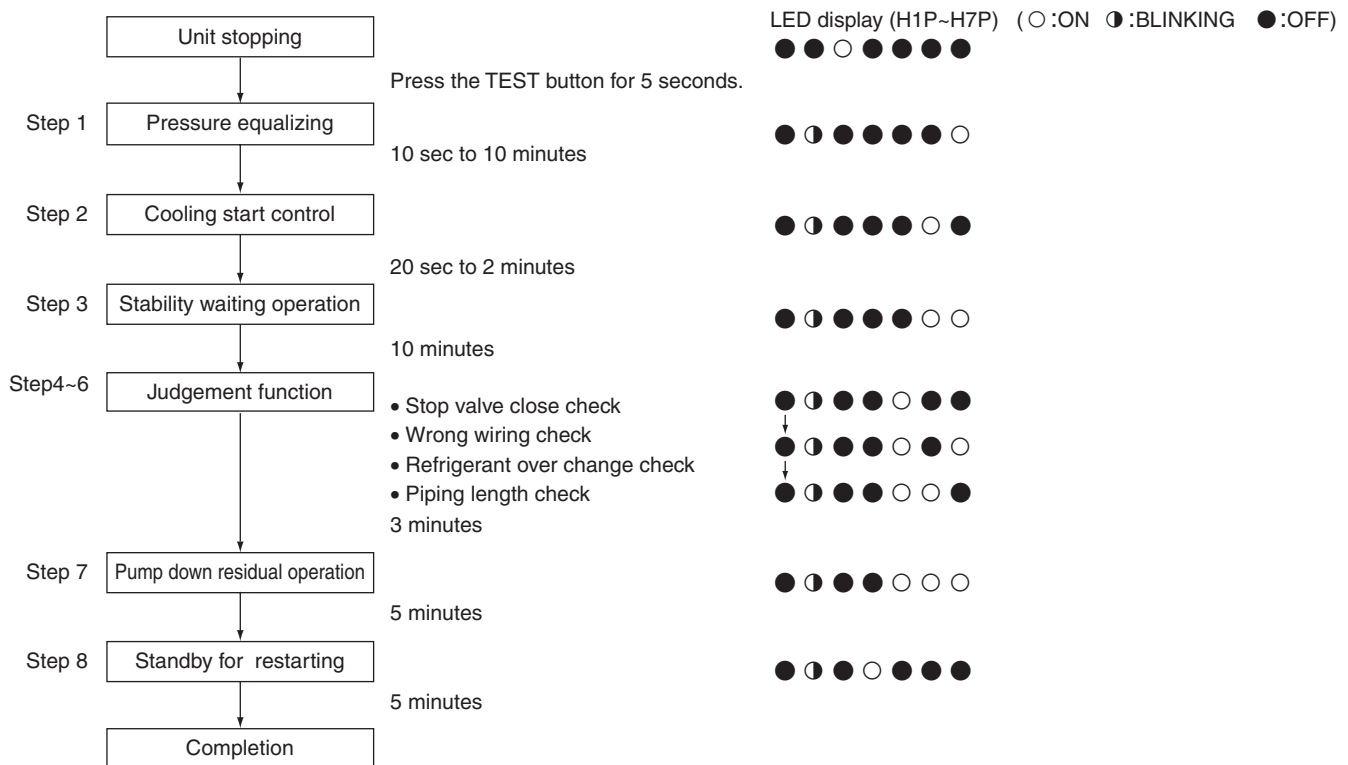

## 5. Caution for Refrigerant Leaks

### 5.1 Caution for Refrigerant Leaks

(Points to note in connection with refrigerant leaks)

#### 5.1.1 Introduction

The installer and system specialist shall secure safety against leakage according to local regulations or standards. The following standards may be applicable if local regulations are not available.

The VRV System, like other air conditioning systems, uses R410A as refrigerant. R410A itself is an entirely safe non-toxic, non-combustible refrigerant. Nevertheless care must be taken to ensure that air conditioning facilities are installed in a room which is sufficiently large. This assures that the maximum concentration level of refrigerant gas is not exceeded, in the unlikely event of major leak in the system and this in accordance to the local applicable regulations and standards.

#### 5.1.2 Maximum concentration level

The maximum charge of refrigerant and the calculation of the maximum concentration of refrigerant is directly related to the humanly occupied space in to which it could leak.

The unit of measurement of the concentration is lb/ft<sup>3</sup> ( the weight in lb. of the refrigerant gas in 1ft<sup>3</sup> volume of the occupied space).

Compliance to the local applicable regulations and standards for the maximum allowable concentration level is required.

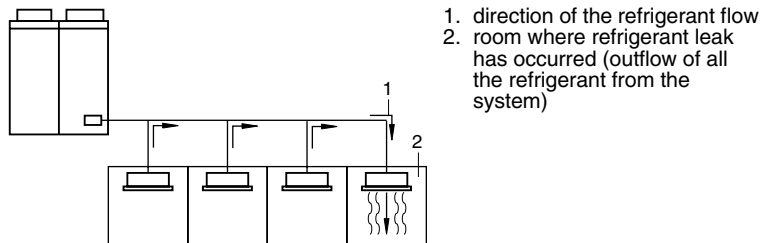

Pay a special attention to the place, such as a basement, etc. where refrigerant can stay, since refrigerant is heavier than air.

#### 5.1.3 Procedure for checking maximum concentration

Check the maximum concentration level in accordance with steps 1 to 4 below and take whatever action is necessary to comply.

1. Calculate the amount of refrigerant (lb.) charged to each system separately.

amount of refrigerant in a single unit system (amount of refrigerant with which the system is charged before leaving the factory)	+	additional charging amount (amount of refrigerant added locally in accordance with the length or diameter of the refrigerant piping)	=	total amount of refrigerant (lb.) in the system
---	---	--	---	---



**Note:**

- Where a single refrigerant facility is divided into 2 entirely independent refrigerant systems then use the amount of refrigerant with which each separate system is charged.
2. Calculate the smallest room volume (ft<sup>3</sup>)  
In case like the following, calculate the volume of (A), (B) as a single room or as the smallest room.

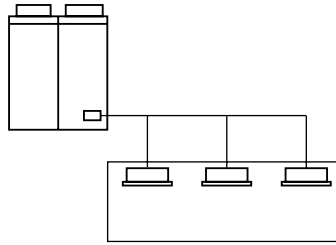
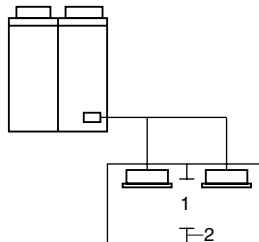
**A.** Where there are no smaller room divisions**B.** Where there is a room division but there is an opening between the rooms sufficiently large to permit a free flow of air back and forth.

1. opening between rooms
2. partition

(Where there is an opening without a door or where there are openings above and below the door which are each equivalent in size to 0.15% or more of the floor area.)

**3.** Calculating the refrigerant density using the results of the calculations in steps 1 and 2 above.

$$\frac{\text{total volume of refrigerant in the refrigerant system}}{\text{size (ft}^3\text{) of smallest room in which there is an indoor unit installed}} \leq \text{maximum concentration level (lb./ft}^3\text{)}$$

If the result of the above calculation exceeds the maximum concentration level then make similar calculations for the second then third smallest room and so until the result falls short of the maximum concentration.

**4.** Dealing with the situations where the result exceeds the maximum concentration level.

Where the installation of a facility results in a concentration in excess of the maximum concentration level then it will be necessary to revise the system.

Please consult your Daikin supplier.

## 6. Hand Over to Customer

### 6.1 Operational Steps

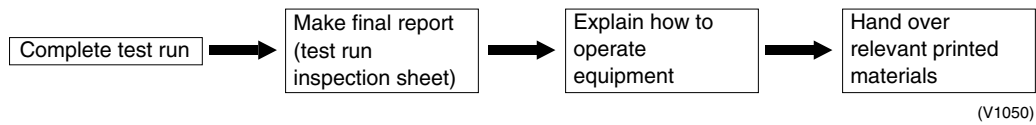

#### Important Points

- The measurements taken during the test run should be recorded and kept on a test run inspection sheet.
- Do not forget to record the **length of the refrigerant piping** and the **refrigerant additional charging volume** on the plate on the back of the outdoor unit external notice board, as this information will be required for servicing the system.
- Explain to the customer how to operate the equipment and let him try it.
- Assemble all the relevant diagrams and other printed matter which is required to operate the system and hand it all over to the customer (on the spot) and tell him to keep it.

List of equipment which has been delivered

Contract drawings

It is essential to prepare a control wiring diagram which clarifies the refrigerant system and the control system.

1 set of operation manuals

Names of those responsible for the work (emergency contact address)

Equipment guarantees.

(V1143)

- Make the service contact address clear.

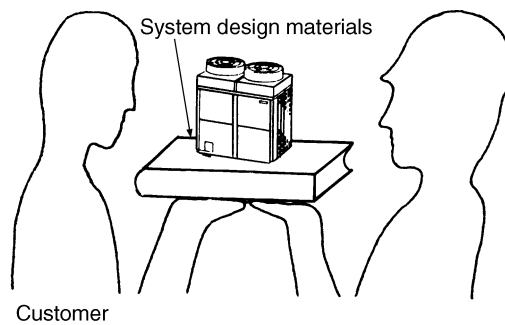



## 7. Appendix

### 7.1 Operating Noise of Indoor Units

#### 7.1.1 Difference between Catalogue Data and Actual Noise

Operating noise differs depending on the place of measurement (room) because of the various degrees with which the room reverberates the sound. To determine the amount of reverberation under uniform conditions, the unit has been measured in a dead room with results having been compiled in the below table. The actual sound produced in unit operation can be determined from Table 1.

Sound pressure rise due to room reverberation (Higher than catalogue data)

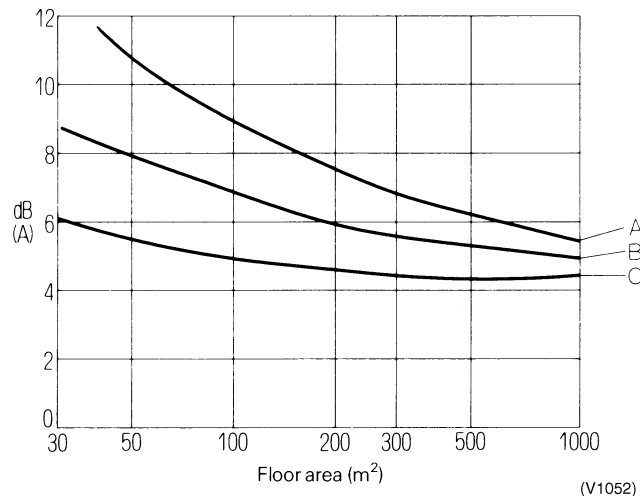

Table 1

		A	B	C
Room Interior Detection	Floor	Mortar	Linoleum tile	Carpet
	Walls	Mortar	Plaster	Fiberglass + Saroncross finish
	Ceiling	Mortar	mineral wool tile	Fiberglass + Saroncross finish
Average Absorbed Sound (Room with Approx. 50 m <sup>2</sup> Floor Area)		0.05	0.12	0.25
		Typical office		
Estimated value to be added to catalogue value		11~12	8~8.5	5~6

#### Classifications of indoor unit environments (reference data)

Table 2

Classification	Environment	Example	Faint Noises (NOTE 2)	Recommended Operating Noise on Site
1	Non-active places requiring silence	Reception rooms, libraries, sitting rooms, hospitals (examining rooms) (NOTE 1)	~35	~40
2	Sedate business activities that do not disturb people even over time	Quiet offices, classrooms, small conference rooms, lobbies	~40	~45
3	Somewhat quiet settings that permit soft-spoken conversation, typical activities	Small offices, large conferences rooms, quiet stores, restaurants	~45	~50
4	Somewhat loud settings that permit regular conversation, brisk activity	Large offices, typical stores, cafeterias	~50	~55
5	Loud places that permit conversation in a loud voice, highly active place with many people	Loud large-side offices, large cafeterias, loud stores	~55	~60
6	Rather loud settings	Factories, gymnasiums, recreational places like pachinko parlors	~60	~65



**Note:**

1. Excluding bedrooms
2. Reference values of faint noises in the place of usage

### 7.1.2 Faint Noises and Correcting Operating Noise with Respect to Faint Noises

Faint noises are defined as peripheral sounds existing while the unit is not running, which are picked up when measuring operating noise. If these faint noises are 10 dB or more than the noise produced by the unit, the measured value can be taken as the operating noise of the unit. But, the difference must be corrected if less than 10 dB, because of the effect these noises have on the actual measured value. Also, when the sound meter remains unchanged even while the unit is stopped, we can determine the operational noise to be at least 10 dB less than the faint noises, but we cannot pinpoint the operating noise exactly.

For example, if the faint noises are some 65 dB and the noise produced by the unit in operation is 70 dB, the indicated difference comes to 5 dB. Using Table 3, we recommend you correct the operating noise by about 2 dB to 68 dB.

Table 3 Correcting the effect of faint noises

Unit: dB

Difference between when noise is produced and when not	1	2	3	4	5	6	7	8	9	10
Corrective Value	-6.9	-4.4	-3.0	-2.3	-1.7	-1.25	-0.95	-0.75	-0.60	-0.45

### 7.1.3 Calculating Operating Noise

When two or more units are running at the same time, the amount of operating noise they produce rises. The total amount of noise produced can be obtained ahead of time with Chart 4.

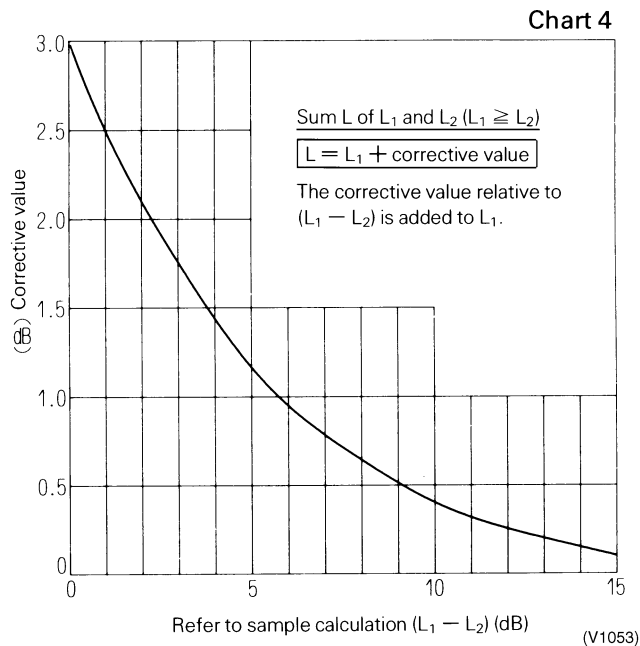

**Sample calculation 1**

$L_1$  and  $L_2$  are given as compounded sounds of 50 and 49 dB respectively. Since  $L_1 - L_2 = 50 - 49 = 1$ , the corrective value is 2.5, therefore  $50 + 2.5 = 52.5$  dB.

**Sample calculation 2**

When sounds of 40 dB, 38 dB, 37 dB and 40 dB are placed in order of magnitude, we obtain the following:

40 dB, 40 dB, 38 dB, 37 dB

To start, the difference between 40 dB and 40 dB is 0, therefore we take a corrective value of 3dB and obtain  $40 + 3 = 43$  dB. The compounded sound of 43 dB and 38 dB has a 5.0 dB difference, thus a corrective value of 1.2 dB, which gives us 44.2 dB from  $43 + 1.2$ . In the same manner, the corrective value for 44.2 dB and 37 dB is approximately 0.7 dB, or in other words,  $44.2 + 0.7 = 44.9$  dB.

## 7.2 Allowable Piping Length

### 7.2.1 Branch with refnet joint

(Connection of 8 indoor units Heat pump system)

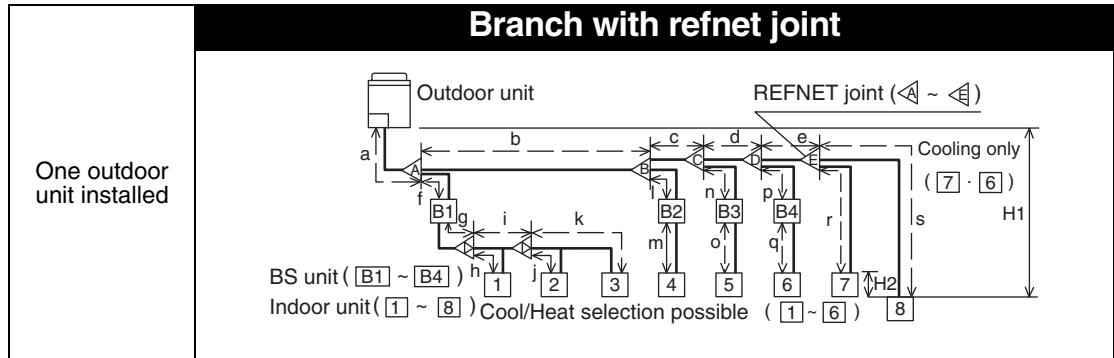

#### Maximum allowable length

Between outdoor and indoor units

- Actual pipe length  
Pipe length between outdoor and indoor units  $\leq 330\text{ft.}$   
Example unit 8:  $a + b + c + d + e + s \leq 330\text{ft.}$
- Equivalent length  
Equivalent pipe length between outdoor and indoor units  $\leq 390\text{ft.}$   
(assume equivalent pipe length of refnet joint to be 1.6ft., that of refnet header to be 3.3ft., calculation purposes)
- Total extension length  
Total piping length from outdoor unit\* to all indoor units  $\leq 950\text{ft.}$

#### Allowable height length

Between outdoor and indoor units

- Difference in height  
Difference in height between outdoor and indoor units ( $H1$ )  $\leq 164\text{ft.}$   
(Max 130ft. if the outdoor unit is below)

Between indoor and indoor units

- Difference in height  
Difference in height between adjacent indoor units ( $H2$ )  $\leq 49\text{ft.}$

#### Allowable length after the branch

- Actual pipe length

Pipe length from first refrigerant branch kit (either refnet joint or refnet header) to indoor unit  $\leq 130\text{ft.}$   
Example unit 8:  $b + c + d + e + s \leq 130\text{ft.}$

## 7.2.2 Branch with refnet joint and refnet header

(Connection of 8 indoor units Heat pump system)

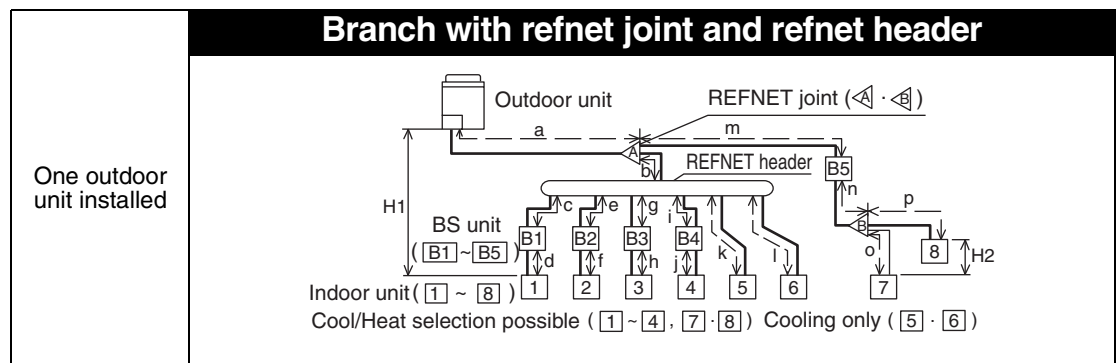

### Maximum allowable length

Between outdoor and indoor units

- Actual pipe length  
Pipe length between outdoor and indoor units  $\leq 330\text{ft.}$   
Example unit 6:  $a + b + i \leq 330\text{ft.}$ , unit 8:  $a + m + n + p \leq 330\text{ft.}$
- Equivalent length  
Equivalent pipe length between outdoor and indoor units  $\leq 390\text{ft.}$   
(assume equivalent pipe length of refnet joint to be 1.6ft., that of refnet header to be 3.3ft., calculation purposes)
- Total extension length  
Total piping length from outdoor unit\* to all indoor units  $\leq 950\text{ft.}$

### Allowable height length

Between outdoor and indoor units

- Difference in height  
Difference in height between outdoor and indoor units ( $H1$ )  $\leq 164\text{ft.}$   
(Max 130ft. if the outdoor unit is below)

Between indoor and indoor units

- Difference in height  
Difference in height between adjacent indoor units ( $H2$ )  $\leq 49\text{ft.}$

### Allowable length after the branch

- Actual pipe length  
Pipe length from first refrigerant branch kit (either refnet joint or refnet header) to indoor unit  $\leq 130\text{ft.}$   
Example unit 6:  $b + i \leq 130\text{ft.}$ , unit 8:  $m + n + p \leq 130\text{ft.}$

## 7.2.3 Branch with refnet header

(Connection of 8 indoor units Heat pump system)

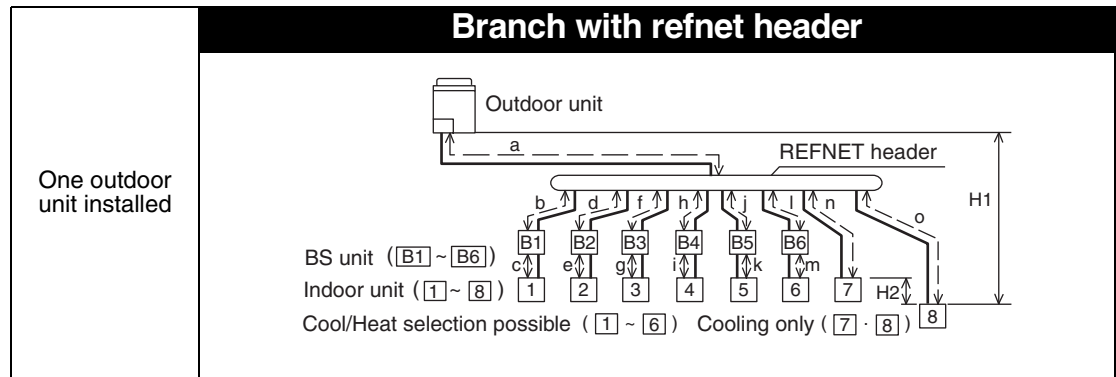

### Maximum allowable length

Between outdoor and indoor units

- Actual pipe length  
Pipe length between outdoor and indoor units  $\leq 330\text{ft.}$   
Example unit 6:  $a + o \leq 330\text{ft.}$
- Equivalent length  
Equivalent pipe length between outdoor and indoor units  $\leq 390\text{ft.}$   
(assume equivalent pipe length of refnet joint to be 1.6ft., that of refnet header to be 3.3ft., calculation purposes)
- Total extension length  
Total piping length from outdoor unit\* to all indoor units  $\leq 950\text{ft.}$

### Allowable height length

Between outdoor and indoor units

- Difference in height  
Difference in height between outdoor and indoor units ( $H1$ )  $\leq 164\text{ft.}$   
(Max 130ft. if the outdoor unit is below)

Between indoor and indoor units

- Difference in height  
Difference in height between adjacent indoor units ( $H2$ )  $\leq 49\text{ft.}$

### Allowable length after the branch

- Actual pipe length

Pipe length from first refrigerant branch kit (either refnet joint or refnet header) to indoor unit  $\leq 130\text{ft.}$   
Example unit 8:  $o \leq 130\text{ft.}$

## 7.3 Refrigerant branch kit selection

Refrigerant branch kits can only be used with R410A.

### 7.3.1 How to select the refnet joint

- When using refnet joints at the first branch counted from the outdoor unit side. Choose from the following table in accordance with the capacity of the outdoor unit.

Outdoor unit capacity type	Refrigerant branch kit name
REYQ 96M type	KHRP26M33T

- For refnet joints other than the first branch, select the proper branch kit model based on the total capacity index of downstream indoor units.

Indoor capacity index	Refrigerant branch kit name	
	in case of 3 pipes	in case of 2 pipes
< 72	KHRP25M22T	KHRP26M22T
72 ≤	KHRP25M33T	KHRP26M33T

\*Example of downstream indoor units

- example in case of refnet joint C; indoor units 5 + 6 + 7 + 8,

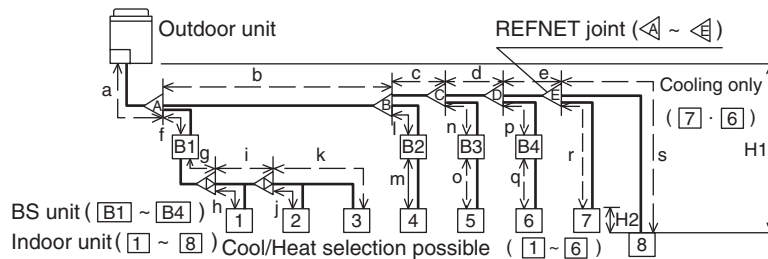

- example in case of refnet joint B indoor units 7 + 8  
example in case of refnet joint header; indoor units 1 + 2 + 3 + 4 + 5 + 6

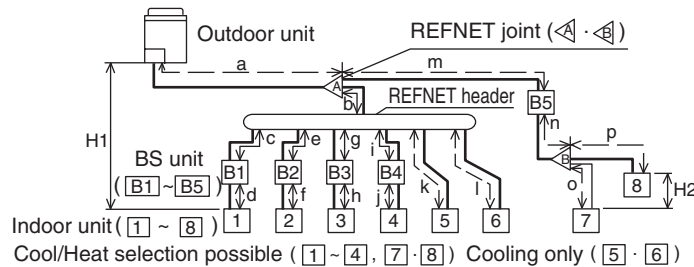

- example in the case of refnet header; indoor units 1 + 2 + 3 + 4 + 5 + 6 + 7 + 8

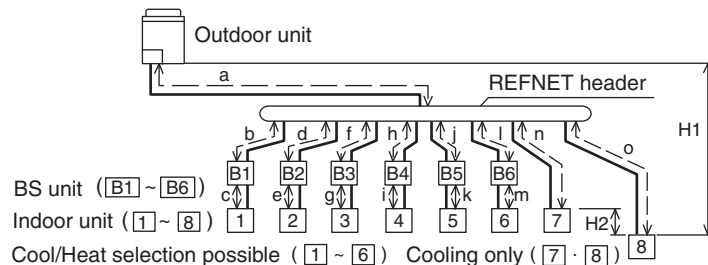

### 7.3.2 How to select the refnet header

- Choose from the following table in accordance with the total capacity of all the indoor units connected below the REFNET header.

Indoor capacity index	Refrigerant branch kit name	
	in case of 3 pipes	In case of 2 pipes
< 72	KHRP25M33H	KHRP26M22H or KHRP26M33H
72 ≤		KHRP26M33H

\*Example of downstream indoor units

- example in case of refnet joint C; indoor units 5 + 6 + 7 + 8

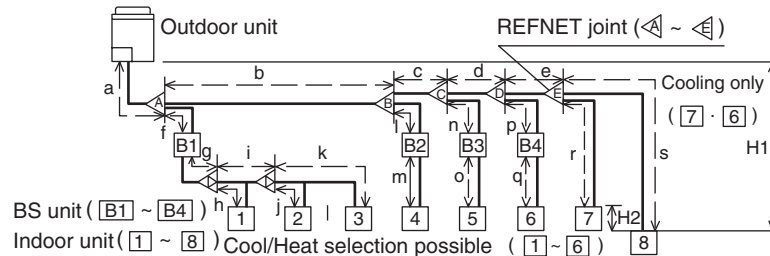

- example in case of refnet joint B indoor units 7 + 8,  
example in case of refnet header; indoor units 1 + 2 + 3 + 4 + 5 + 6

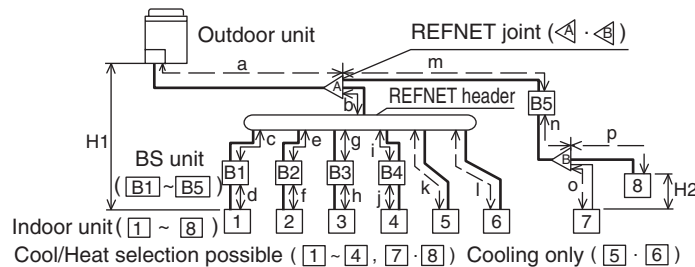

- example in the case of refnet header; indoor units 1 + 2 + 3 + 4 + 5 + 6 + 7 + 8

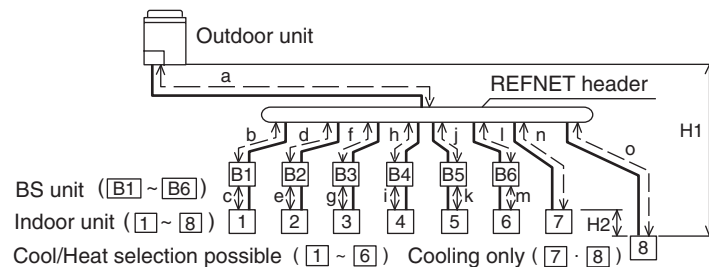

## 7.4 Pipe size selection

Piping between outdoor unit and refrigerant branch kit

- Match to the size of the connection piping on the outdoor unit.

(Unit:in.)

Outdoor unit capacity type	Piping size (outer diameter)		
	Liquid pipe	Gas pipe	
		Suction	Discharge
REYQ96 type	φ3/8	φ7/8	φ3/4

Between two immediately adjacent refrigerant branch kits and BS unit

- Choose from the following table in accordance with the total capacity of all the indoor units connected below this.
- Do not let the connection piping exceed the refrigerant piping size chosen by general system model name.

(Unit:in.)

Indoor capacity Index	Piping size (outer diameter)		
	Liquid pipe	Gas pipe	
		Suction	Discharge
*1 < 24	φ1/4	φ1/2	φ3/8
*2 24 ≤ x < 72	φ3/8	φ5/8	φ1/2
72		φ7/8	φ3/4

Between BS unit (refrigerant branch kit) and indoor unit

- Pipe size for direct connection to indoor unit must be the same as the connection size of indoor unit.

(Unit:in.)

Indoor capacity type	Piping sizes (outer diameter)	
	Gas pipe	Liquid pipe
*1 12, 18 type	1/2	1/4
24, 30, 36, 48 type	5/8	3/8

\*1 The BS unit (BSVQ36MVJU) port and connection pipe are different sizes. Use the reducing joints included with the BS unit.

\*2 When the indoor capacity is  $60 \leq x < 72$ , use the attached pipes included with BS unit.



## 7.5 How to calculate the additional refrigerant to be charged

Additional refrigerant to be charged R (lb.)  
R should be rounded off in units of 0.1lb..



**Note:** If a negative result is gotten for R from the formula at right, no refrigerant needs to be added.

$$R = \left( \text{Total length (ft.) of liquid piping size at } \phi 1/2'' \right) \times 0.074 + \left( \text{Total length (ft.) of liquid piping size at } \phi 3/8'' \right) \times 0.036 + \left( \text{Total length (ft.) of liquid piping size at } \phi 1/4'' \right) \times 0.015$$

\*Example for refrigerant branch using refnet joint and refnet header

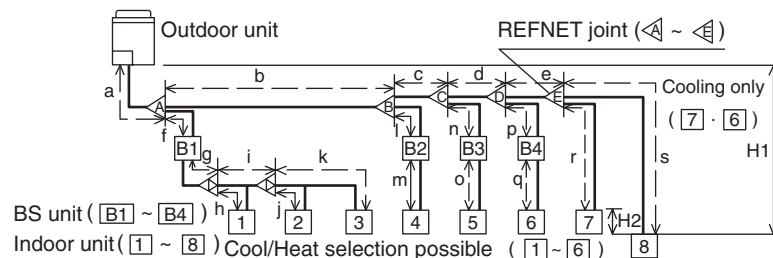

\*Example for refrigerant branch using refnet joint and refnet header

If the piping lengths are as at right

a: $\phi 3/8 \times 100\text{ft.}$	d: $\phi 1/4 \times 30\text{ft.}$	g: $\phi 1/4 \times 30\text{ft.}$	j: $\phi 1/4 \times 30\text{ft.}$
b: $\phi 3/8 \times 30\text{ft.}$	e: $\phi 1/4 \times 30\text{ft.}$	h: $\phi 1/4 \times 70\text{ft.}$	k: $\phi 1/4 \times 25\text{ft.}$
c: $\phi 1/4 \times 30\text{ft.}$	f: $\phi 1/4 \times 30\text{ft.}$	i: $\phi 3/8 \times 30\text{ft.}$	

$$R = \{ [a+b+i \times 0.036] + [c+d+e+f+g+h+j+k \times 0.015] \} \times 1.15 = 11.37 \Rightarrow [11.4]$$



**Note:** The amount of refrigerant to be added to the unit should be written on the included "Added Refrigerant" plate and attached to the rear side of the front cover. Refer next page.

REQUEST FOR THE INDICATION OF ADDITIONAL REFRIGERANT CHARGING AMOUNT AND INSTALLATION DATE

BE SURE TO FILL THE BLANKS, WHICH ARE NEEDED FOR AFTER-SALE SERVICES,

1. CALCULATION OF ADDITIONAL REFRIGERANT CHARGING AMOUNT

- CALCULATE THE ADDITIONAL REFRIGERANT CHARGING AMOUNT BASED ON THE FORMULAE BELOW BEFORE REFRIGERANT SUPPLY OR CHARGING.
- WHEN RE-CHARGING TOTAL AMOUNT OF REFRIGERANT, CHARGE THE TOTAL OF THE AMOUNT CHARGED AT SHIPMENT (INDICATED ON THE MACHINE NAMEPLATE) AND THE ADDITIONAL AMOUNT SHOWN AS FOLLOWS :

OUTDOOR UNIT

$$\begin{array}{|c|} \hline \text{ADDITIONAL CHARGING} \\ \text{AMOUNT} \\ \hline \text{lb.} \\ \hline \end{array} = \left( \begin{array}{|c|} \hline \text{TOTAL LENGTH OF LIQUID} \\ \text{PIPE SIZE } \phi 1/2 \times 0,074 \\ \hline \text{(ft)} \times 0,074 \\ \hline \end{array} + \begin{array}{|c|} \hline \text{TOTAL LENGTH OF LIQUID} \\ \text{PIPE SIZE } \phi 3/8 \times 0,036 \\ \hline \text{(ft)} \times 0,036 \\ \hline \end{array} + \begin{array}{|c|} \hline \text{TOTAL LENGTH OF LIQUID} \\ \text{PIPE SIZE } \phi 1/4 \times 0,015 \\ \hline \text{(ft)} \times 0,015 \\ \hline \end{array} \right) \times \Delta$$

OUTDOOR UNIT	
MODEL NAME	Δ
RXYQ96M	1
REYQ96M	1,15

2. RECORD OF INDOOR UNIT MODEL NAME AND INSTALLATION SITE

NO.	1	2	3	4	5
MODEL NAME					
INSTALLATION SITE					
NO.	6	7	8	9	10
MODEL NAME					
INSTALLATION SITE					

3. RECORD OF INSTALLATION DATE      DA      ,      MO      ,      YR

4. AFTER EQUIPPING, PLEASE ATTACH IT TO THE REAR SIDE OF THE FRONT COVER.

3P135887-1

## 7.6 REFNET Pipe Connections for VRV R410A Series

### 7.6.1 REFNET Joint (Branch Kit)

#### KHRP26M22T

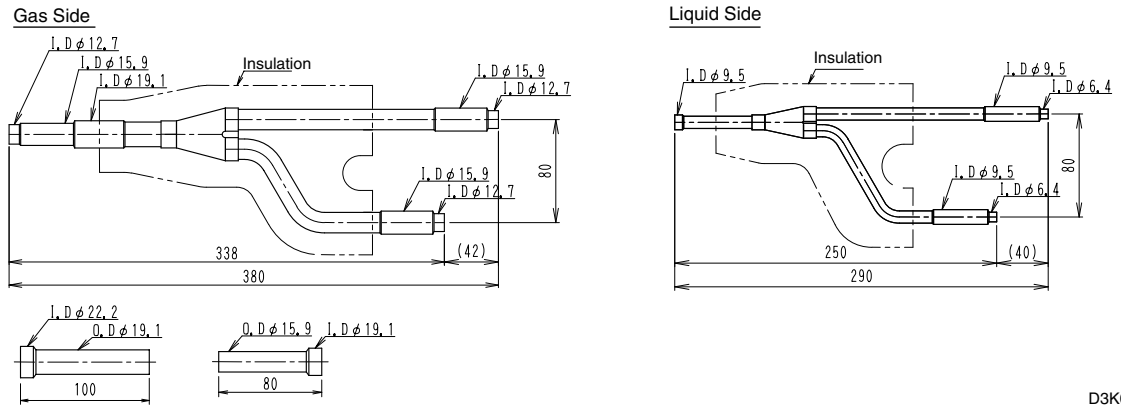

#### KHRP26M33T

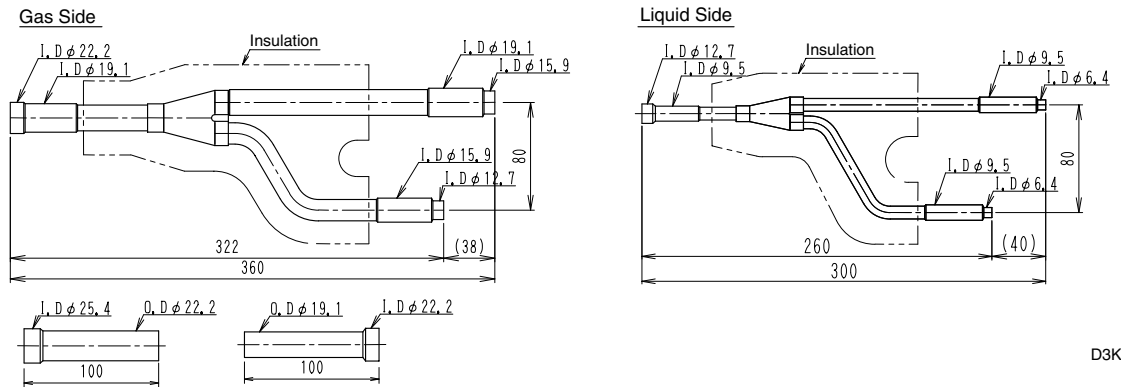

**KHRP25M22T**

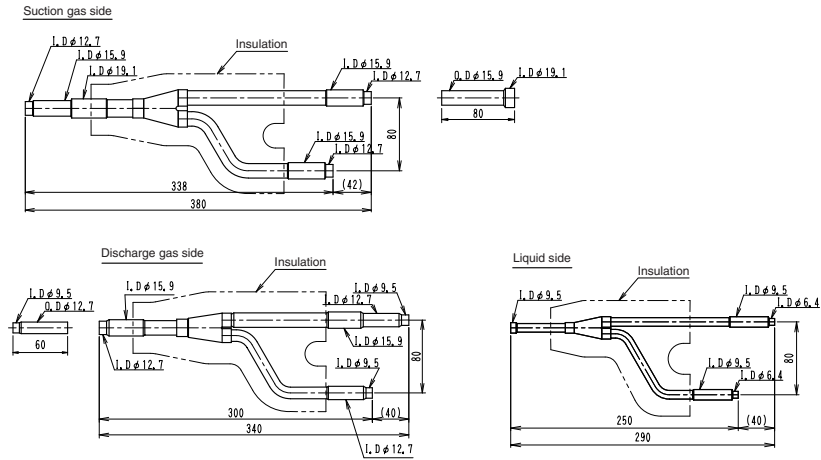

D3K03626A

**KHRP25M33T**

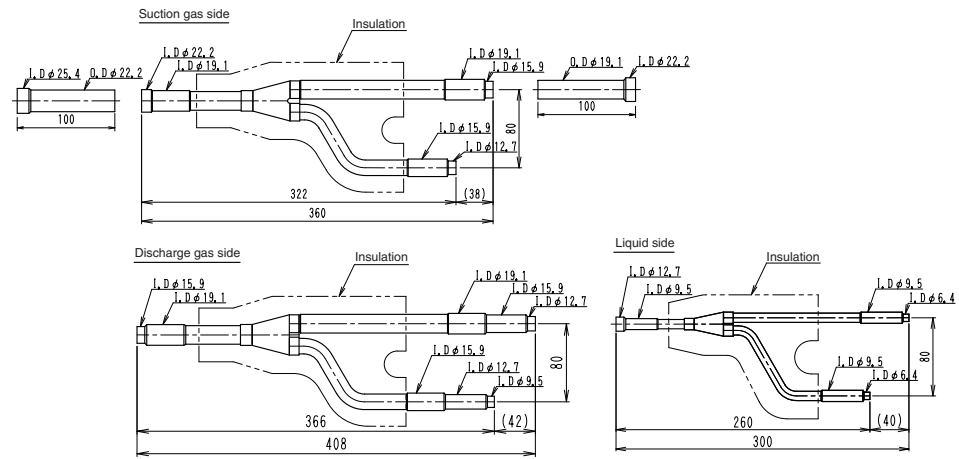

D3K03627B

## 7.6.2 REFNET Header (Branch Kit)

### KHRP26M22H

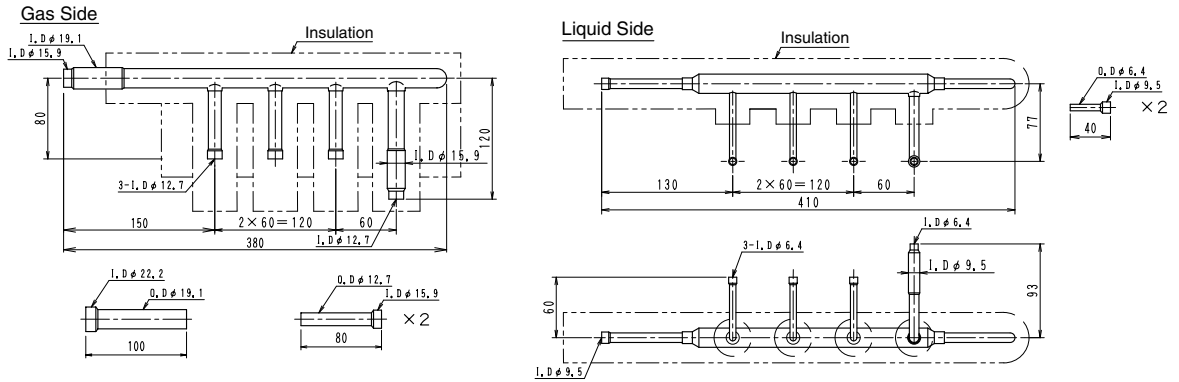

D3K03629B

### KHRP26M33H

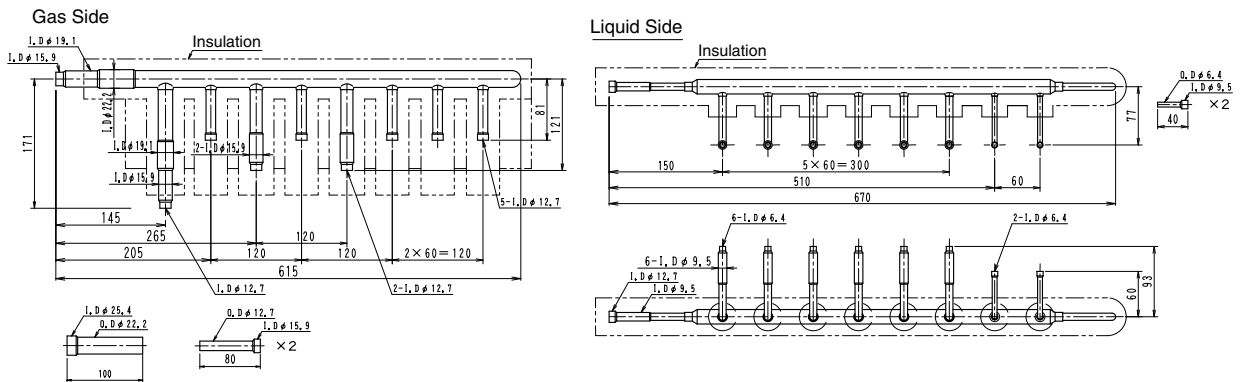

D3K03630B

### KHRP25M33H

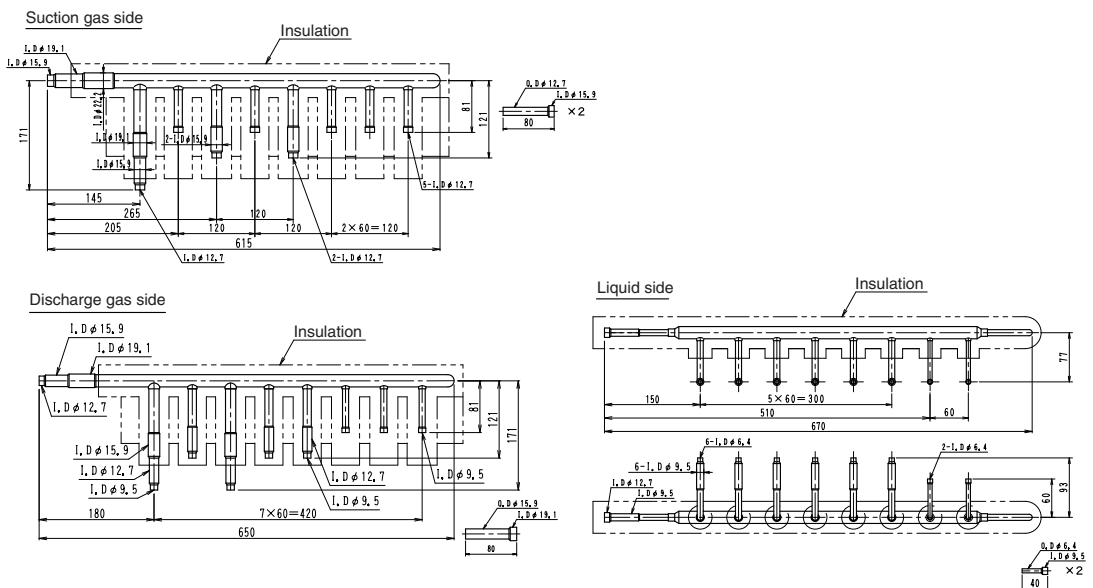

D3K03633B

### 1. REFNET Joints

For gas and liquid branch pipes

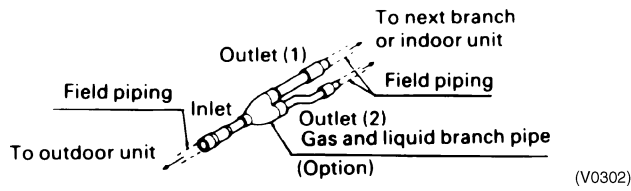

- Make sure that all branch pipes are fitted such that they branch either horizontally or vertically.

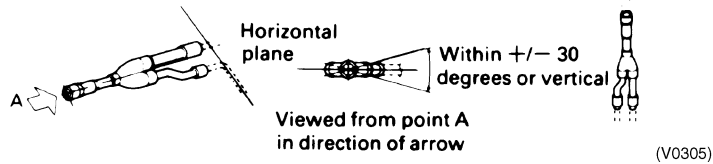

- When the size of the selected field piping is different from that of branch pipe then the connecting section should be cut with a pipe cutter as shown in the figure below.

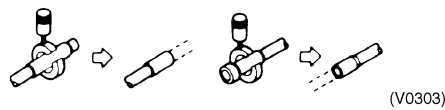

- When you are cutting an inlet or outlet pipe with a pipe cutter make sure that you make the cut in the center of the connection area.

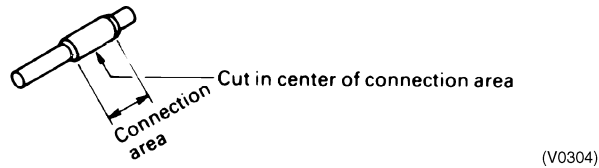

- Branch pipes must be insulated in accordance with the handbook which comes with each kit.

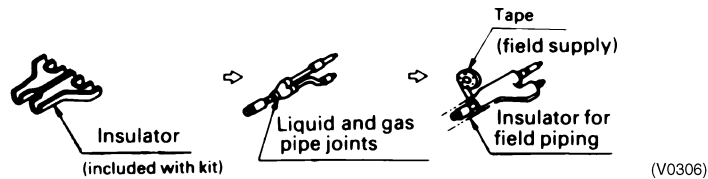

### 2. REFNET Header

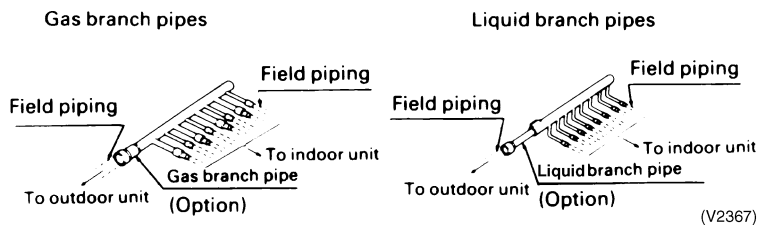

- When the number of indoor units to be connected to the branch pipes is less than the number of branch pipes available for connection then cap pipes should be fitted to the surplus branches.

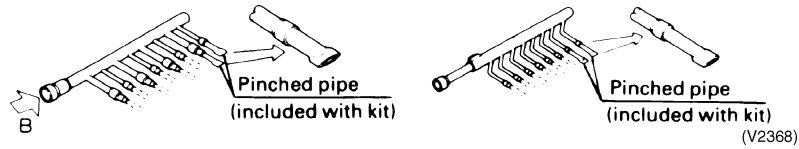

- When the size of the selected field piping is different from that of branch pipe then the connecting section should be cut with a pipe cutter as shown in the figure below.

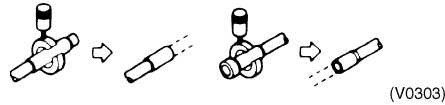

- When field piping is connected to the B section of the inlet/outlet pipe on the outdoor unit side of the liquid pipe header.
- Cut the B section with a pipe cutter as shown below and connect it to the A section.
- Connect the flared section of the field pipe to the B section.

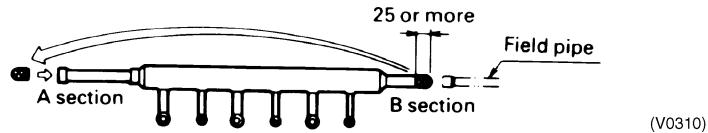

- Fit the branch pipe so that the branch lies in a horizontal plane.

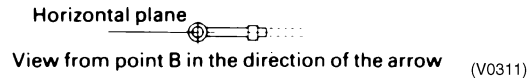

- The branch pipe must be insulated in accordance with the instruction manual which comes with each kit.

1. Use the insulator included in the kit to insulate the header.

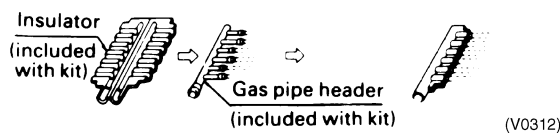

2. Joints between insulators included in the kit and those already applied to the field piping should be sealed with the tape which is also included in each kit.

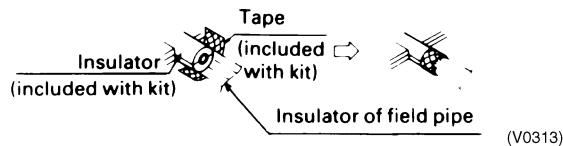

3. Any cap pipes should also be insulated using the insulator provided with each kit and then taped as described above.

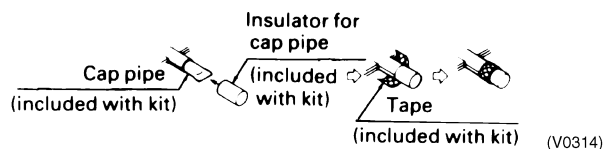

# 7.7 VRV Inspection Sheet

1/6

Inspection date: \_\_\_\_\_

Delivery date: \_\_\_\_\_

Transfer date: \_\_\_\_\_

Owner	System name
-------	-------------

Outdoor units

	Installation location	Model	Unit No.
Outdoor unit system name			

BS Unit and Indoor Unit

BS Unit					Indoor Unit				
No.	Installation	Model	Unit No.	Cool/Heat selector	No.	Installation	Model	Unit No.	Group No.
					1				
					2				
					3				
					4				
					5				
					6				
					7				
					8				
					9				
					10				

Field settings

Low noise operation			Sequential start						
ON	OFF		ON	OFF					
Tc			Te			Defrost SETTING			Refrigerant addition/replenishment
H	M	L	H	M	L	H	M	L	kg

Company name \_\_\_\_\_

Inspector \_\_\_\_\_

(V1091)



Before turning on the power

System name \_\_\_\_\_

	Inspection item	Inspection method	Standard (guideline)	Measurement values				Decision	
				G		NG			
	Breaker capacity	Visual inspection	Specified capacity	G		NG			
Outdoor unit	Refrigerant piping system	Gas detector	No leaks	G		NG			
	Heat exchanger	Visual inspection	No clogging or damage	G		NG			
	Terminal connection section	Screwdriver, etc.	No looseness	G		NG			
	Fan motor electrical insulation	500-V megatester	1 MΩ or more					MΩ	
	Compressor electrical insulation	500-V megatester	1 MΩ or more	INV	MΩ	STD1	MΩ	STD2	MΩ
	Installation	Visual inspection	Short circuit, etc.	G		NG			
Indoor unit	Refrigerant system	Gas detector	No leaks	Room 1	G	NG	Room 6	G	NG
				Room 2	G	NG	Room 7	G	NG
				Room 3	G	NG	Room 8	G	NG
				Room 4	G	NG	Room 9	G	NG
				Room 5	G	NG	Room 10	G	NG
	Air filter	Visual inspection	No clogging or damage	Room 1	G	NG	Room 6	G	NG
				Room 2	G	NG	Room 7	G	NG
				Room 3	G	NG	Room 8	G	NG
				Room 4	G	NG	Room 9	G	NG
				Room 5	G	NG	Room 10	G	NG
	Heat exchanger	Visual inspection	No clogging or damage	Room 1	G	NG	Room 6	G	NG
				Room 2	G	NG	Room 7	G	NG
				Room 3	G	NG	Room 8	G	NG
				Room 4	G	NG	Room 9	G	NG
				Room 5	G	NG	Room 10	G	NG
	Fan motor electrical insulation	500-V megatester	1 MΩ or more	Room 1	G	NG	Room 6	G	NG
				Room 2	G	NG	Room 7	G	NG
				Room 3	G	NG	Room 8	G	NG
				Room 4	G	NG	Room 9	G	NG
				Room 5	G	NG	Room 10	G	NG
	Auxiliary heater electrical insulation	500-V megatester	1 MΩ or more	Room 1	G	NG	Room 6	G	NG
				Room 2	G	NG	Room 7	G	NG
				Room 3	G	NG	Room 8	G	NG
				Room 4	G	NG	Room 9	G	NG
				Room 5	G	NG	Room 10	G	NG
Installation	Visual inspection	Short circuit, etc.	Room 1	G	NG	Room 6	G	NG	
			Room 2	G	NG	Room 7	G	NG	
			Room 3	G	NG	Room 8	G	NG	
			Room 4	G	NG	Room 9	G	NG	
			Room 5	G	NG	Room 10	G	NG	

	Inspection item	Inspection method	Standard (guideline)	Measurement values				Decision
BS unit	Refrigerant system	Gas Leak detector or visual inspection	No leaks	BS 1	G NG	BS 6	G NG	
				BS 2	G NG	BS 7	G NG	
				BS 3	G NG	BS 8	G NG	
				BS 4	G NG	BS 9	G NG	
				BS 5	G NG	BS 10	G NG	
	Terminal connection section	Screw driver etc.	No looseness	BS 1	G NG	BS 6	G NG	
				BS 2	G NG	BS 7	G NG	
				BS 3	G NG	BS 8	G NG	
				BS 4	G NG	BS 9	G NG	
				BS 5	G NG	BS 10	G NG	
	Heat insulation	Visual inspection	No damage	BS 1	G NG	BS 6	G NG	
				BS 2	G NG	BS 7	G NG	
				BS 3	G NG	BS 8	G NG	
				BS 4	G NG	BS 9	G NG	
				BS 5	G NG	BS 10	G NG	
	Installation	Visual inspection	Hanging method, etc.	BS 1	G NG	BS 6	G NG	
				BS 2	G NG	BS 7	G NG	
				BS 3	G NG	BS 8	G NG	
				BS 4	G NG	BS 9	G NG	
				BS 5	G NG	BS 10	G NG	

## During operation

System name \_\_\_\_\_

	Inspection item	Inspection method	Standard (guideline)	Measurement values				Decision			
				R-S	V	S-T	V		R-T	V	
Outdoor unit	Main power supply voltage	Tester	Rated voltage $\pm 10\%$	R-S	V	S-T	V	R-T	V		
	Operation circuit voltage	Tester	Rated voltage $\pm 10\%$						V		
	Fan rotation direction	Visual inspection	Forward rotation			G	NG				
	Fan noise/vibration	Listening	No noise or vibration								
	Fan operation current	Clamp meter				RED A	WHITE A	BLACK A			
	Suction air temperature	Thermometer	Temperature differential 16.2~19.8deg. when cooling, 3.6~6.3deg. when heating							$^{\circ}\text{F}$	
	Discharge air temperature	Thermometer								$^{\circ}\text{F}$	
	Compressor discharge pressure	Pressure gauge								psi	
	Compressor suction pressure	Pressure gauge								psi	
	Compressor operating current	Clamp meter	Phase differential within 1A	INV	U( )A,	V( )A,	W( )A				
				STD1	R( )A,	S( )A,	T( )A				
				STD2	R( )A,	S( )A,	T( )A				
	Compressor operating frequency	Clamp meter		INV						Hz	
	Suction pipe temperature	Thermometer	37.4~59 $^{\circ}\text{F}$	INV		$^{\circ}\text{F}$	STD			$^{\circ}\text{F}$	
Discharge pipe temperature	Thermometer	185~221 $^{\circ}\text{F}$	INV		$^{\circ}\text{F}$	STD			$^{\circ}\text{F}$		
Clank case heater	Touch	Warm	INV		G·NG	STD			G·NG		
Indoor unit	Powerly supply voltage	Tester	Rated voltage $\pm 10\%$	Room 1	V	Room 6	V				
				Room 2	V	Room 7	V				
				Room 3	V	Room 8	V				
				Room 4	V	Room 9	V				
				Room 5	V	Room 10	V				
	Suction air temperature	Thermometer	Thermometer differential	Room 1	$^{\circ}\text{F}$	Room 6	$^{\circ}\text{F}$				
				Room 2	$^{\circ}\text{F}$	Room 7	$^{\circ}\text{F}$				
				Room 3	$^{\circ}\text{F}$	Room 8	$^{\circ}\text{F}$				
				Room 4	$^{\circ}\text{F}$	Room 9	$^{\circ}\text{F}$				
				Room 5	$^{\circ}\text{F}$	Room 10	$^{\circ}\text{F}$				
	Discharge air temperature	Thermometer	48.2~55.4 $^{\circ}\text{F}$ when cooling, 59~68 $^{\circ}\text{F}$ when heating	Room 1	$^{\circ}\text{F}$	Room 6	$^{\circ}\text{F}$				
				Room 2	$^{\circ}\text{F}$	Room 7	$^{\circ}\text{F}$				
				Room 3	$^{\circ}\text{F}$	Room 8	$^{\circ}\text{F}$				
				Room 4	$^{\circ}\text{F}$	Room 9	$^{\circ}\text{F}$				
				Room 5	$^{\circ}\text{F}$	Room 10	$^{\circ}\text{F}$				
	Fan rotation direction	Visual inspection	Forward rotation	Room 1	G NG	Room 6	G NG				
				Room 2	G NG	Room 7	G NG				
				Room 3	G NG	Room 8	G NG				
				Room 4	G NG	Room 9	G NG				
				Room 5	G NG	Room 10	G NG				
Fan noise/ vibration	Listening	No noise or vibration	Room 1	G NG	Room 6	G NG					
			Room 2	G NG	Room 7	G NG					
			Room 3	G NG	Room 8	G NG					
			Room 4	G NG	Room 9	G NG					
			Room 5	G NG	Room 10	G NG					
Fan operating current	Clamp meter	Room 1	A	Room 6	A						
		Room 2	A	Room 7	A						
		Room 3	A	Room 8	A						
		Room 4	A	Room 9	A						
		Room 5	A	Room 10	A						

## 7.8 Piping System Diagrams

### 7.8.1 Outdoor Unit

REYQ96MTJU

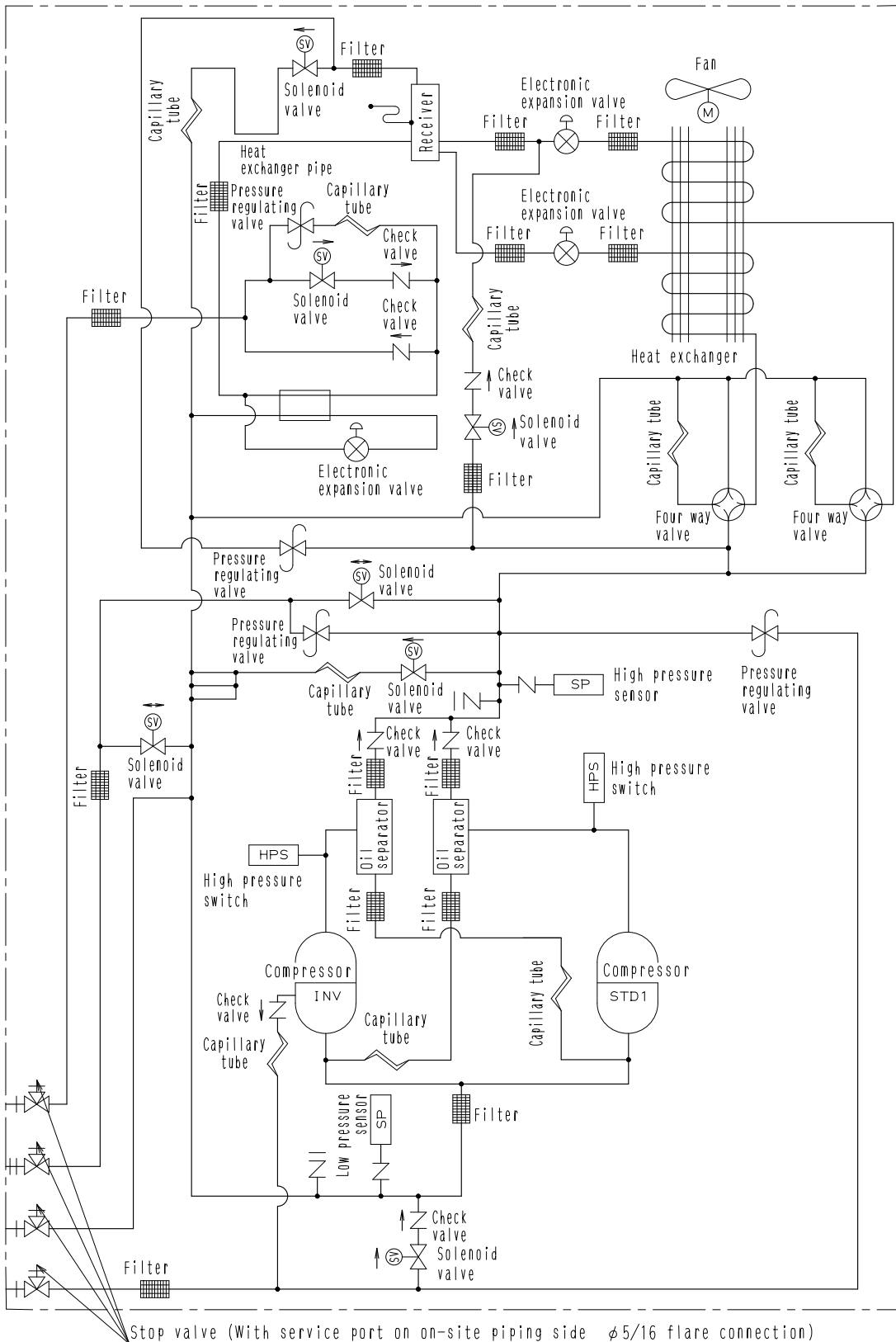

4D045329

## 7.8.2 Indoor Unit

FXFQ, FXSQ, FXMQ, FXAQ, FXLQ, FXNQ

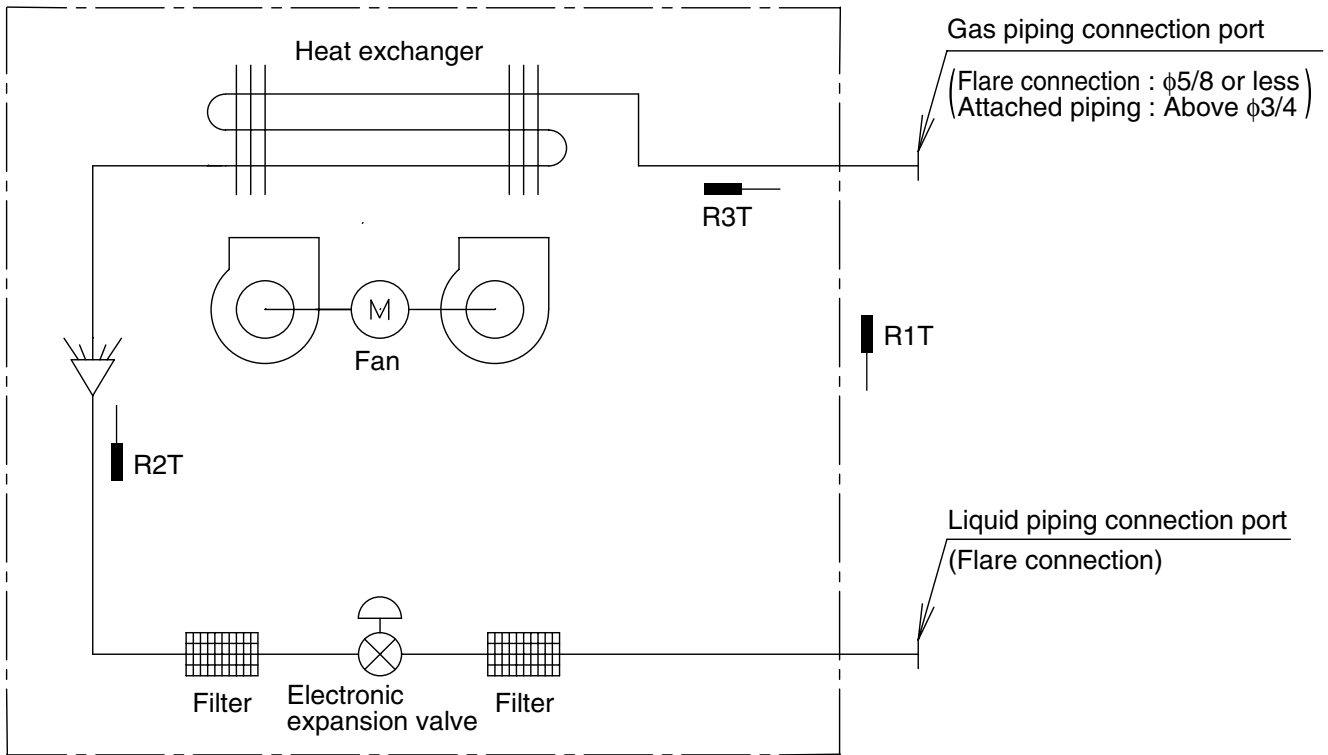

DU220-602D

R1T : Thermistor for suction air temperature

R2T : Thermistor for liquid line temperature

R3T : Thermistor for gas line temperature

(mm)

Capacity	GAS	Liquid
12/18M	$\phi 1/2$	$\phi 1/4$
24/30/36//48M	$\phi 5/8$	$\phi 3/8$

### 7.8.3 BS Unit

BSVQ36MVJ  
BSVQ60MVJ

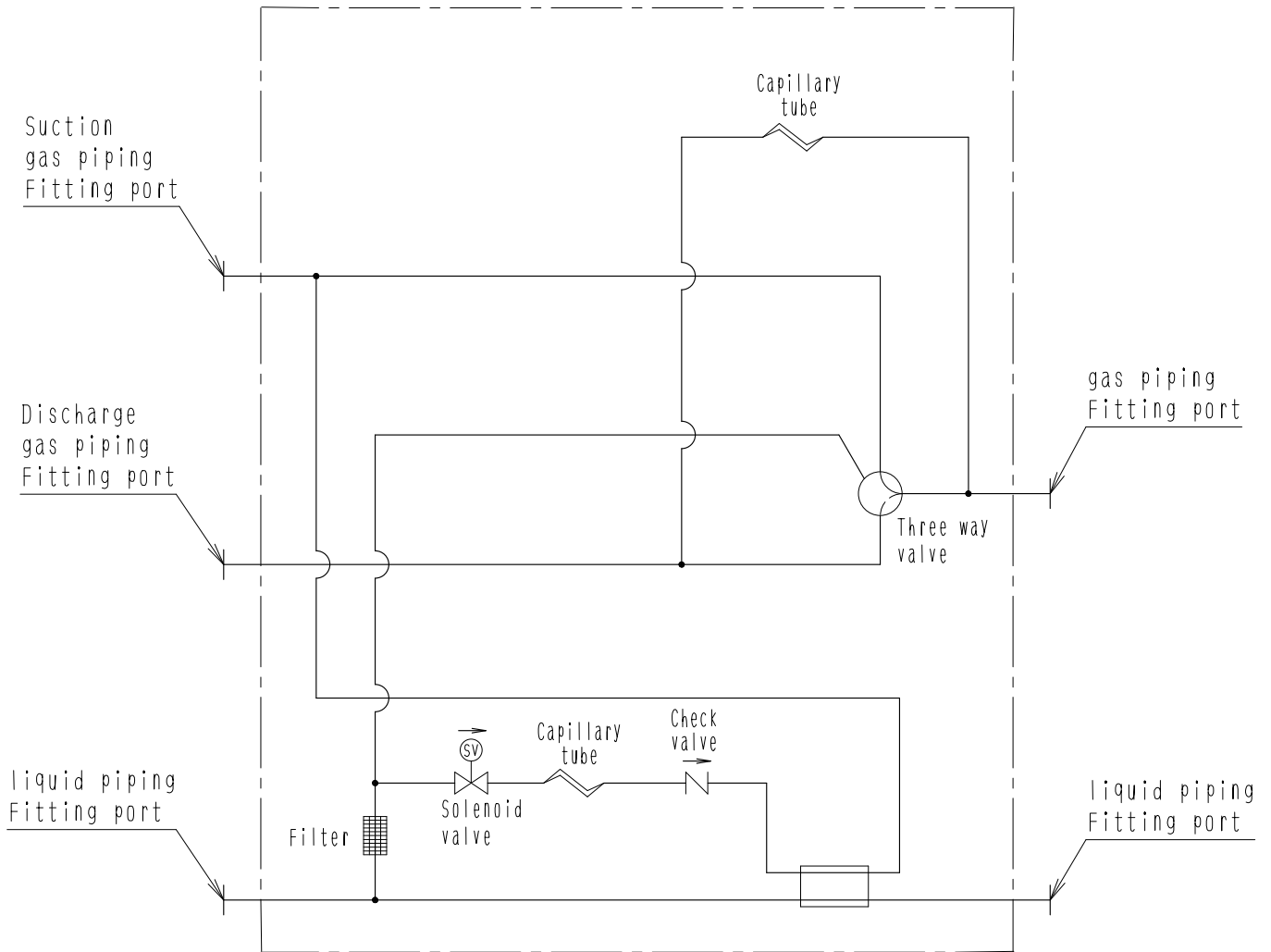

4D045338

# 7.9 Wiring Diagrams

## 7.9.1 Outdoor Unit

### REYQ96MTJU

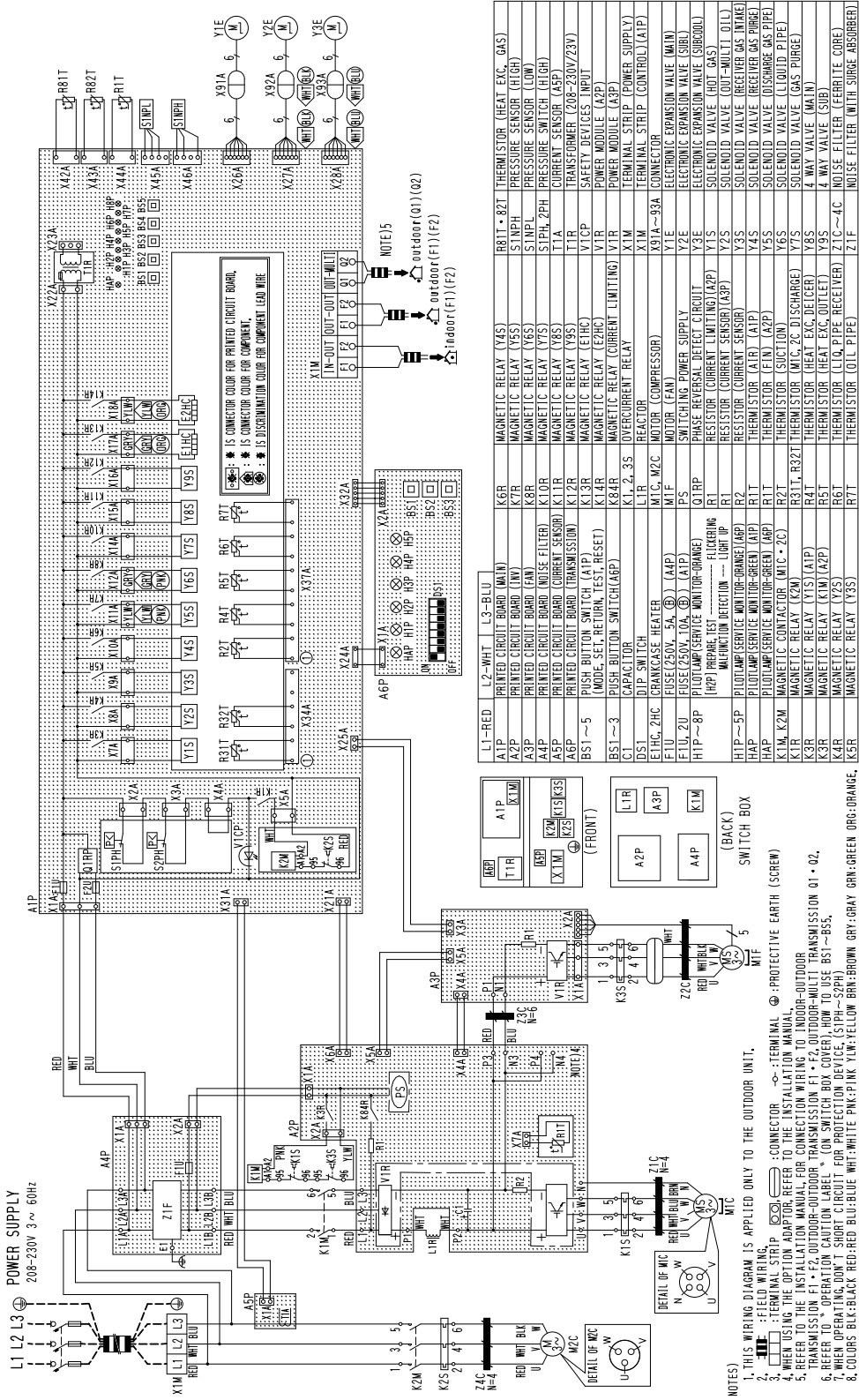

3D044892A

## 7.9.2 Field Wiring

### REYQ96MTJU

- Notes 1) All wiring, components and materials to be procured on the site must comply with the applicable local and national codes, to include all details for a specific installation.
- 2) Use copper conductors only.
- 3) As for details, see wiring diagram.
- 4) Install circuit breaker for safety.
- 5) All field wiring and components must be provided by licensed electrician.
- 6) Unit shall be grounded in compliance with the applicable local and national codes.
- 7) Wiring shown is general points-of-connection guides only and is not intended for or to include all details for a specific installation.
- 8) Be sure to install the switch and the fuse to the power line of each equipment.
- 9) Install the main switch that can interrupt all the power sources in an integrated manner because this system consists of the equipment utilizing the multiple power sources.

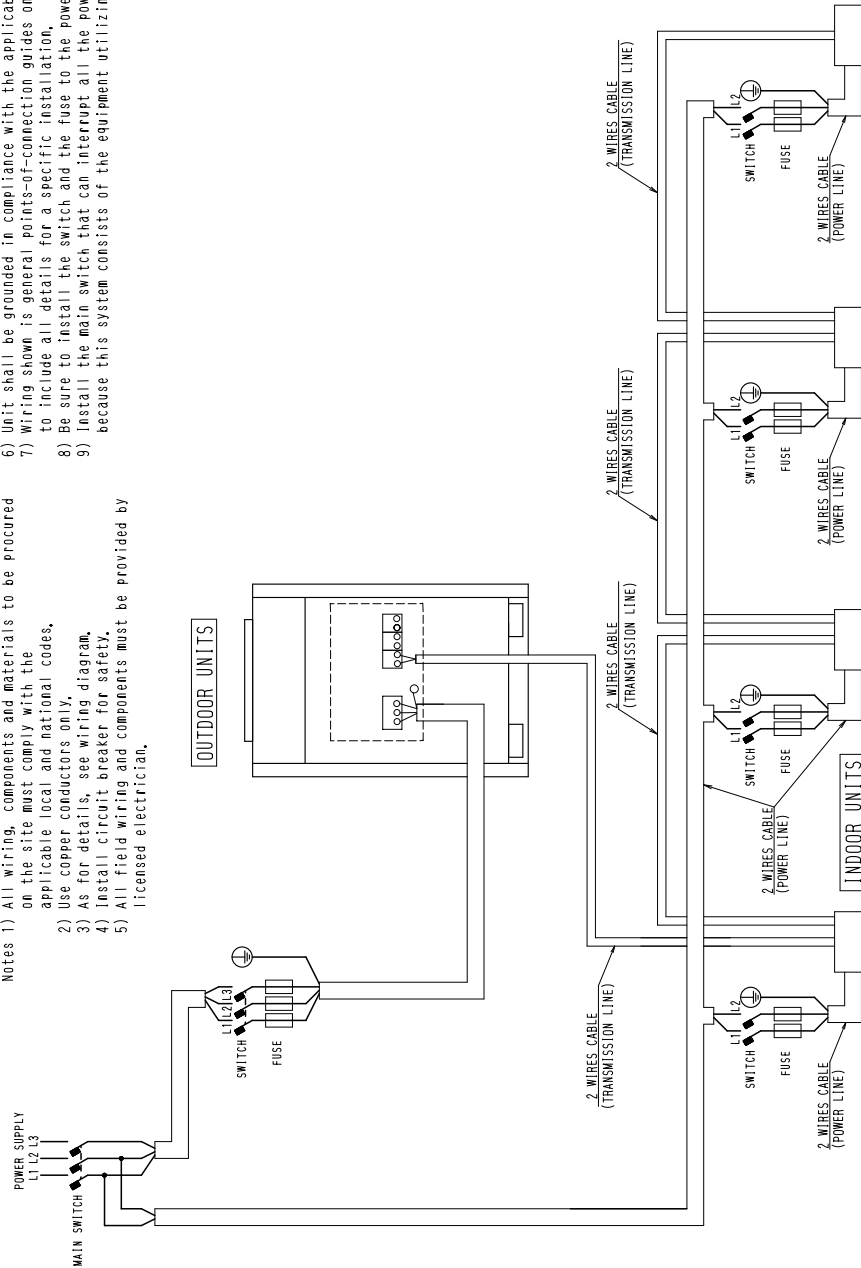

3D042647A



## 7.10 Bad Examples and Good Examples in Installation

### 7.10.1 Example 1: Signal interference due to use of multiple core cable (all model)

#### Situation

Although for the purposes of group control there are only 2 units per group there are transmission malfunctions between the indoor units and the remote controller and the remote controller's address display is showing non-existent addresses such as 13 or 15.

#### Source of Problem and Remedial Action

**Multiple core cable has been used** for at least part of the interconnecting wiring between the remote controller and the indoor units.

This has resulted in signal interference leading to a transmission malfunction.

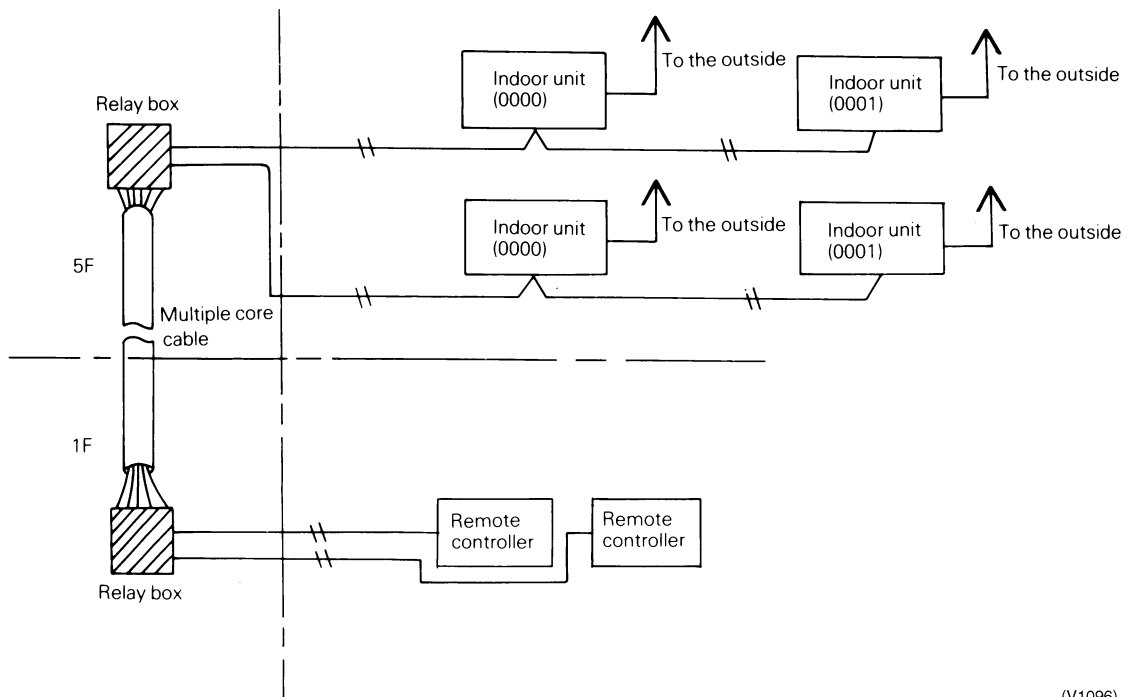

(V1096)

The multiple core cable was replaced by twin core cable and the fault disappeared.

#### Main Points

- Although twin core cable had been run from each unit, multiple core cable was used on the way.
- In schools, etc., because remote controllers are often installed in a single first floor control room, it is easier to use a multi-core cable.
- Signal interference can result in non-existent addresses appearing on the display.

## 7.10.2 Example 2: Mismatch between cables connecting indoor and outdoor units and corresponding piping. (all model)

### Situation

The remote controller is not showing any malfunction and the system is operating but there is no flow of warm air from the indoor unit (in heating mode).

### Source of Problem and Remedial Action

**The connecting cables and the corresponding piping were not correctly matched.**  
Recabbling was carried out and the fault disappeared.

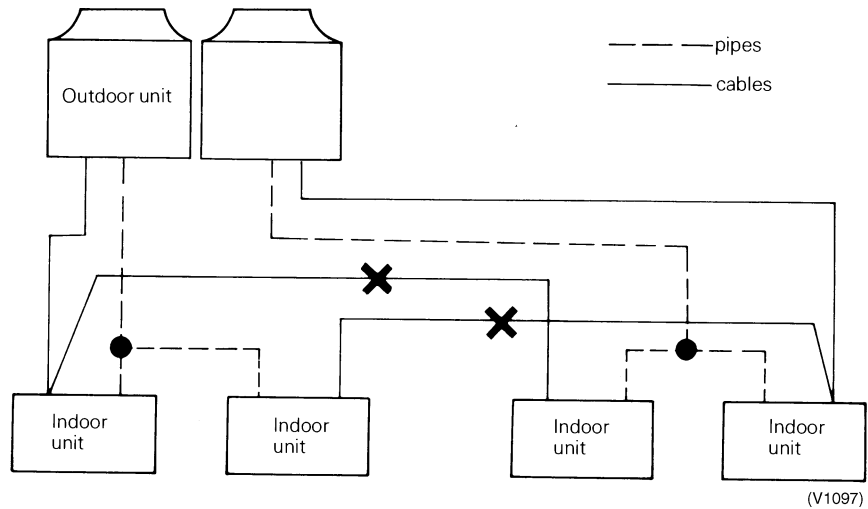

### Main Points

- Special care must be taken when the pipework and cabling are carried out by different people.
- Run each indoor unit in turn to check that the system is correctly matched.

### 7.10.3 Example 3: Drain pipe trap shape defective

**Situation** Indoor unit was fitted with a drain trap but a leak occurred during subsequent operation.

**Source of Problem and Remedial Action** The trap was not properly shaped thus preventing it from functioning effectively as a trap and resulting in drain leakage. The trap was reshaped and the fault disappeared.

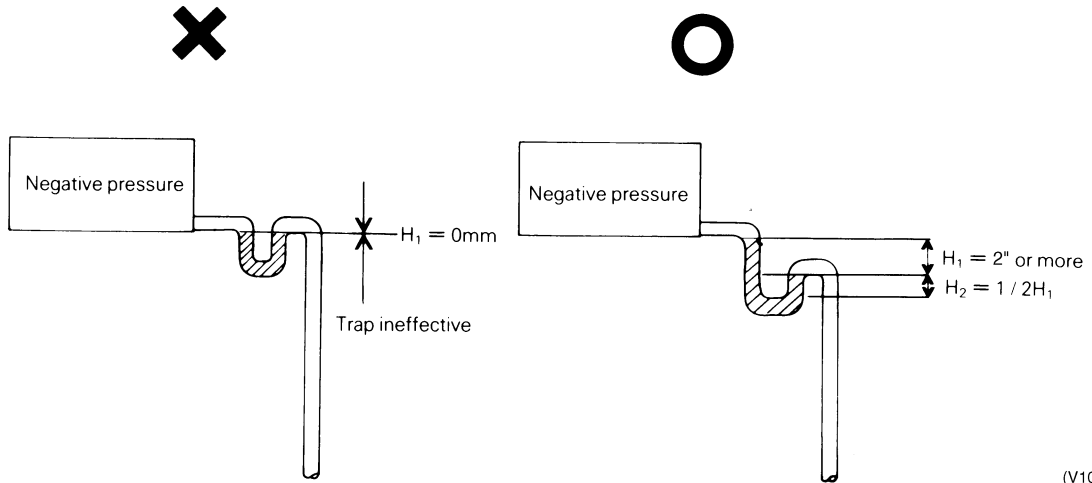

(V1098)

#### Main Points

- Duct types (18~48) require a drain trap.  
Reason: There is resistance on the air inlet side caused by the heat exchanger and air filter and this in turn creates negative pressure in relation to the atmospheric pressure on the discharge side. If there is no drain trap then air will be drawn in from the drain pipe and the waste water splashed around giving rise to the risk of water overflowing from the drain pan. To avoid this problem it is therefore necessary to design a trap which takes account of the maximum negative pressure which is likely to be created on the suction side.

### 7.10.4 Example 4: Pressure down despite absence of leaks during air tight test (all model)

#### Situation

In order to carry out local air tight tests on the refrigerant piping the system was pressurized via the liquid pipe service port and after 24 hours the pressure was found to have fallen. The local refrigerant piping alone does not lose any pressure. Maybe the gas leak is supposed to be located in the indoor unit itself.

#### Source of Problem and Remedial Action

The system was pressurized from the liquid pipe side and the gas pipes were therefore not pressurized. The system was then left under pressure for 24 hours but during that time gas leaked through into the gas pipes due to internal leaks within electronic expansion valves and the gas pressure inside the liquid pipes consequently dropped.

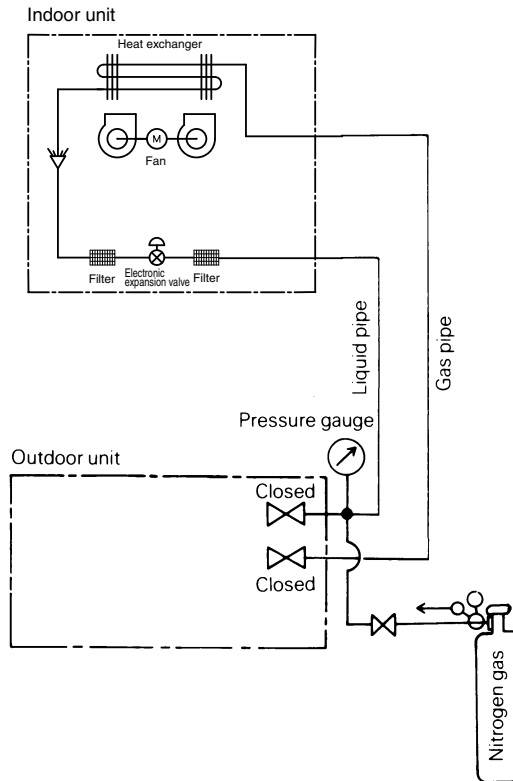

#### Main Points

When carrying out air tight tests on local pipework **it is essential that the system be pressurized via both the liquid pipes and the gas pipes.**

## 7.10.5 Example 5: Excessive noise due to incorrect angling of REFNET joints

**Situation** The noise of the refrigerant flow during defrosting is excessive.

**Source of Problem and Remedial Action** The angle of the fittings was incorrect and needed to be rectified as shown in the following figure.

### 1. REFNET joints

The REFNET joints should be installed such that branches meet the main pipe either horizontally or vertically at an angle of exactly 90 degrees.

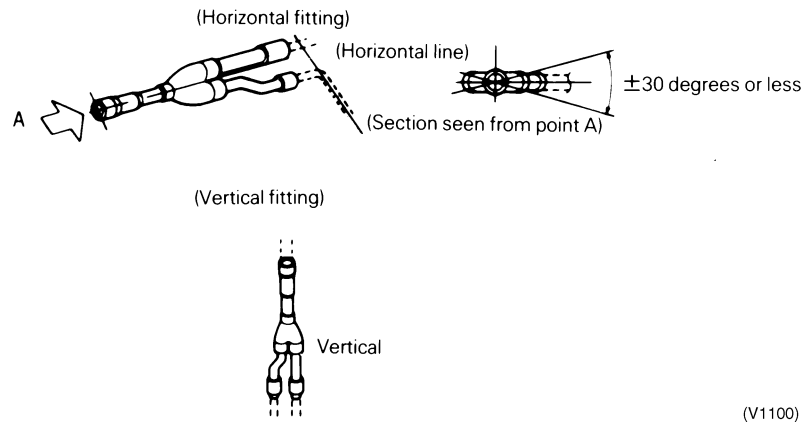

### 2. REFNET header

The REFNET header is a lateral flow pipe and should be fitted so as to allow horizontal branch fittings. (Vertical or sloping fitting is not permissible.)

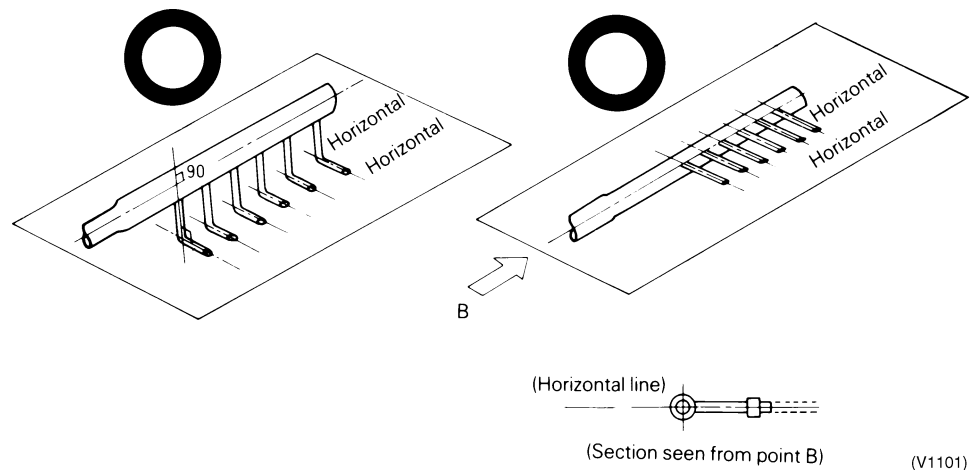

## Main Points

- Reasons for using refrigerant branch kit  
Fittings of REFNET joints or headers which are not carried out in strict accordance with the principles outlined here may result in complaints relating, for example, to “poor performance” of the system or “noisy refrigerant flow”. (To prevent unbalance flow or oil shortage)

## 7.10.6 Example 6: Cracks develop in field pipes due to thermal expansion and contraction

**Situation** Refrigerant piping has developed cracks in soldered points and is leaking gas.

**Cause** Both ends of the pipe have been tightly fixed in place.  
 ↓  
 Starting and stopping the compressor has caused temperature to vary, thus the pipes have expanded and contracted which places stress on soldered parts.  
 ↓  
 Cracks have formed because of repeated expansion and contraction.

**Remedial Action** Fit the pipe with a loop as shown in the below drawing.

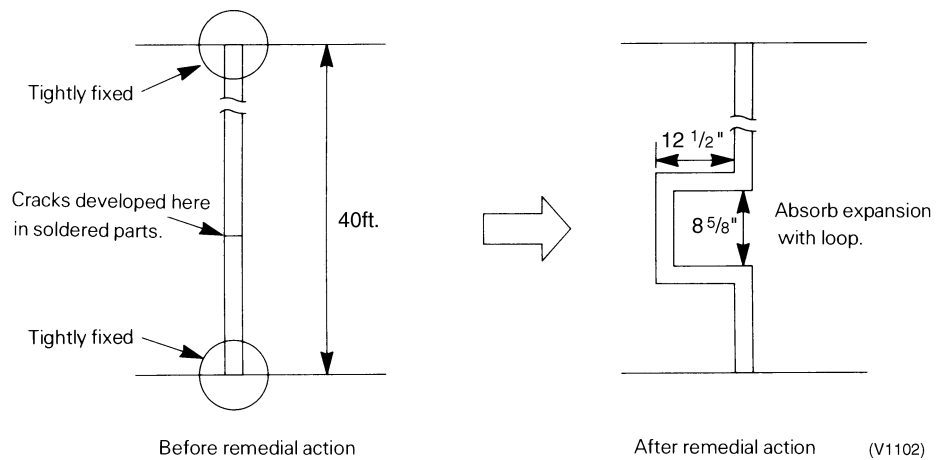

**Main Points** ■ Take thermal expansion and contraction along the spline into consideration when installing pipe supports.

**For Your Reference** Expansion (m) = Full length × Coefficient of thermal expansion × Rise in temperature  
 Coefficient of thermal expansion for copper:  $16.5 \times 10^{-6}$

Example For a pipe length of 10 m and a rise in temperature of 50°C, expansion reaches 8.2mm.

### 7.10.7 Example 7: Transmission wiring between the cool/heat selector and the outdoor unit is too close to a high voltage wire.

#### Situation

Heating is indicated despite having selected cooling with the cool/heat selector.

#### Cause and Remedial Action

The transmission wiring between the cool/heat selector and the outdoor unit is too close to a high voltage wire. An induced voltage is, therefore, being impressed on the transmission wiring which is causing a heating/cooling malfunction in the outdoor unit PC board.

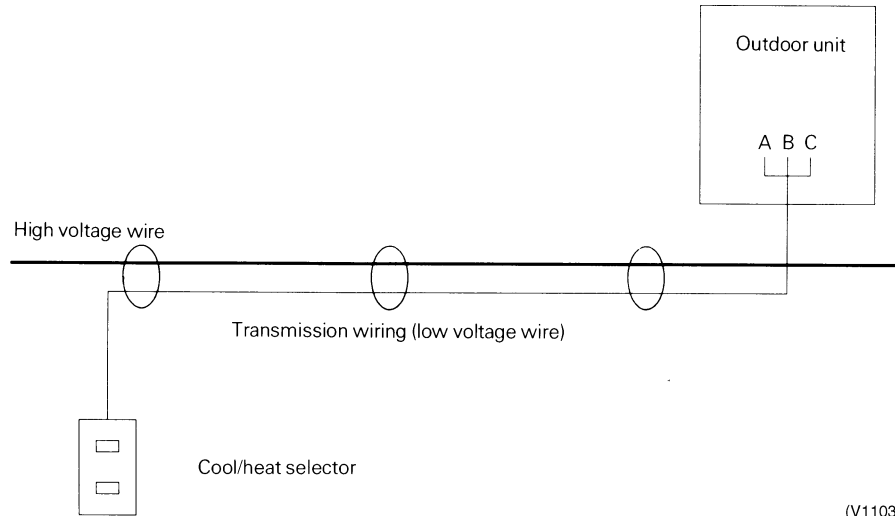

(V1103)

Bypassing the transmission wiring will allow the unit to function normally.

#### Main Points

- Keep low and high voltage wiring away from each another.

### 7.10.8 Example 8: The centralized control group number cannot be set (Inverter K Series).

#### Situation

An attempt was made to set the centralized control group number with the indoor unit remote controller, but "00" cannot be selected in the field setting mode.

#### Cause

1. The central remote controller or unified ON/OFF controller is OFF.
2. The central remote controller or unified ON/OFF controller, or indoor unit is not wired to the centralized control line (F1 & F2).

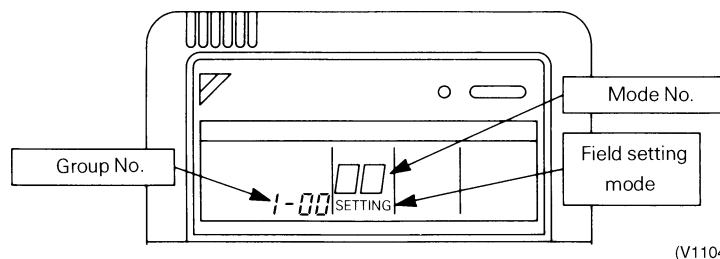

(V1104)

#### Remedial Action

Supply power to either the central remote controller or unified ON/OFF controller.  
Wire the central remote controller or unified ON/OFF controller, or indoor unit to the centralized control line.

**Main Points**

- When communications with the central remote controller are down, “00” cannot be selected in the field setting mode.
- Activate power to the central remote controller, unified ON/OFF controller and indoor unit before setting the centralized control group number.

**7.10.9 Example 9: “88” cannot be cleared from the central remote controller.****Situation**

The display on the central remote controller does not change from its initial state after turning power ON.

Initial display of the central remote controller

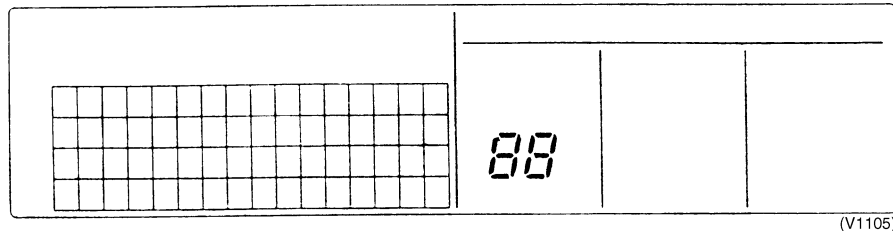
**Cause**

1. None of the indoor units connected to the central remote controller have been given a group No.
2. The connector for setting the master controller inside the central remote controller is disconnected.

**Remedial Action**

- Set a centralized control group No. for each indoor unit with the respective remote controllers.
- Connect the connector for setting the master controller in one of the central remote controller.

**Main Points**

- If the setting for master controller has been changed, reset the power to the unit at the ON/OFF switch or the forced reset switch of the controller.
- Activate power to the central remote controller, unified ON/OFF controller and indoor unit before setting the centralized control group No.
- For details on how to set the centralized control group number, refer to the installation manual.



# Part 2

# Installation Manual

# REYQ96MTJU

1. Introduction .....	136
1.1 Combination .....	136
1.2 Standard Operation Limit .....	136
1.3 Standard Supplied Accessories .....	137
1.4 Option Accessory .....	138
1.5 Technical Specifications (1) .....	138
1.6 Electrical Specifications (1) .....	139
2. Main Components .....	140
3. Selection of Location .....	141
4. Inspecting and Handling the Unit .....	143
5. Unpacking and Placing the Unit .....	144
6. Refrigerant Piping .....	146
6.1 Selection of Piping Material .....	146
6.2 Connecting the Refrigerant Piping .....	146
6.3 Example of Connection .....	151
6.4 Leak Test and Vacuum Drying .....	153
6.5 Pipe Insulation .....	156
6.6 Additional Refrigerant Charge .....	156
7. Field Wiring .....	159
7.1 Optional Parts .....	159
7.2 Power Circuit and Cable Requirements .....	159
7.3 General .....	160
7.4 Examples .....	161
8. Before Operation .....	166
8.1 Checks Before Initial Start-up .....	166
8.2 Test Run .....	167
9. Caution for Refrigerant Leaks .....	169

**[Applicable models]**  
**REYQ96MTJU**

Please read these "SAFETY CONSIDERATIONS" carefully before installing air conditioning equipment and be sure to install it correctly.

After completing the installation, make sure that the unit operates properly during the start-up operation.

Please instruct the customer on how to operate the unit and keep it maintained.

Also, inform customers that they should store this installation manual along with the operation manual for future reference.

This air conditioner comes under the term "appliances not accessible to the general public".

Meaning of warning, caution and note symbols.



**WARNING** ..... Indication a potentially hazardous situation which, if not avoided, could result in death or serious injury.



**CAUTION** ..... Indication a potentially hazardous situation which, if not avoided, may result in minor or moderate injury. It may also be used to alert against unsafe practices.



**Note** ..... Indication situation that may result in equipment or property-damage-only accidents.



**WARNING**

- **Ask your dealer or qualified personnel to carry out installation work. Do not try to install the machine by yourself.**  
Improper installation may result in water leakage, electric shocks or fire.
- **Perform installation work in accordance with this installation manual.**  
Improper installation may result in water leakage, electric shocks or fire.
- **When installing the unit in a small room, take measures against to keep refrigerant concentration from exceeding allowable safety limits in the event of refrigerant leakage.**  
Contact the place of purchase for more information. Excessive refrigerant in a closed ambient can lead to oxygen deficiency.
- **Be sure to use only the specified accessories and parts for installation work.**  
Failure to use the specified parts may result in water leakage, electric shocks, fire or the unit falling.
- **Install the air conditioner on a foundation strong enough to withstand the weight of the unit.**  
A foundation of insufficient strength may result in the equipment falling and causing injuries.
- **Carry out the specified installation work after taking into account strong winds, typhoons or earthquakes.**  
Improper installation work may result in the equipment falling and causing accidents.
- **Make sure that a separate power supply circuit is provided for this unit and that all electrical work is carried out by qualified personnel according to local laws and regulations and this installation manual.**  
An insufficient power supply capacity or improper electrical construction may lead to electric shocks or fire.
- **Make sure that all wiring is secured, the specified wires are used, and no external forces act on the terminal connections or wires.**  
Improper connections or installation may result in fire.

- **When wiring the power supply and connecting the remote controller wiring and transmission wiring, position the wires so that the electric parts box lid can be securely fastened.**  
Improper positioning of the electric parts box lid may result in electric shocks, fire or the terminals overheating.
- **If the refrigerant gas leaks during installation, ventilate the area immediately.**  
Toxic gas may be produced if the refrigerant gas comes into contact with fire.
- **After completing the installation work, check that the refrigerant gas does not leak.**  
Toxic gas may be produced if the refrigerant gas leaks into the room and comes into contact with a source of fire, such as a fan heater, stove or cooker.
- **Before touching electrical parts, turn off the unit.**
- **Ground the air conditioner. Do not connect the ground wire to gas or water pipes, lightning rod or a telephone ground wire.**  
Incomplete grounding may result in electric shocks.
- **Securely install the outdoor unit terminal cover (panel).**  
If the terminal cover (panel) is not installed properly, dust or water may enter the outdoor unit and fire or electric shock may result.
- **When installing or relocating the system, be sure to keep the refrigerant circuit free from substances other than the specified refrigerant (R410A), such as air.**  
Any presence of air or other foreign substance in the refrigerant circuit causes an abnormal pressure rise or rupture, resulting in injury.
- **Do not reconstruct or change the settings of the protection devices.**  
If the pressure switch, thermal switch, or other protection device is shorted and operated forcibly, or parts other than those specified by Daikin are used, fire or explosion may result.
- **Do not touch the switch with wet fingers.**  
Touching a switch with wet fingers can cause electric shock.
- **Install an leak circuit breaker, as required.**  
If an leak circuit breaker is not installed, electric shock may result.

**CAUTION**

- **While following the instructions in this installation manual, install drain piping in order to ensure proper drainage and insulate piping in order to prevent condensation.**  
Improper drain piping may result in water leakage and property damage.
- **Do not touch the heat exchanger fins.**  
Improper handling may result in injury.
- **Be very careful about product transportation.**
- **Safely dispose of the packing materials.**  
Packing materials, such as nails and other metal or wooden parts, may cause stabs or other injuries.  
Tear apart and throw away plastic packaging bags so that children will not play with them. If children play with a plastic bag which was not torn apart, they face the risk of suffocation.

- **Do not touch the refrigerant pipes during and immediately after operation.**  
During and immediately after operation, the refrigerant pipes are may be hot and may be cold, depending on the condition of the refrigerant flowing through the refrigerant piping, compressor, and other refrigerant cycle parts. Your hands may suffer burns or frostbite if you touch the refrigerant pipes.
- **Do not turn off the power immediately after stopping operation.**  
Always wait at least five minutes before turning off the power.  
Otherwise, water leakage and trouble may occur.
- **Do not use a charging cylinder.**  
Using a charging cylinder may cause the refrigerant to deteriorate.



**Note:**

- **Install the indoor and outdoor units, power supply wiring and connecting wires at least 3.5ft. away from televisions or radios in order to prevent image interference or noise.**  
(Depending on the radio waves, a distance of 3.5ft. may not be sufficient enough to eliminate the noise.)
- **This unit is a class A product.**  
In a domestic environment this product may cause radio interference in which case the user may be required to take adequate measures.
- **Dismantling of the unit, treatment of the refrigerant, oil and eventual other parts, should be done in accordance with the relevant local and national regulations.**
- **Do not use the following tools that are used with conventional refrigerants. (Gauge manifold, charge hose, gas leak detector, reverse flow check valve, refrigerant charge base, vacuum gauge, refrigerant recovery equipment.)**  
If the conventional refrigerant and refrigerator oil are mixed in the R410A, the refrigerant may deteriorated.
- **Never perform outdoor unit piping connection work when it is raining.**



**CAUTION**

The refrigerant R410A requires strict cautions for keeping the system clean, dry and tight.

A.Clean and dry

Foreign materials (including mineral oils such as SUNISO oil or moisture) should be prevented from getting mixed into the system.

B.Tight

R410A does not contain any chlorine, does not destroy the ozone layer, and does not reduce the earth's protection against harmful ultraviolet radiation.

R410A can contribute slightly to the greenhouse effect if it is released. Therefore we should take special attention to check the tightness of the installation.

Read the chapter "Refrigerant piping" carefully and follow these procedures correctly.



**CAUTION**

Since R410A is a mixed refrigerant, the required additional refrigerant must be charged in its liquid state. (If the refrigerant is charged in a state of gas, its composition changes and the system will not work properly.)

The indoor unit is for R410A. See the catalog for indoor unit models which can be connected.

(Normal operation is not possible when connected to other units.)



**CAUTION**

Do not allow children to mount on the outdoor unit, or avoid placing any object on it. Falling or tumble may result in injury.

---

**Safety Precaution**

The PCI Data Station is a class A product. In a domestic environment this product may cause radio interference in which case the user may be required to take adequate measures.

# 1. Introduction

This installation manual concerns VRV inverters of the Daikin REYQ-M series. These units are designed for outdoor installation and used for cooling and heatpump applications. The REYQ-M units can be combined with Daikin VRV series indoor units for air conditioning purposes.

The present installation manual describes the procedures for unpacking, installing and connecting the REYQ-M units. Installation of the indoor units is not described in this manual. Always refer to the installation manual supplied with these units for their installation.

## 1.1 Combination

The indoor units can be installed in the following range.

- **Always use appropriate indoor units compatible with R410A.**  
**To lean which models of indoor units are compatible with R410A, refer to the product catalogs.**
- Total capacity/quantity of indoor units

< Outdoor unit > < Total capacity of indoor units > < Total quantity of indoor units >  
 REYQ96MTJU .....48 ~ 12010 units

## 1.2 Standard Operation Limit

The figures below assume following operating conditions for indoor and outdoor units:

Equivalent pipe length .....25ft.  
 Level difference .....0ft.

**Cooling**

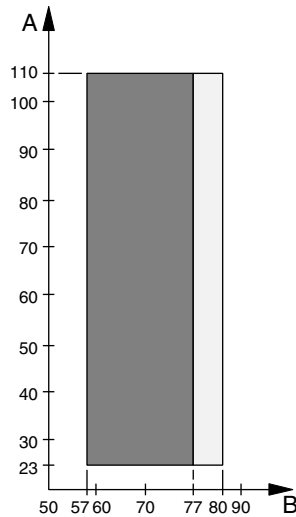



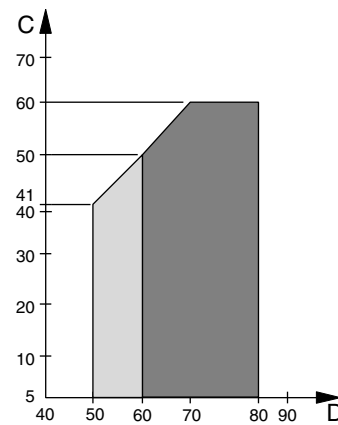



**Heating**





- A Outdoor temperature (°FDB)
- B Indoor temperature (°FWB)
- C Outdoor temperature (°FWB)
- D Indoor temperature (°FDB)
- Range for continuous operation
- Range for pull down operation
- Range for warming up operation

## 1.3 Standard Supplied Accessories

Name	Clamp (1)	Clamp (2)	Clamp (3)	Suction gas line piping attached to unit (1)
Quantity	9 pcs.	2 pcs.	1 pc.	1 pc.
Shape	 Small		 Large	

Name	Suction gas line piping attached to unit (2)	Suction gas line piping attached to unit (3)	Discharge gas line piping attached to unit (1)*
Quantity	1 pc.	1 pc.	1 pc.
Shape			

Name	Discharge gas line piping attached to unit (2)	Discharge gas line piping attached to unit (3)	Vinyl tube	Others
Quantity	1 pc.	1 pc.	1 pc.	<ul style="list-style-type: none"> <li>• Operation manual</li> <li>• Installation manual</li> <li>• Additional refrigerant charge label</li> </ul>
Shape				

\* Use the flare nut attached to the discharge gas shutoff valve for the "discharge gas line piping attached to unit" (1).

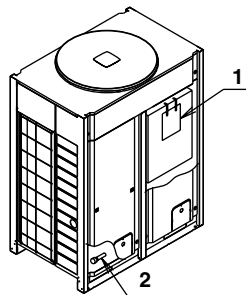

1. Operation manual Installation manual Clamp
2. Attached pipe

## 1.4 Option Accessory

To install the outdoor unit, the following optional parts are also required.

- **Refrigerant branching kit (For R410A only: Always use an appropriate kit dedicated for your system.)**

### for 3 pipes

REFNET header	—	KHRP25M33H
REFNET joint	KHRP25M22T	KHRP25M33T

### for 2 pipes

REFNET header	KHRP26M22H	KHRP26M33H
REFNET joint	KHRP26M22T	KHRP26M33T

\* To select an optimum refrigerant branching kit, refer to “6. Refrigerant Piping”.

## 1.5 Technical Specifications (1)

General		REYQ96MTJU	
Norminal cooling capacity (2)		MBh	96.0
Norminal heating capacity (3)		MBh	108.0
Norminal input cooling / heating (4)		kW	8.67 / 9.19
Dimensions H x W x D		inch	64 x 48 7/8 x 30 1/8
Mass		lb.	650
Connections	Refrigerant suction gas pipe	inch	7/8
	Refrigerant discharge gas pipe	inch	3/4
	Refrigerant liquid pipe	inch	3/8
Compressor		REYQ96MTJU	
Oil type		—	Synthetic (ether) oil
Oil charge volume		l	1.9 + 1.6
Crankcase heater		W	33 + 33
Refrigerant type		—	R410A
Refrigerant charge		lb.	27.3
Condenser		REYQ96MTJU	
Nominal air flow		CFM	7400
Fan motor output		W	750

(1) Refer to the engineering data book for the complete list of specifications.

(2) The nominal cooling capacity is based on: - indoor temperature: 80°FDB / 67°FWB  
 - outdoor temperature: 95°FDB  
 - pipe length: 25ft.  
 - level difference: 0ft.

(3) The nominal heating capacity is based on: - indoor temperature: 70°FDB  
 - outdoor temperature: 47°FDB / 43°FWB  
 - pipe length: 25ft.  
 - level difference: 0ft.

(4) The nominal input includes total input of the unit: compressor, fan motor and control circuit.



## 1.6 Electrical Specifications (1)

Model			REYQ96MTJU	
Power supply	Phase	—	3 ~	
	Frequency	Hz	60	
	Voltage	V	208 ~ 230	
	Voltage tolerance	%	±10	
	Recommended fuses	A	70	
Compressor	Phase	—	3 ~	
	Frequency	Hz	60	
	Voltage	V	208 ~ 230	
	Nominal running current	A	10.1 + 13.1	
Control and fan motor	Type	Voltage	V	208 ~ 230
		Nominal running current	A	4.5

## 2. Main Components

For main components and function of the main components, refer to the Engineering Data Book.

### 3. Selection of Location

This unit, both indoor and outdoor, is suitable for installation in a commercial and light industrial environment. **If installed as a household appliance it could cause electromagnetic interference.**

The VRV OUTDOOR units should be installed in a location that meets the following requirements:

1. The foundation is strong enough to support the weight of the unit and the floor is flat to prevent vibration and noise generation.
2. The space around the unit is adequate for servicing and the minimum space for air inlet and air outlet is available.

(refer to figure 1 and choose one of both possibilities)

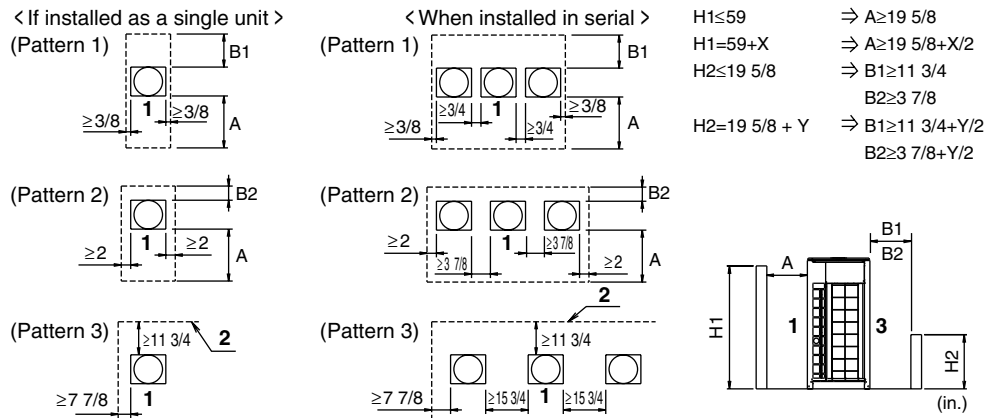

1. Front side
2. No limit to wall height
3. Suction side

3. There is no danger of fire due to leakage of inflammable gas.
4. Ensure that water cannot cause any damage to the location in case it drips out the unit (e.g. in case of a blocked drain pipe).
5. The piping length between the outdoor unit and the indoor unit may not exceed the allowable piping length. (see "Example of connection")
6. Select the location of the unit in such a way that neither the discharged air nor the sound generated by the unit disturb anyone.
7. Make sure that the air inlet and outlet of the unit are not positioned towards the main wind direction. Frontal wind will disturb the operation of the unit. If necessary, use a windscreen to block the wind.



#### CAUTION

1. An inverter air conditioner may cause electronic noise generated from AM broadcasting. Examine where to install the main air conditioner and electric wires, keeping proper distances away from stereo equipment, personal computers, etc.

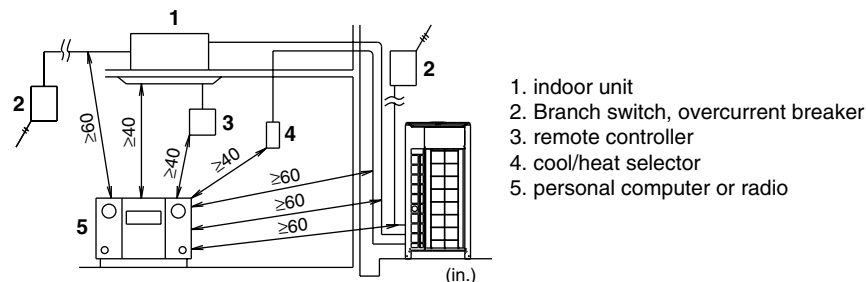

If the electric wave of AM broadcasting is particularly weak, keep distances of 10ft. or more and use conduit tubes for power and transmission lines.

2. In heavy snowfall areas, select an installation site where snow will not affect operation of the unit.



**WARNING**

1. The refrigerant R410A itself is nontoxic, nonflammable and safe. If the refrigerant should leak however, its concentration may exceed the allowable limit depending on room size. Due to this it could be necessary to take measures against leakage.  
Refer to the chapter "Caution for refrigerant leaks".
2. Do not install in the following locations.
  - Locations such as kitchens which contain a lot of mineral oil or steam in the atmosphere or where oil may splatter on the unit.  
Resin parts may deteriorate, causing the unit to fall or leak.
  - Locations where sulfurous acids and other corrosive gases may be present in the atmosphere.  
Copper piping and soldered joints may corrode, causing refrigerant to leak.
  - Locations where equipment that produces electromagnetic waves is found.  
The electromagnetic waves may cause the control system to malfunction, preventing normal operation.
  - Locations where flammable gases may leak, where thinner, gasoline, and other volatile substances are handled, or where carbon dust and other incendiary substances are found in the atmosphere.  
Leaked gas may accumulate around the unit, causing an explosion.

## 4. Inspecting and Handling the Unit

At delivery, the package should be checked and any damage should be reported immediately to the carrier claims agent.

When handling the unit, take into account the following:

1.  Fragile, handle the unit with care.  
 Keep the unit upright in order to avoid compressor damage.
2. Choose the path along which the unit is to be brought in ahead of time.
3. If a forklift is to be used, pass the forklift arms through the large openings on the bottom of the unit.
4. Lift the unit preferably with a crane and 2 belts of at least 27ft. long.
5. When lifting the unit with a crane, always use protectors to prevent belt damage and pay attention to the position of the unit's centre of gravity.
6. After installation, remove the transport clasps attached to the large openings.
7. Bring the unit as close to its final installation position in its original package to prevent damage during transport.

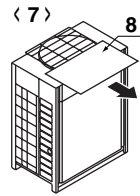
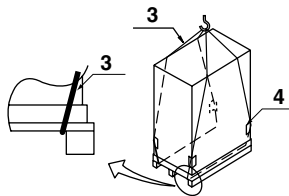
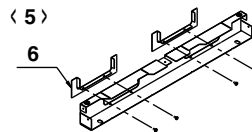
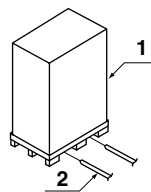

1. Packaging material
2. Forklift
3. Belt sling
4. Wear plate
5. Removal of shipping brackets
6. Shipping bracket (Remove the screws.)
7. Removal of corrugated paper
8. Corrugated paper

## 5. Unpacking and Placing the Unit

- Make sure the unit is installed level on a sufficiently strong base to prevent vibration and noise.
- Secure the unit to its base using foundation bolts. (Use four commercially available M12-type foundation bolts, nuts, and washers.)
- The foundation bolts should be inserted 13/16".

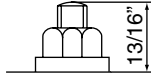

- Make sure the base under the unit extended more than 30 1/8" behind the unit.
- The height of the base should be at least 5 7/8" from the floor.
- The unit must be installed on a solid longitudinal foundation (steelbeam frame or concrete) as indicated in figure 4.

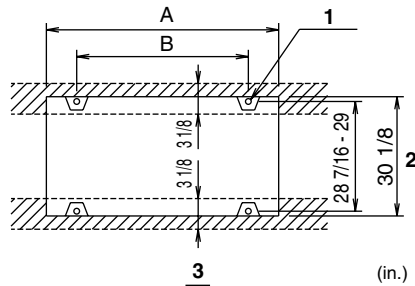

1. Foundation bolt point ( $\phi 9/16$ " dia. : 4 positions)
2. Depth of product
3. Shape of outdoor unit's support leg and foundation bolt positions

Model	A (in.)	B (in.)
Q96 type	48 13/16	43 3/8

### DO NOT USE STANDS TO SUPPORT THE CORNERS

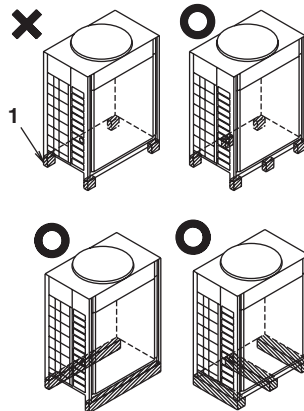

1. Do not use stands to support the corners.



### CAUTION

1. Prepare a water drainage channel around the foundation to condensate waste water from around the unit.
2. If the unit is to be installed on a roof, check the strength of the roof and its drainage facilities first.
3. If the unit is to be installed on a frame, install the waterproofing board within a distance of 5 7/8" under the unit in order to prevent infiltration of water coming from under the unit.

**CAUTION**

- When installing on a roof, make sure the roof floor is strong enough and be sure to water-proof all work.
- Make sure the area around the machine drains properly by setting up drainage grooves around the foundation.  
(Condensate water is sometimes discharged from the outdoor unit when it is running.)
- Block all gaps in the holes for passing out piping and wiring using sealing material (locally procured).  
(Small animals may enter the machine.)

Ex: passing piping out through the front

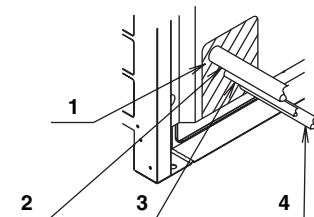

1. Plug the areas marked with "▨".  
(When the piping is routed from the front panel.)
2. Suction gas side piping
3. Liquid side piping
4. Discharge gas side piping

## 6. Refrigerant Piping



### CAUTION

After completing installation, be sure to open the valve.

(See **6-6 Additional refrigerant charge** for details) (Operating the unit with the valve shut will break the compressor.)

Use R410A to add refrigerant. (The R410A refrigerant cylinder has a pink stripe painted around it.)

All field piping must be installed by a licensed refrigeration technician and must comply with relevant local and national regulations.

### CAUTION TO BE TAKEN WHEN BRAZING REFRIGERANT PIPING

Do not use flux when brazing copper-to copper refrigerant piping.

(Particularly for the HFC refrigerant piping) Therefore, use the phosphor copper brazing filter metal (BCuP) which does not require flux.

(Flux has extremely harmful influence on refrigerant piping systems.)

For instance, if the chlorine based flux is used, it will cause pipe corrosion or, in particular, if the flux contains fluorine, it will damage the refrigerant oil.)



### Note:

#### ■ Installation tools:

Make sure to use installation tools (gauge manifold charge hose, etc.) that are exclusively used for R410A installations to withstand the pressure and to prevent foreign materials (e.g. mineral oils such as SUNISO and moisture) from mixing into the system.

(The screw specifications differ for R410A.)

Vacuum pump (use a 2-stage vacuum pump with a non-return valve):

1. Make sure the pump oil does not flow oppositely into the system while the pump is not working.
2. Use a vacuum pump which can evacuate to -14.6 psi.

## 6.1 Selection of Piping Material

1. Foreign materials inside pipes (including oils for fabrication) must be 9mg/10ft or less.
2. Use the following material specification for refrigerant piping:
  - construction material: Phosphoric acid deoxidized seamless copper for refrigerant.
  - size: Determine the proper size referring to chapter "Example of connection".
  - The wall thickness of the refrigerant piping should comply with relevant local and national regulations.
3. Make sure to use the particular branches of piping that have been selected referring to chapter "Example of connection".

## 6.2 Connecting the Refrigerant Piping

1. The local branch piping can be connected either forward or to the sides (taken out of the bottom) as shown in the figure.

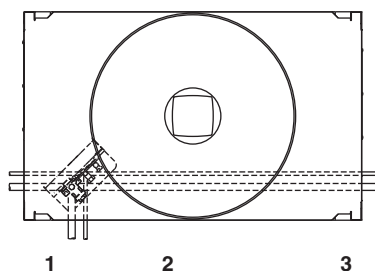

1. Left-side connection
2. Front connection
3. Right-side connection



**[One outdoor unit installed]**

## ■ Front connection:

Remove the shutoff valve cover to connect

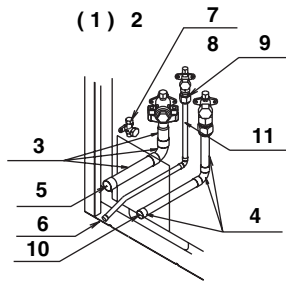

1. Front connection:
  2. Remove the shutoff valve cover to connect.
  3. Suction gas side accessory pipe (1) (2) (3)
  4. Discharge gas side accessory pipe (1)(2)(3)
  5. Suction gas line
  6. Liquid gas line
  7. Oil-equalizing piping shutoff valve
  8. No piping work is needed.
  9. Flare nut
  10. Discharge gas line
  11. Liquid side piping (field supply)
12. Side (bottom) connection:
13. Remove the knock holes on the bottom frame and route the piping under the bottom frame.
  14. Knockout hole
  15. Punch the knock holes.
  16. Discharge gas piping (field supply)
  17. Liquid gas piping (field supply)
  18. Suction gas piping (field supply).

## ■ Side (bottom) connection:

Remove the knock holes on the bottom frame and route the piping under the bottom frame.

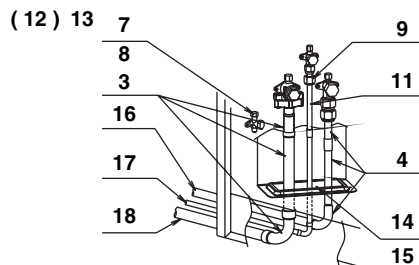
**CAUTION**

Be sure to use the attached pipe when carrying out piping work in the field.

Be sure that the local piping does not touch other pipes, the bottom panel or side panel. Especially for the bottom and side connection, be sure to protect the local piping with the provided insulation, to prevent it from coming into contact with the casing.

**Precautions when knocking out knock holes**

- Be sure to avoid damaging the casing
- After knocking out the holes, we recommend you paint the edges and areas around the edges using the repair paint to prevent rusting.
- When passing electrical wiring through the knock holes, wrap the wiring with protective tape to prevent damage.
- Open knock holes around the 4 concave knock holes in the base frame, using a  $\phi 1/4$ "-bit drill.

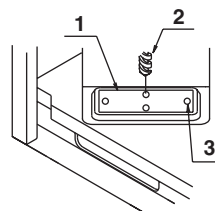

1. Knock hole
2. Drill
3. Concave section

2. Make sure to perform the piping installation within the range of the maximum allowable pipe length, allowable level difference and allowable length after branching as indicated in chapter "Example of connection"
3. For installation of the refrigerant branching kit, refer to the installation manual delivered with the kit.

Mount the REFNET joint so that it branches either horizontally or vertically.

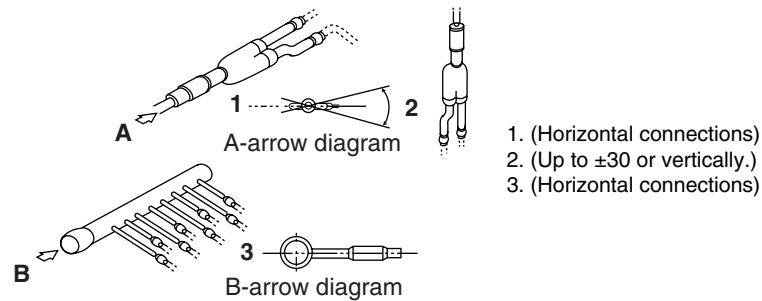

Mount the REFNET header so that it branches horizontally.

4. Pipe connection

- Only use the flare nuts included with the unit.  
Using different flare nuts may cause the refrigerant to leak.
- Be sure to perform a nitrogen blow when brazing.  
(Brazing without performing nitrogen replacement or releasing nitrogen into the piping will create large quantities of oxidized film on the inside of the pipes, adversely affecting valves and compressors in the refrigerating system and preventing normal operation.)
- Do not use a flux when brazing the refrigerant pipe joints.  
Use phosphor copper brazing (BCup) which does not require flux.  
(Using a chlorine flux may cause the pipes to corrode, and if it contains fluoride it may cause the refrigerant lubricant to deteriorate, adversely affecting the refrigerant piping system.)



**Note:**

- The pressure regulator for the nitrogen released when doing the brazing should be set to 2.9 psi or less.

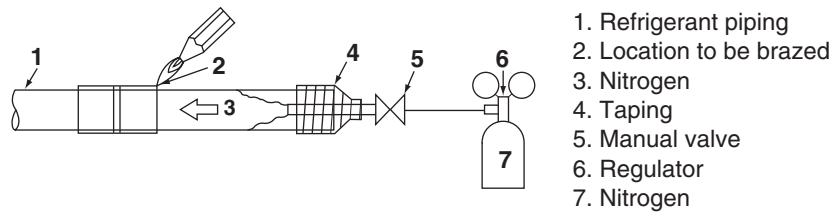

5. Protection against contamination when installing pipes

- Take measures to prevent foreign materials like moisture and contamination from mixing into the system.

Place	Installation period	Protection method
Outdoor	More than a month	Pinch the pipe
	Less than a month	Pinch of tape the pipe
Indoor	Regardless of the period	

- Great caution is needed when passing copper tubes through walls.

**Precautions when selecting branch piping.**

- If the piping between the outdoor unit and the first refrigerant branching kit is 295ft. or longer, be sure to enlarge the main pipe in the liquid-side piping.  
Do not enlarge the main pipe in the discharge-side and suction-side piping.  
Depending on the length of the refrigerant piping, the power may drop, but even in such cases it is ok to enlarge the main pipe.

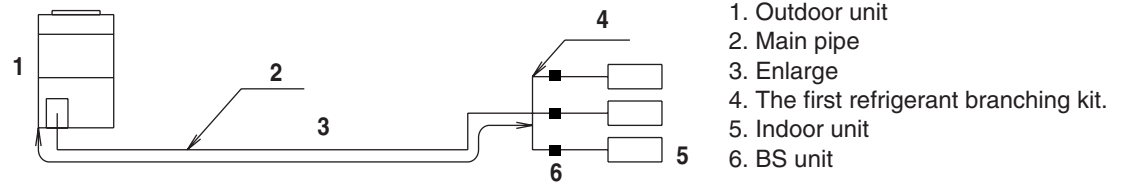

[Liquid side]

REYQ96MTJU type: .....  $\phi 3/8'' \rightarrow \phi 1/2''$



### 6.3 Example of Connection

**Legend:**

- 1 indoor unit
- REFNET joint
- REFNET header

**BS unit connections:**

- (3 pipes) Discharge gas pipe, Suction gas pipe, Liquid pipe
- (2 pipes) Gas pipe, Liquid pipe

Piping from BS unit to indoor Unit and Piping from Refrigerant branch kit to indoor unit used as cooling only must be composed by 2 pipes (Suction Gas pipe and Liquid pipe)

		Branch with refnet joint	Branch with refnet joint and refnet header	Branch with refnet header																																												
<b>One outdoor unit installed</b>																																																
Maximum allowable length	Between outdoor and indoor units	Actual pipe length	Pipe length between outdoor and indoor units ≤ 330ft Example unit 8: a + b + c + d + e + s ≤ 330ft	Example unit 6: a + b + l ≤ 330ft, unit 8: a + m + n + p ≤ 330ft																																												
		Equivalent length	Equivalent pipe length between outdoor and indoor units ≤ 390ft (assume equivalent pipe length of refnet joint to be 1.6ft, that of refnet header to be 3.3ft., that of BSVQ36, 60 to be 13ft calculation purposes)																																													
		Total extension length	Total piping length from outdoor unit* to all indoor units ≤ 950ft																																													
Allowable height length	Between outdoor and indoor units	Difference in height between outdoor and indoor units (H1) ≤ 164ft. (Max 130ft. if the outdoor unit is below)																																														
	Between indoor and indoor units	Difference in height between adjacent indoor units (H2) ≤ 49ft.																																														
Allowable length after the branch	Actual pipe length	Pipe length from first refrigerant branch kit (either refnet joint or refnet header) to indoor unit ≤ 130ft. Example unit 8: b + c + d + e + s ≤ 130ft.	Example unit 6: b + l ≤ 130ft., unit 8: m + n + p ≤ 130ft.	Example unit 8: o ≤ 130ft.																																												
<b>Refrigerant branch kit selection</b>		<p>How to select the refnet joint</p> <ul style="list-style-type: none"> <li>When using refnet joints at the first branch counted from the outdoor unit side.</li> </ul> <table border="1" style="width: 100%; border-collapse: collapse;"> <thead> <tr> <th>Outdoor unit capacity type</th> <th>Refrigerant branch kit name</th> </tr> </thead> <tbody> <tr> <td>REYQ96 type</td> <td>KHRP25M33T</td> </tr> </tbody> </table> <p>For refnet joints other than the first branch, select the proper branch kit model based on the total capacity index.</p> <table border="1" style="width: 100%; border-collapse: collapse;"> <thead> <tr> <th rowspan="2">indoor capacity index</th> <th colspan="2">Refrigerant branch kit name</th> </tr> <tr> <th>In case of 3 pipes</th> <th>In case of 2 pipes</th> </tr> </thead> <tbody> <tr> <td>&lt; 72</td> <td>KHRP25M22T</td> <td>KHRP26M22T</td> </tr> <tr> <td>72 ≤</td> <td>KHRP25M33T</td> <td>KHRP26M33T</td> </tr> </tbody> </table> <p>How to select the refnet header</p> <ul style="list-style-type: none"> <li>Choose from the following table in accordance with the total capacity of all the indoor units connected below the REFNET header.</li> </ul> <table border="1" style="width: 100%; border-collapse: collapse;"> <thead> <tr> <th rowspan="2">indoor capacity index</th> <th colspan="2">Refrigerant branch kit name</th> </tr> <tr> <th>In case of 3 pipes</th> <th>In case of 2 pipes</th> </tr> </thead> <tbody> <tr> <td>&lt; 72</td> <td rowspan="2">KHRP25M33H</td> <td>KHRP26M22H or KHRP26M33H</td> </tr> <tr> <td>72 ≤</td> <td>KHRP26M33H</td> </tr> </tbody> </table>			Outdoor unit capacity type	Refrigerant branch kit name	REYQ96 type	KHRP25M33T	indoor capacity index	Refrigerant branch kit name		In case of 3 pipes	In case of 2 pipes	< 72	KHRP25M22T	KHRP26M22T	72 ≤	KHRP25M33T	KHRP26M33T	indoor capacity index	Refrigerant branch kit name		In case of 3 pipes	In case of 2 pipes	< 72	KHRP25M33H	KHRP26M22H or KHRP26M33H	72 ≤	KHRP26M33H																			
Outdoor unit capacity type	Refrigerant branch kit name																																															
REYQ96 type	KHRP25M33T																																															
indoor capacity index	Refrigerant branch kit name																																															
	In case of 3 pipes	In case of 2 pipes																																														
< 72	KHRP25M22T	KHRP26M22T																																														
72 ≤	KHRP25M33T	KHRP26M33T																																														
indoor capacity index	Refrigerant branch kit name																																															
	In case of 3 pipes	In case of 2 pipes																																														
< 72	KHRP25M33H	KHRP26M22H or KHRP26M33H																																														
72 ≤		KHRP26M33H																																														
Example of downstream indoor units		example in case of refnet joint C; indoor units 5 + 6 + 7 + 8	example in case of refnet joint B indoor units 7 + 8, example in case of refnet header; indoor units 1 + 2 + 3 + 4 + 5 + 6	example in the case of refnet header; indoor units 1 + 2 + 3 + 4 + 5 + 6 + 7 + 8																																												
<b>Pipe size selection</b>		<p>Piping between outdoor unit and refrigerant branch kit</p> <ul style="list-style-type: none"> <li>Match to the size of the connection piping on the outdoor unit.</li> </ul> <table border="1" style="width: 100%; border-collapse: collapse;"> <thead> <tr> <th rowspan="3">Outdoor unit capacity type</th> <th colspan="3">Piping size (outer diameter) (Unit:in.)</th> </tr> <tr> <th rowspan="2">Liquid pipe</th> <th colspan="2">Gas pipe</th> </tr> <tr> <th>Suction</th> <th>Discharge</th> </tr> </thead> <tbody> <tr> <td>REYQ96 type</td> <td>φ3/8</td> <td>φ7/8</td> <td>φ3/4</td> </tr> </tbody> </table> <p>Between two immediately adjacent refrigerant branch kits and BS unit</p> <ul style="list-style-type: none"> <li>Choose from the following table in accordance with the total capacity of all the indoor units connected below this.</li> <li>Do not let the connection piping exceed the refrigerant piping size chosen by general system model name.</li> </ul> <table border="1" style="width: 100%; border-collapse: collapse;"> <thead> <tr> <th rowspan="3">indoor capacity index</th> <th colspan="3">Piping size (outer diameter) (Unit:in.)</th> </tr> <tr> <th rowspan="2">Liquid pipe</th> <th colspan="2">Gas pipe</th> </tr> <tr> <th>Suction</th> <th>Discharge</th> </tr> </thead> <tbody> <tr> <td>* 1 &lt; 24</td> <td>φ1/4</td> <td>φ1/2</td> <td>φ3/8</td> </tr> <tr> <td>* 2 24 ≤ x &lt; 72</td> <td rowspan="2">φ3/8</td> <td>φ5/8</td> <td>φ1/2</td> </tr> <tr> <td>72</td> <td>φ7/8</td> <td>φ3/4</td> </tr> </tbody> </table> <p>Between BS unit (refrigerant branch kit) and indoor unit</p> <ul style="list-style-type: none"> <li>Pipe size for direct connection to indoor unit must be the same as the connection size of indoor unit.</li> </ul> <table border="1" style="width: 100%; border-collapse: collapse;"> <thead> <tr> <th rowspan="2">indoor capacity index</th> <th colspan="2">Piping size (outer diameter) (Unit:in.)</th> </tr> <tr> <th>Gas pipe</th> <th>Liquid pipe</th> </tr> </thead> <tbody> <tr> <td>* 1 12, 18 type</td> <td>1/2</td> <td>1/4</td> </tr> <tr> <td>24, 30, 36, 48 type</td> <td>5/8</td> <td>3/8</td> </tr> </tbody> </table> <p>* 1 The BS unit (BSVQ36MVJU) port and connection pipe are different sizes. Use the reducing joints included with the BS unit. * 2 When the indoor capacity is 60 ≤ x &lt; 72, use the attached pipes included with BS unit.</p>			Outdoor unit capacity type	Piping size (outer diameter) (Unit:in.)			Liquid pipe	Gas pipe		Suction	Discharge	REYQ96 type	φ3/8	φ7/8	φ3/4	indoor capacity index	Piping size (outer diameter) (Unit:in.)			Liquid pipe	Gas pipe		Suction	Discharge	* 1 < 24	φ1/4	φ1/2	φ3/8	* 2 24 ≤ x < 72	φ3/8	φ5/8	φ1/2	72	φ7/8	φ3/4	indoor capacity index	Piping size (outer diameter) (Unit:in.)		Gas pipe	Liquid pipe	* 1 12, 18 type	1/2	1/4	24, 30, 36, 48 type	5/8	3/8
Outdoor unit capacity type	Piping size (outer diameter) (Unit:in.)																																															
	Liquid pipe	Gas pipe																																														
		Suction	Discharge																																													
REYQ96 type	φ3/8	φ7/8	φ3/4																																													
indoor capacity index	Piping size (outer diameter) (Unit:in.)																																															
	Liquid pipe	Gas pipe																																														
		Suction	Discharge																																													
* 1 < 24	φ1/4	φ1/2	φ3/8																																													
* 2 24 ≤ x < 72	φ3/8	φ5/8	φ1/2																																													
72		φ7/8	φ3/4																																													
indoor capacity index	Piping size (outer diameter) (Unit:in.)																																															
	Gas pipe	Liquid pipe																																														
* 1 12, 18 type	1/2	1/4																																														
24, 30, 36, 48 type	5/8	3/8																																														
<b>How to calculate the additional refrigerant to be charged</b>		<p>Additional refrigerant to be charged R (lb.) R should be rounded off in units of 0.1lb.</p> <p>NOTE: If a negative result is gotten for R from the formula at right, no refrigerant needs to be added.</p> $R = \left\{ \left( \frac{\text{Total length (ft.) of liquid piping size at } \phi 1/2}{\text{Total length (ft.) of liquid piping size at } \phi 3/8} \right) \times 0.074 + \left( \frac{\text{Total length (ft.) of liquid piping size at } \phi 3/8}{\text{Total length (ft.) of liquid piping size at } \phi 1/4} \right) \times 0.036 + \left( \frac{\text{Total length (ft.) of liquid piping size at } \phi 1/4}{\text{Total length (ft.) of liquid piping size at } \phi 1/4} \right) \times 0.015 \right\} \times 1.15$ <p>Example for refrigerant branch using refnet joint and refnet header</p> <p>If the piping lengths are as at right</p> <table border="1" style="width: 100%; border-collapse: collapse;"> <tr> <td>a: φ3/8 × 100ft.</td> <td>d: φ1/4 × 30ft.</td> <td>g: φ1/4 × 30ft.</td> <td>j: φ1/4 × 30ft.</td> </tr> <tr> <td>b: φ3/8 × 30ft.</td> <td>e: φ1/4 × 30ft.</td> <td>h: φ1/4 × 70ft.</td> <td>k: φ1/4 × 25ft.</td> </tr> <tr> <td>c: φ1/4 × 30ft.</td> <td>f: φ1/4 × 30ft.</td> <td>i: φ3/8 × 30ft.</td> <td></td> </tr> </table> $R = \left\{ [a+b+i \times 0.036] + [c+d+e+f+g+h+j+k \times 0.015] \right\} \times 1.15 = 11.37 \Rightarrow 11.4$			a: φ3/8 × 100ft.	d: φ1/4 × 30ft.	g: φ1/4 × 30ft.	j: φ1/4 × 30ft.	b: φ3/8 × 30ft.	e: φ1/4 × 30ft.	h: φ1/4 × 70ft.	k: φ1/4 × 25ft.	c: φ1/4 × 30ft.	f: φ1/4 × 30ft.	i: φ3/8 × 30ft.																																	
a: φ3/8 × 100ft.	d: φ1/4 × 30ft.	g: φ1/4 × 30ft.	j: φ1/4 × 30ft.																																													
b: φ3/8 × 30ft.	e: φ1/4 × 30ft.	h: φ1/4 × 70ft.	k: φ1/4 × 25ft.																																													
c: φ1/4 × 30ft.	f: φ1/4 × 30ft.	i: φ3/8 × 30ft.																																														



## 6.4 Leak Test and Vacuum Drying

The units were checked for leaks by the manufacturer.

Confirm that the valves are firmly closed before pressure test or vacuuming.

To prevent entry of any impurities and ensure sufficient pressure resistance, always use the special tools dedicated for R410A.

Air tight test and vacuum drying

- Air tight test: Make sure to use nitrogen gas.

(For the service port location, refer to the "Caution" label attached on the front panel [right] of the outdoor unit.)

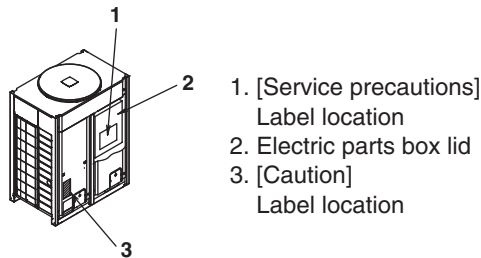

Pressurize the liquid, suction gas and discharge gas pipes to 551 psi (do not pressurize more than 551 psi). If the pressure does not drop within 24 hours, the system passes the test. If the pressure drops, check where the nitrogen leaks from.

- Vacuum drying: Use a vacuum pump which can evacuate to -14.6 psi.
  1. Evacuate the system from the liquid, suction gas and discharge gas pipes by using a vacuum pump for more than 2 hours and bring the system to -14.6 psi. After keeping the system under that condition for more than 1 hour, check if the vacuum gauge rises or not. If it rises, the system may either contain moisture inside or have leaks.
  2. Following should be executed if there is a possibility of moisture remaining inside the pipe (if piping work is carried out during the raining season or over a long period of time rainwater may enter the pipe during work).  
After evacuating the system for 2 hours, pressurize the system to 7.25psi (vacuum break) with nitrogen gas and evacuate the system again using the vacuum pump for 1 hour to -14.6 psi (vacuum drying). If the system cannot be evacuated to -14.6 psi within 2 hours, repeat the operation of vacuum break and vacuum drying.  
Then, after leaving the system in vacuum for 1 hour, confirm that the vacuum gauge does not rise.



**Note:** Make sure to perform air tight test and vacuum drying using the service ports of the shutoff valve shown in the table below.

One outdoor unit installed: In case of REYQ96MTJU	Liquid line shutoff valve Discharge gas line shutoff valve Suction gas line shutoff valve
--	---

### Shutoff valve operation procedure

Introduction

Confirm the sizes of the shutoff valves connected to the system referring to the table below.

	Q96 type
Liquid line shutoff valve	φ3/8"
Suction gas line shutoff valve	φ7/8"
Discharge gas line shutoff valve	φ3/4"

**Opening shutoff valve**

1. Remove the cap and turn the valve counterclockwise with the hexagon wrench.
2. Turn it until the shaft stops.  
Do not apply excessive force to the shutoff valve. Doing so may break the valve body, as the valve is not a backseat type. Always use the special tool.
3. Make sure to tighten the cap securely.

**Closing shutoff valve**

1. Remove the cap and turn the valve clockwise with the hexagon wrench.
2. Securely tighten the valve until the shaft contacts the main body seal.
3. Make sure to tighten the cap securely.
  - For the tightening torque, refer to the table below.

**Tightening torque**

Shutoff valve size	Tightening torque ft.-lbf (Turn clockwise to close)					
	Shaft (valve body)		Cap (valve lid)	Service port	Flare nut	Suction gas line piping attached to unit (1)
φ3/8"	3.98-4.87	Hexagon wrench 0.16 in.	9.96-12.17	8.48-10.25	24.1-29.4	—
φ3/4"	9.96-12.17	Hexagon wrench 0.24 in.	17.33-20.28		71.55-87.77	—
φ7/8"	19.91-24.34	Hexagon wrench 0.39 in.	26.55-32.45		—	16.23-20.65

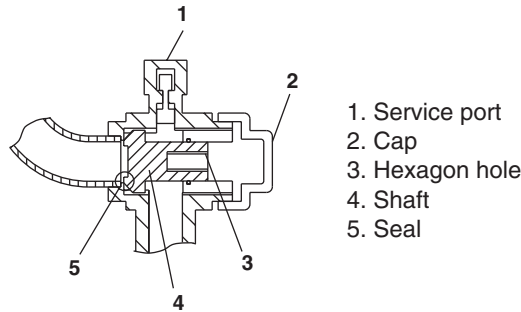

**CAUTION**

- Always use a charge hose for service port connection.
- After tightening the cap, check that no refrigerant leaks are present.
- When loosening a flare nut, always use two wrenches in combination. When connecting the piping, always use a spanner and torque wrench in combination to tighten the flare nut.
- When connecting a flare nut, coat the flare (inner and outer faces) with ether oil or ester oil and hand-tighten the nut 3 to 4 turns as the initial tightening.

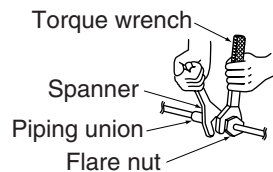



**FLARE SHAPE and FLARENUT TIGHTENING TORQUE**

<Precautions when connecting pipes>

- See the following table for flare part machining dimensions.
- When connecting the flare nuts, apply refrigerant oil to the inside and outside of the flares and turn them three or four times at first. (Use ester oil or ether oil.)
- See the following table for tightening torque.  
(Applying too much torque may cause the flares to crack.)
- After all the piping has been connected, use nitrogen to perform a gas leak check.

pipe size (in.)	tightening torque (ft.-lbf)	A (in.)	flare shape (in.)
φ3/8"	24.1 - 29.4	0.504 - 0.520	
φ1/2"	36.5 - 44.5	0.638 - 0.654	
φ5/8"	45.6 - 55.6	0.760 - 0.776	

**Not recommendable but in case of emergency**

You must use a torque wrench but if you are obliged to install the unit without a torque wrench, you may follow the installation method mentioned below.

**After the work is finished, make sure to check that there is no gas leak.**

When you keep on tightening the flare nut with a spanner, there is a point where the tightening torque suddenly increases. From that position, further tighten the flare nut the angle shown below:  
(in.)

Pipe size	Further tightening angle	Recommended arm length of tool
φ3/8"	60 to 90 degrees	Approx. 7 7/8
φ1/2"	30 to 60 degrees	Approx. 9 13/16
φ5/8"	30 to 60 degrees	Approx. 11 13/16
φ3/4"	20 to 35 degrees	Approx. 17 3/4

**Disposal requirements**

Dismantling of the unit, treatment of the refrigerant, oil and eventual other parts, should be done in accordance with the relevant local and national regulations.

## 6.5 Pipe Insulation

After finishing the leak test and vacuum drying, the piping must be insulated. Take into account the following points:

- Make sure to insulate the connection piping and refrigerant branch kits entirely.
- Be sure to insulate the liquid-side, suction gas-side and discharge gas-side piping for the inter-unit piping and the refrigerant branch kits.  
Not insulating them may cause leaking. (The gas piping can reach temperatures of 250°F. Be sure the insulation used can withstand such temperatures.)
- If you think the humidity around the cooling piping might exceed 86°F and RH80%, reinforce the insulation on the cooling piping (at least 13/16" thick). Condensation might form on the surface of the insulation.
- If there is a possibility that condensation on the shut-off valve might drip down into the indoor unit through gaps in the insulation and piping because the outdoor unit is located higher than the indoor unit, etc., this must be prevented by caulking the connections, etc.

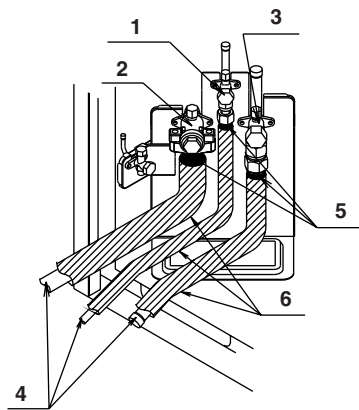

1. Liquid line shutoff valve
2. Suction gas line shutoff valve
3. Discharge gas line shutoff valve
4. Outer-to-inner interconnecting piping
5. Caulking treatment, etc.
6. Heat insulator



**CAUTION** Be sure to insulate local pipes, as touching them can cause burns.

## 6.6 Additional Refrigerant Charge



**CAUTION** Refrigerant cannot be charged until field wiring has been completed. Refrigerant may only be charged after performing the leak test and the vacuum drying (see above). When charging a system, care shall be taken that its maximum permissible charge is never exceeded, in view of the danger of liquid hammer. Charging with an unsuitable substance may cause explosions and accidents, so always ensure that the appropriate refrigerant (R410A) is charged. Refrigerant containers shall be opened slowly. Always use protective gloves and protect your eyes when charging refrigerant.

**TO AVOID COMPRESSOR BREAKDOWN. DO NOT CHARGE THE REFRIGERANT MORE THAN THE SPECIFIED AMOUNT TO RAISE THE CONDENSING PRESSURE.**

- This outdoor unit is factory charged with refrigerant and depending on pipe sizes and pipe lengths some systems require additional charging of refrigerant.
- Charge the refrigerant to the liquid pipe in its liquid state. Since R410A is a mixed refrigerant, its composition changes if charged in a state of gas and normal system operation would no longer be assured.
- Before filling, check whether the tank has a siphon attached or not.

**How to fill a tank with a siphon attached.**

Fill with the tank upright. (There is a siphon tube inside, so there is no need to turn the tank upside-down.)

**Other ways of filling the tank**

Fill with the tank upside-down.



- Determine the amount of refrigerant to be added by referring to the table, write it down on the included “Added Refrigerant” plate and attach it to the rear side of the front cover.  
Note: refer to the example of connection for the amount to be added.
- After the vacuum drying is finished, charge the additional refrigerant in its liquid state through the liquid shutoff valve service port.  
Taking into account following instructions:
  1. Check that gas and liquid shutoff valves are closed.
  2. Charge the specified weight of refrigerant.
- If the outdoor unit is not in operation and the total amount cannot be charged, follow the procedures for additional refrigerant charge shown below.
- Make sure to use installation tools you exclusively use on R410A installations to withstand the pressure and to prevent foreign materials from mixing into the system.

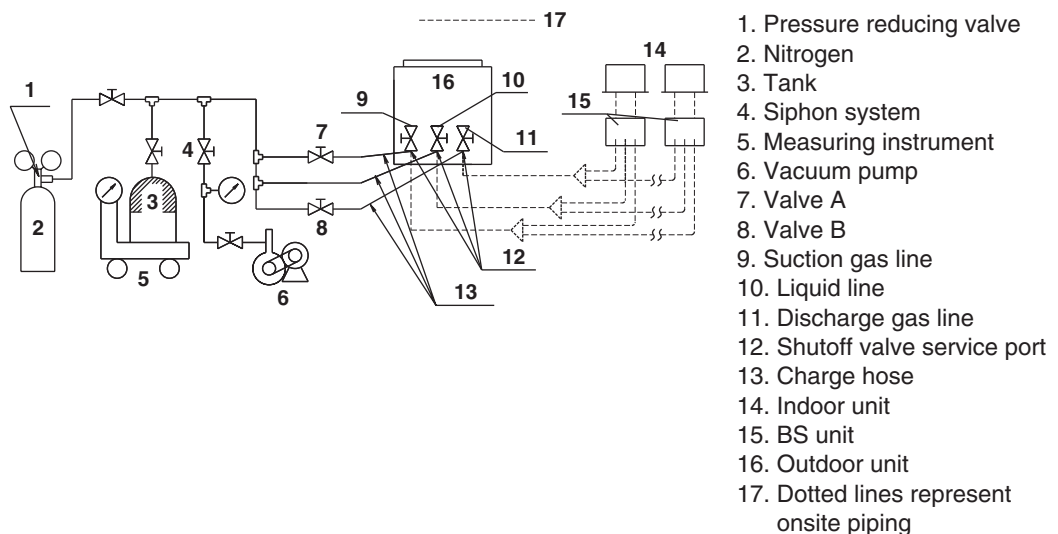

**Note:** ■ Procedures for charging additional refrigerant.

**One outdoor unit installed:**

**[Additional refrigerant charge procedure]**

To learn the system settings for additional refrigerant charging, refer to the [Service Precaution] label attached on the back of the electric box lid in the outdoor unit.

1. Fully open the suction gas line and discharge gas line shutoff valves (liquid line shutoff valve and valve A and valve B above must be left fully closed) and start the additional refrigerant charge operation.
2. After the system is charged with a specified amount of refrigerant, press the confirmation button (BS3) on the PC-board (A1P) in the outdoor unit to stop the additional refrigerant charge operation.
3. Immediately restore the shutoff valve to the following status. (The test run cannot be performed properly if the shut-off valve is not correct.)

Liquid line shutoff valve	Suction gas line shutoff valve	Discharge gas line shutoff valve	Oil-equalizing line shutoff valve
Open	Open	Open	Close (Default status before delivery)

**CAUTION**

If the refrigerant cylinder is siphonal, set it upright while charging additional refrigerant.

## 7. Field Wiring



### CAUTION

All field wiring and components must be installed by a licensed electrician and must comply with relevant local and national regulations.

The field wiring must be carried out in accordance with the wiring diagrams and the instructions given below.

Be sure to use a dedicated power circuit. Never use a power supply shared by another appliance.

This product's reversed phase protection detector only works when the product started up.

The reversed phase protection detector is designed to stop the product in the event of an abnormalities when the product is started up.

Replace two of the three phases (L1, L2, and L3) during reverse-phase protection circuit operation.

Reversed phase detection is not performed while the product is operating.

If there exists the possibility of reversed phase after an momentary black out and the power goes on and off while the product is operating, attach a reversed phase protection circuit locally.

Running the product in reversed phase can break the compressor and other parts.

### 7.1 Optional Parts



#### Note:

- Use copper conductors only.
- When using the adaptor for sequential start, refer to chapter “Examples”.
- For connection wiring to outdoor-outdoor transmission F1-F2, outdoor-indoor transmission F1-F2, refer to chapter “Examples”.
- For connection wiring to the central remote controller, refer to the installation manual of the central remote controller.
- Use insulated wire for the power cord.

### 7.2 Power Circuit and Cable Requirements

A power circuit (see table below) must be provided for connection of the unit. This circuit must be protected with the required safety devices, i.e. a main switch, a slow blow fuse on each phase and an earth leak detector.

	Phase and frequency	Voltage	Recommended fuses
REYQ96MTJU	$\phi 3$ , 60Hz	208-230V	70A

When using residual current operated circuit breakers, be sure to use a high-speed type 200mA rated residual operating current.



#### Note:

- Select the power supply cable in accordance with relevant local and national regulations.
- Wire size must comply with the applicable local and national code.
- Specifications for local wiring power cord and branch wiring are in compliance with local cord.

## 7.3 General

- Make sure to connect the power supply wire to the power supply terminal block and to clamp it as shown in figure 14, chapter "Field line connection".
- As this unit is equipped with an inverter, installing a phase advancing capacitor not only will deteriorate power factor improvement effect, but also may cause capacitor abnormal heating accident due to high-frequency waves. Therefore, never install a phase advancing capacitor.
- Keep power imbalance within 2% of the supply rating.
  1. Large imbalance will shorten the life of the smoothing capacitor.
  2. As a protective measure, the product will stop operating and an error indication will be made, when power imbalance exceeds 4% of the supply rating.
- Follow the "electrical wiring diagram" when carrying out any electrical wiring.
- Only proceed with wiring work after blocking off all power.
- Always ground wires. (In accordance with national regulations of the pertinent country.)
- Do not connect the ground wire to gas pipes, sewage pipes, lightning rods, or telephone ground wires.
  - Gas pipes: can explode or catch fire if there is a gas leak.
  - Sewage pipes: no grounding effect is possible if hard plastic piping is used.
  - Telephone ground wires and lightning rods: dangerous when struck by lightning due to abnormal rise in electrical potential in the grounding.
- This unit uses an inverter, and therefore generates noise, which will have to be reduced to avoid interfering with other devices. The outer casing of the product may take on an electrical charge due to leaked electrical current, which will have to be discharged with the grounding.
- Be sure to install an earth leak detector. (One that can handle higher harmonics.)  
(This unit uses an inverter, which means that an earth leak detector capable handling high harmonics in order to prevent malfunctioning of the earth leak detector itself.)
- Earth leak detector which is especially for protecting ground-faults should be used in conjunction with main switch or fuse for use with wiring.
- This unit has a negative phase protection circuit. (If it operates, only operate the unit after correcting the wiring.)

## 7.4 Examples

### System example

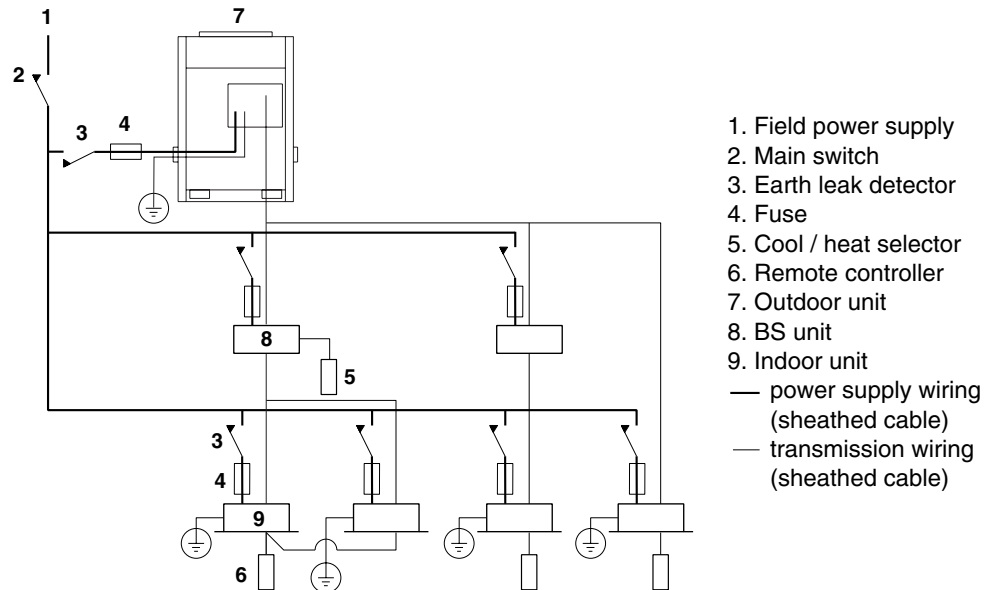

### Field line connection

L1, L2, L3, phase of the power supply wiring should be clamped to the safetycatch using the included clamp material.

The green and yellow striped wrapped wires should be used for grounding.

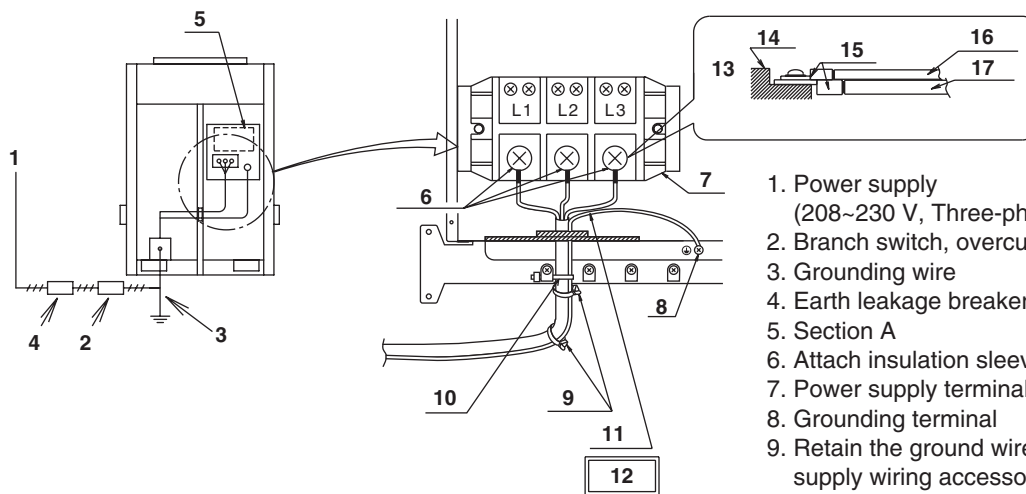

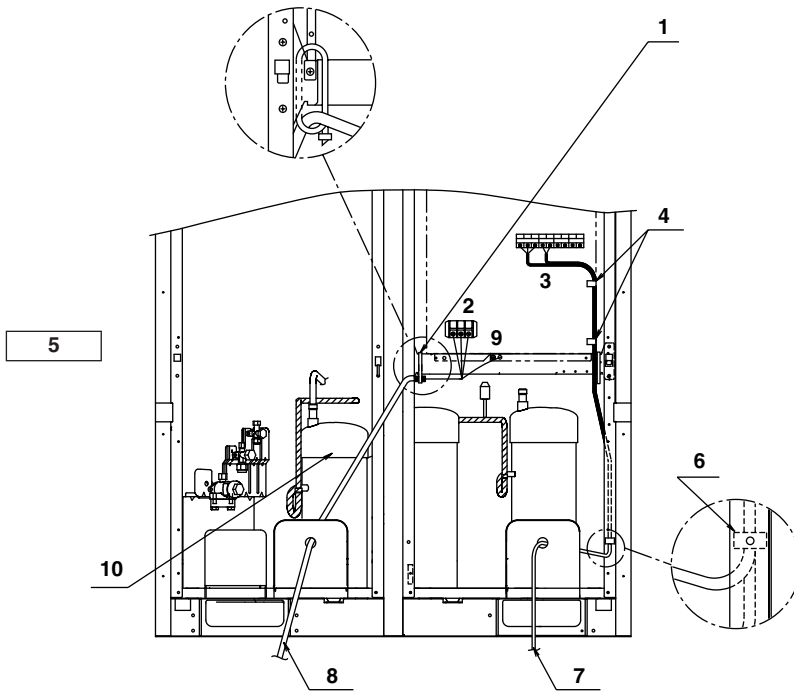

1. Retain with accessory clamp (3).
2. Electric wiring
3. Wiring between units
4. Retain to the electric parts box with the accessory clamps (1).
5. When routing the remote control cord and inter-unit wiring, secure clearance of 5 " or more from the power wiring. Ensure that the power wiring does not contact any heated sections ( ).
6. Retain to the back of the column support with the accessory clamp (2).
7. Inter-unit wirings
8. Power/ground wires
9. Grounding wire
10. When wiring, exercise sufficient caution not to detach the acoustic insulators from the compressor.



**CAUTION <Precautions when laying power wiring>**

Use round pressure terminals for connections to the power terminal block. When none is available, follow the instructions below.

- Do not connect wiring of different thicknesses to the power terminal block. (Slack in the power wiring may cause abnormal heat.)
- When connecting wiring which is the same thickness, do as shown in the figure below.

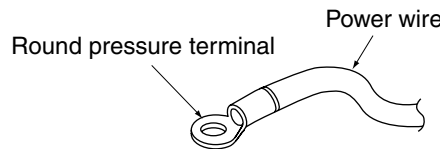

Connect same-thickness wiring to both sides.

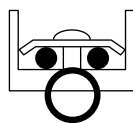

It is forbidden to connect two to one side.

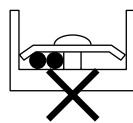

It is forbidden to connect wiring of different thicknesses.

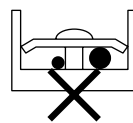

- For wiring, use the designated power wire and connect firmly, then secure to prevent outside pressure being exerted on the terminal board.
- Use an appropriate screwdriver for tightening the terminal screws. A screwdriver with a small head will strip the head and make proper tightening impossible.
- Over-tightening the terminal screws may break them.
- See the table below for tightening torque for the terminal screws.

Tightening torque (ft. lbf)	
M8 (Power terminal block)	4.06-5.38
M8 (Ground)	
M3 (Inter-unit wiring terminal block)	0.59-0.72



**<Precautions when connecting the ground>**

When pulling the ground wire out, wire it so that it comes through the cut out section of the cup washer. (An improper ground connection may prevent a good ground from being achieved.)

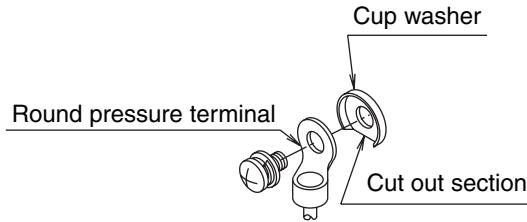

**Field line connection: transmission wiring**

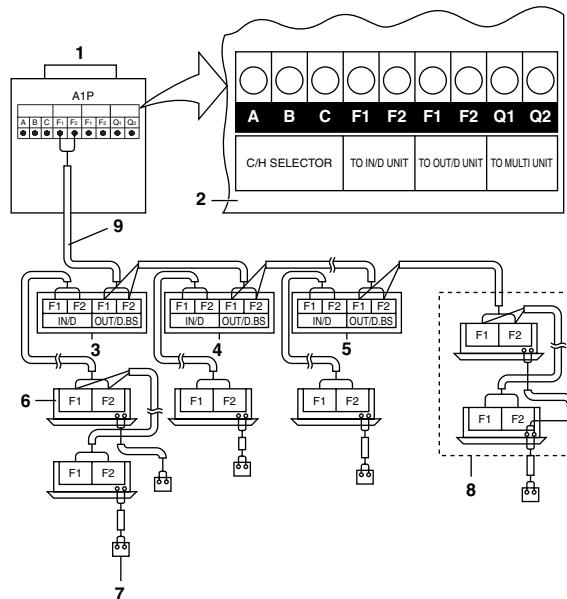

1. Outdoor unit
2. Outdoor unit P.C. board (A1P)
3. BS unit A
4. BS unit B
5. Last BS unit
6. Indoor unit
7. Remote controller
8. Cool-only unit
9. Use the conductor of sheathed wire (2 wire) (no polarity)



**CAUTION**

Be sure to follow the limits below. If the unit-to-unit cables are beyond these limits, it may result in malfunction of transmission.  
 Maximum wiring length: 3280ft.  
 Total wiring length: 6560ft.  
 Max branches No. of branches: 16  
 Max. number of outdoor units connectable: 10 or less  
 Up to 16 branches are possible for unit-to unit cabling. No branching is allowed after branching.  
 Never connect the power supply to unit-to-unit cabling terminal block. Otherwise the entire system may break down.

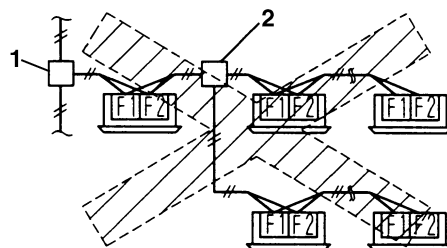

1. Branch
2. Subbranching

**CAUTION**

For low-noise operation, it is necessary to get the optional “External control adaptor for outdoor unit”.

For details, see the installation manual attached to the adaptor.

**Picking power line and transmission line**

- Be sure to let the power line and the transmission line pass through a conduit hole.
- Pick the power line from the upper hole on the front position of the main unit.

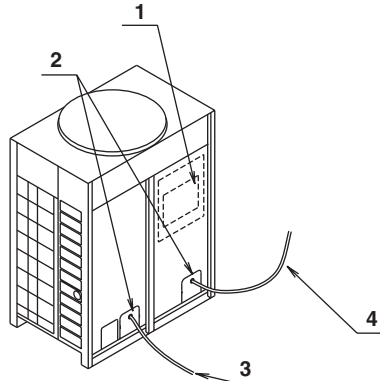

1. Electric wiring diagram  
Printed on the back of the electric parts box lid.
2. Knockout hole
3. Power line
4. Transmission line

**Precautions when knocking out knock holes**

- To punch a knock hole, hit on it with a hammer.
- Open an appropriate hole as needed.
- After knocking out the holes, we recommend you paint the edges and areas around the edges using the repair paint to prevent rusting.
- Power line: Open a knockout hole as shown at left and connect it using a conduit.
- Transmission line: Connect it using a conduit in the knockout hole on the right.

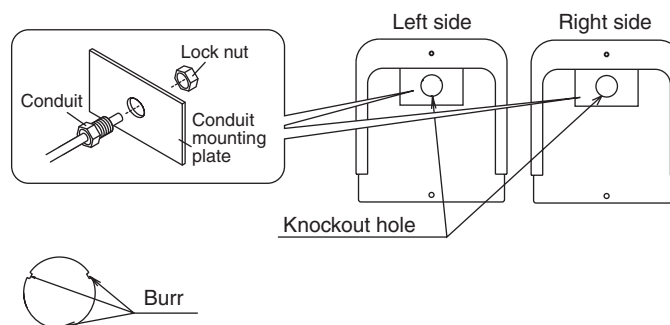
**CAUTION**

- Use a power wire pipe for the power wiring.
- Outside the unit, make sure the low-voltage electric wiring (i.e. for the remote control, between units, etc.) and the high-voltage electric wiring do not pass near each other, keeping them at least 5in. apart. Proximity may cause electrical interference, malfunctions, and breakage.
- Be sure to connect the power wiring to the power wiring terminal block and secure it as described in 7-4 Field line connection.
- Inter-unit wiring should be secured as described in 7-4 Field line connection.
  - Secure the wiring with the accessory clamps so that it does not touch the piping.
  - Make sure the wiring and the electric parts box lid do not stick up above the structure, and close the cover firmly.

Never connect 200 V to the terminal block of the interconnecting wiring. Doing so will break the entire system.

- The wiring from the indoor units must be connected to the F1/F2 (In-Out) terminals on the PC board in the outdoor unit.

For the above wiring, always use vinyl cords with AWG 18-16 sheath or cables (2 core wires).

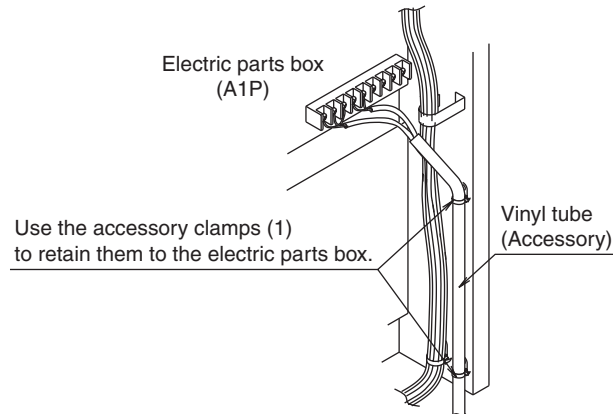
**CAUTION**

Be sure to keep the power line and transmission line apart from each other.

Be careful about polarity of the transmission line.

Make sure that the transmission line is clamped as shown in the figure in chapter "Field line connection".

Check that wiring lines do not make contact with refrigerant piping.

Firmly close the lid and arrange the electric wires so as to prevent the lid or other parts from coming loose.

## 8. Before Operation

### 8.1 Checks Before Initial Start-up

**CAUTION**

Make sure that the circuit breaker on the power supply panel of the installation is switched off. Attach the power wire securely.

After the installation, check the following before switching on the circuit breaker:

1. The position of the switches that require an initial setting  
Make sure that switches are set according to your application needs before turning the power supply on.
2. Power supply wiring and transmission wiring  
Use a designated power supply and transmission wiring and make sure that it has been carried out according to the instructions described in this manual, according to the wiring diagrams and according to local and national regulations.
3. Pipe sizes and pipe insulation  
Make sure that correct pipe sizes are installed and that the insulation work is properly executed.
4. Additional refrigerant charge  
The amount of refrigerant to be added to the unit should be written on the included "Added Refrigerant" plate attached to the rear side of the front cover.
5. Insulation test of the main power circuit  
Using a megatester for 500V, check that the insulation resistance of  $2M\Omega$  or more is attained by applying a voltage of 500V DC between power terminals and earth. Never use the megatester for the transmission wiring.
6. Installation date  
Be sure to keep record of the installation date on the sticker on the electric parts box lid accordingly.

## 8.2 Test Run



**CAUTION** After completing installation, be sure to open the valve. (Operating the unit with the valve shut will break the compressor.)

### Power supply connection

When running the unit for the first time after installation, be sure to perform a test run following these steps. (Not performing a test run when the unit is first installed may prevent the unit from operating properly.)

- During the operation, monitor the outdoor unit operation status and check for any incorrect wiring.

1. Turn ON the power to the outdoor units and indoor units.		Make sure to turn ON the power 6 hours before starting the operation. This is necessary to warm the crankcase preliminarily by the electric heater.							
2. Check the LED on the PC-board (A1P) in the outdoor unit to see if the data transmission is performed normally.									
LED display (Default status before delivery)	Microcomputer operation monitor	Page	Ready/Error	Cooler/heater changeover			Low noise	Demand	Multi
	HAP	H1P	H2P	Individual	Bulk (parent)	Bulk (child)			
One outdoor unit installed	●	●	●	○	●	●	●	●	●
LED display: ● OFF ○ ON ● Blinking									
3. As necessary, configure the system settings onsite by using the dipswitch (DS1) on the outdoor unit PC-board (A1P) and push button switches (BS1 to 5).				Always perform configuration after turning ON the power. To learn the setting method, refer to the [Service Precautions] label attached at the position shown in the figure on the right (Electric box lid in outdoor unit). (Remember, the actual settings you have made must be recorded on the [Service Precautions] label.)					
4. Check if the shutoff valves are in appropriate status and correct any wrong status. (Refer to the table in "6-6 Additional Refrigerant Charge".)				<div style="border: 1px solid black; padding: 2px; display: inline-block;">Caution</div> Do not leave any shutoff valve closed. Otherwise the compressor will fail.					
5. Perform the check operation following the instructions printed on the [Service Precaution] label.				The system operates for about 15 minutes (30 minutes at maximum) and automatically stops the test operation. The system can start a normal operation about 15 minutes after the test operation, only if the remote controller displays no error codes.					

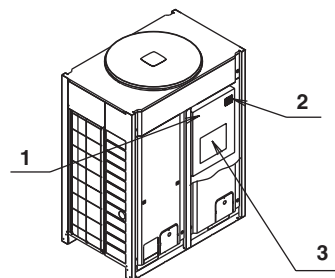

1. Electric box lid
2. Service lid
3. [Service precautions] Label location

**<Cautions for check operation>**

- If the system is started within about 12 minutes after the outdoor/ indoor units are turned ON, the compressor will not run and H2P lights up. Before starting an operation, always verify that the LED display shows the contents of the table in “8-2 Test run 2.”
- The system may require up to 10 minutes until it can start the compressor after an operation start. This is a normal operation to equalize the refrigerant distribution.
- The check operation does not provide any means of checking the indoor units individually. For that purpose, perform normal operation using the remote controller after the check operation.

**Remote controller displays an error:**

Installation error	Malfunction code	Remedial action
The shutoff valve of an indoor unit is left closed.	E3 E4 F3 UF	Check referring to the table in “6-6 Additional Refrigerant Charge”.
The phases of the power to the outdoor units are reversed.	U1	Exchange two of the three phases (L1, L2, L3) to make a positive phase connection.
No power is supplied to an outdoor or indoor unit (including phase interruption).	U1 U4	Check if the power wiring for the outdoor units are connected correctly. (If the power wire is not connected to L2 phase, no malfunction display will appear and the compressor will not work.)
Incorrect interconnections between units	UF	Check if the refrigerant line piping and the unit wiring are consistent with each other.
Refrigerant overcharge	E3 F6 UF	Recalculate the required amount of refrigerant from the piping length and correct the refrigerant charge level by recovering any excessive refrigerant with a refrigerant recovery machine.
Insufficient refrigerant	E4 F3	<ul style="list-style-type: none"> <li>■ Check if the additional refrigerant charge has been finished correctly.</li> <li>■ Recalculate the required amount of refrigerant from the piping length and add an adequate amount of refrigerant.</li> </ul>
If an outdoor multi terminal is connected when there is one outdoor unit installed	U7 UF	Remove the line from the outdoor multi terminals (Q1 and Q2).

**Temperature adjustment operation confirmation**

- After the test run is over, operate the unit normally. (Heating is not possible if the outdoor temperature is 75°F or higher.)
  - Make sure the indoor and outdoor units are operating normally (If a knocking sound can be heard in the liquid compression of the compressor, stop the unit immediately and then energize the heater for a sufficient length of time before restarting the operation.)
  - Run each indoor unit one at a time and make sure the corresponding outdoor unit is also running.
  - Check to see if cold (or hot) air is coming out of the indoor unit.
  - Press the fan direction and fan strength buttons on the indoor unit to see if they operate properly.

**CAUTION****<Cautions for normal operation check>**

- Once stopping, the compressor will not restart in about 5 minutes even if the Run/Stop button of an indoor unit in the same system is pressed.
- When the system operation is stopped by the remote controller, the outdoor units may continue operating for further 5 minutes at maximum.
- If the system has not undergone any check operation by the test operation button since it was first installed, an error code “U3” is displayed. In this case, perform check operation referring to “8-2 Test run”.
- After the test run, when handing the unit over to the customer, make sure the electric box lid, the service lid, and the unit casing are all attached.

## 9. Caution for Refrigerant Leaks

(Points to note in connection with refrigerant leaks)

### Introduction

The installer and system specialist shall secure safety against leakage according to local regulations or standards. The following standards may be applicable if local regulations are not available.

The VRV System, like other air conditioning systems, uses R410A as refrigerant. R410A itself is an entirely safe non-toxic, non-combustible refrigerant. Nevertheless care must be taken to ensure that air conditioning facilities are installed in a room which is sufficiently large. This assures that the maximum concentration level of refrigerant gas is not exceeded, in the unlikely event of major leak in the system and this in accordance to the local applicable regulations and standards.

### Maximum concentration level

The maximum charge of refrigerant and the calculation of the maximum concentration of refrigerant is directly related to the humanly occupied space in to which it could leak.

The unit of measurement of the concentration is  $\text{lb}/\text{ft}^3$  (the weight in lb. of the refrigerant gas in  $1\text{ft}^3$  volume of the occupied space).

Compliance to the local applicable regulations and standards for the maximum allowable concentration level is required.

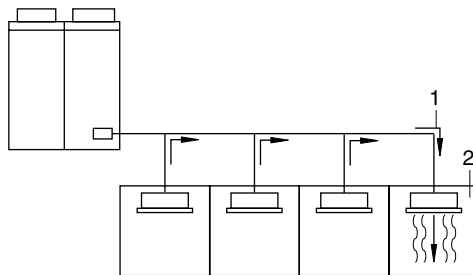

1. direction of the refrigerant flow
2. room where refrigerant leak has occurred (outflow of all the refrigerant from the system)

**Pay a special attention to the place, such as a basement, etc. where refrigerant can stay, since refrigerant is heavier than air.**

### Procedure for checking maximum concentration

Check the maximum concentration level in accordance with steps 1 to 4 below and take whatever action is necessary to comply.

1. Calculate the amount of refrigerant (lb.) charged to each system separately.

amount of refrigerant in a single unit system (amount of refrigerant with which the system is charged before leaving the factory)	+	additional charging amount (amount of refrigerant added locally in accordance with the length or diameter of the refrigerant piping)	=	total amount of refrigerant (lb.) in the system
---	---	--	---	---



**Note:** ■ Where a single refrigerant facility is divided into 2 entirely independent refrigerant systems then use the amount of refrigerant with which each separate system is charged.

2. Calculate the smallest room volume (ft<sup>3</sup>)  
In case like the following, calculate the volume of (A), (B) as a single room or as the smallest room.

A. Where there are no smaller room divisions

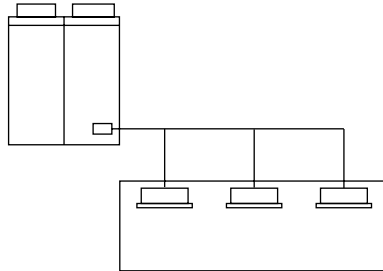

B. Where there is a room division but there is an opening between the rooms sufficiently large to permit a free flow of air back and forth.

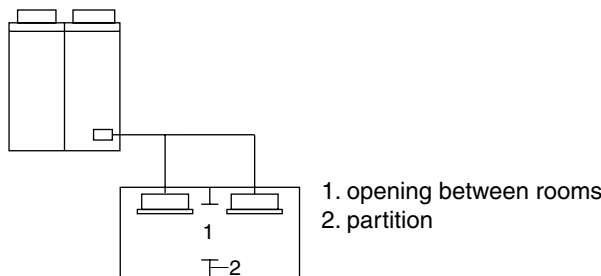

(Where there is an opening without a door or where there are openings above and below the door which are each equivalent in size to 0.15% or more of the floor area.)

3. Calculating the refrigerant density using the results of the calculations in steps 1 and 2 above.

$$\frac{\text{total volume of refrigerant in the refrigerant system}}{\text{size (ft}^3\text{) of smallest room in which there is an indoor unit installed}} \leq \text{maximum concentration level (lb./ft}^3\text{)}$$

If the result of the above calculation exceeds the maximum concentration level then make similar calculations for the second then third smallest room and so until the result falls short of the maximum concentration.

4. Dealing with the situations where the result exceeds the maximum concentration level.

Where the installation of a facility results in a concentration in excess of the maximum concentration level then it will be necessary to revise the system.

Please consult your Daikin supplier.



# Part 3

# Installation Manual

# BS Unit

1. Safety Considerations .....	172
2. Before Installation .....	175
2.1 Caution Concerning New Refrigerant Series .....	175
2.2 Precautions .....	175
2.3 Accessories .....	176
2.4 Combination .....	177
3. Selecting Installation Site .....	178
4. Preparations Before Installation .....	179
5. BS Unit Installation.....	180
6. Refrigerant Piping Work.....	181
6.1 In Case of Connecting Only One Indoor Unit .....	183
6.2 When Connecting Multiple Indoor Units .....	183
6.3 Selection of Pipe Connection Size .....	183
6.4 Piping Connection .....	184
7. Electric Wiring Work.....	185
7.1 General Instructions .....	185
7.2 Example for the Whole System .....	185
7.3 Electrical Characteristics .....	185
7.4 Specifications for Field Supplied Fuses and Wire .....	186
7.5 Gist of Field Line Connection .....	186
7.6 Initial Setting.....	189
8. Test Operation .....	190

## [Applicable models]

**BSVQ36MVJ**

**BSVQ60MVJ**

# 1. Safety Considerations

Please read these “SAFETY CONSIDERATIONS” carefully before installing air conditioning equipment and be sure to install it correctly. After completing the installation, make sure that the unit operates properly during the start-up operation.

Please instruct the customer on how to operate the unit and keep it maintained.

Also, inform customers that they should store this installation manual along with the operation manual for future reference.

This air conditioner comes under the term “appliances not accessible to the general public”.

Meaning of warning, caution and note symbols.



**WARNING** ..... Indication a potentially hazardous situation which, if not avoided, could result in death or serious injury.



**CAUTION** ..... Indication a potentially hazardous situation which, if not avoided, may result in minor or moderate injury. It may also be used to alert against unsafe practices.



**Note** ..... Indication situation that may result in equipment or property-damage-only accidents.



## WARNING

- **Ask your dealer or qualified personnel to carry out installation work. Do not try to install the machine by yourself.**  
Improper installation may result in water leakage, electric shocks or fire.
- **Perform installation work in accordance with this installation manual.**  
Improper installation may result in water leakage, electric shocks or fire.
- **When installing the unit in a small room, take measures against to keep refrigerant concentration from exceeding allowable safety limits in the event of refrigerant leakage.**  
Contact the place of purchase for more information. Excessive refrigerant in a closed ambient can lead to oxygen deficiency.
- **Be sure to use only the specified accessories and parts for installation work.**  
Failure to use the specified parts may result in water leakage, electric shocks, fire or the unit falling.
- **Install the air conditioner on a foundation strong enough to withstand the weight of the unit.**  
A foundation of insufficient strength may result in the equipment falling and causing injuries.
- **Carry out the specified installation work after taking into account strong winds, typhoons or earthquakes.**  
Improper installation work may result in the equipment falling and causing accidents.
- **Make sure that a separate power supply circuit is provided for this unit and that all electrical work is carried out by qualified personnel according to local laws and regulations and this installation manual.**  
An insufficient power supply capacity or improper electrical construction may lead to electric shocks or fire.
- **Make sure that all wiring is secured, the specified wires are used, and no external forces act on the terminal connections or wires.**  
Improper connections or installation may result in fire.

- **When wiring the power supply and connecting the remote controller wiring and transmission wiring, position the wires so that the electric parts box lid can be securely fastened.**  
Improper positioning of the electric parts box lid may result in electric shocks, fire or the terminals overheating.
- **If the refrigerant gas leaks during installation, ventilate the area immediately.**  
Toxic gas may be produced if the refrigerant gas comes into contact with fire.
- **After completing the installation work, check that the refrigerant gas does not leak.**  
Toxic gas may be produced if the refrigerant gas leaks into the room and comes into contact with a source of fire, such as a fan heater, stove or cooker.
- **Before touching electrical parts, turn off the unit.**
- **Ground the air conditioner. Do not connect the ground wire to gas or water pipes, lightning rod or a telephone ground wire.**  
Incomplete grounding may result in electric shocks.
- **Do not touch the switch with wet fingers.**  
Touching a switch with wet fingers can cause electric shock.
- **Install a leak circuit breaker, as required.**  
If a leak circuit breaker is not installed, electric shock may result.
- **Do not install the air conditioner in the following locations:**
  - (a) where a mineral oil mist or an oil spray or vapor is produced, for example in a kitchen Plastic parts may deteriorate and fall off or result in water leakage.
  - (b) where corrosive gas, such as sulfurous acid gas, is produced Corroding copper pipes or soldered parts may result in refrigerant leakage.
  - (c) near machinery emitting electromagnetic waves Electromagnetic waves may disturb the operation of the control system and result in a malfunction of the equipment.
  - (d) where flammable gases may leak, where there are carbon fiber or ignitable dust suspensions in the air, or where volatile flammables such as thinner or gasoline are handled.  
Operating the unit in such conditions may result in fire.

**CAUTION**

- **While following the instructions in this installation manual, insulate piping in order to prevent condensation.**  
Improper piping insulation may result in water leakage and property damage.
- **Be very careful about product transportation.**  
Some products use PP bands for packaging. Do not use any PP bands for a means of transportation. It is dangerous.
- **Safely dispose of the packing materials.**  
Packing materials, such as nails and other metal or wooden parts, may cause stabs or other injuries. Tear apart and throw away plastic packaging bags so that children will not play with them. If children play with a plastic bag which was not torn apart, they face the risk of suffocation.

**NOTE:**

- **Install the indoor and outdoor units, power supply wiring and connecting wires at least 3.5ft. away from televisions or radios in order to prevent image interference or noise.**  
(Depending on the radio waves, a distance of 3.5ft. may not be sufficient enough to eliminate the noise.)
- **Remote controller (wireless kit) transmitting distance can result shorter than expected in rooms with electronic fluorescent lamps. (inverter or rapid start types)**  
Install the indoor unit as far away from fluorescent lamps as possible.
- **This unit is a class A product.**  
In a domestic environment this product may cause radio interference in which case the user may be required to take adequate measures.
- **Dismantling of the unit, treatment of the refrigerant, oil and eventual other parts, should be done in accordance with the relevant local and national regulations.**

**CAUTION**

The refrigerant R410A requires strict cautions for keeping the system clean, dry and tight.

A.Clean and dry

Foreign materials (including mineral oils such as SUNISO oil or moisture) should be prevented from getting mixed into the system.

B.Tight

R410A does not contain any chlorine, does not destroy the ozone layer, and does not reduce the earth's protection against harmful ultraviolet radiation.

R410A can contribute slightly to the greenhouse effect if it is released. Therefore we should take special attention to check the tightness of the installation.

Read the chapter "Refrigerant piping work" carefully and follow these procedures correctly.

## 2. Before Installation

### 2.1 Caution Concerning New Refrigerant Series

Since R410A is a mixed refrigerant, the required additional refrigerant must be charged in its liquid state. (If the refrigerant is charged in a state of gas, its composition changes and the system will not work properly.)

The indoor/outdoor unit is for R410A. See the catalog for indoor/outdoor unit models which can be connected. (Normal operation is not possible when connected to other units.)

### 2.2 Precautions

- **When moving the unit while removing it from the packing case, be sure to lift it by holding on to the four hunger brackets without exerting any pressure on other parts, especially, the refrigerant piping.**
- Be sure to check the type of R410A refrigerant to be used before installing the unit. (Using an incorrect refrigerant will prevent normal operation of the unit.)
- The accessories needed for installation must be retained in your custody until the installation work is completed. Do not discard them!
- Do not install or operate the unit in rooms mentioned below.
  - **Laden with mineral oil, or filled with oil vapor or spray like in kitchens. (Plastic parts may deteriorate which could eventually cause the unit to fall out of place, or could lead to leaks.)**
  - **Where corrosive gas like sulfurous gas exists. (Copper tubing and brazed sports may corrode, which could eventually lead to refrigerant leaks.)**
  - **Where exposed to combustible gases and where volatile flammable gas like thinner or gasoline is used. (Gas in the vicinity of the unit could ignite.)**
  - **Where machines can generate electromagnetic waves. (Control system may malfunction.)**
  - **Where the air contains high levels of salt such as that near the ocean and where voltage fluctuates greatly such as that in factories. Also in vehicles or vessels.**
- Refer to the installation manual provided with the outdoor and the indoor unit. If installed as a household appliance it could cause electromagnetic interference.







**NOTE:**

- Be sure to read this manual before installing the indoor unit.
- Entrust installation to the place of purchase or a qualified serviceman. Improper installation could lead to leaks and, in worse cases, electric shock or fire.
- Use only parts provided with the unit or parts satisfying required specifications. Unspecified parts could cause the unit to fall out of place, or could lead to leaks and, in worse cases, electric shock or fire.

## 2.3 Accessories

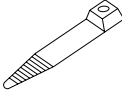
Check the following accessories are included with your unit.

<BSVQ36 · 60MVJU>

Name	1) Attached pipe			2) Clamp	3) Insulation for fitting		
	Quantity	2 pcs.	1 pc.		2 pcs.	17 pcs .	2 pcs.
Shape	1)-1 3/8"	1)-2 1/2"	1)-3 5/8"		3)-1  Thin	3)-2  Medium	3)-3  Thick
	(Attached to BSVQ36MVJU only)						

**FOR THE FOLLOWING ITEMS, TAKE SPECIAL CARE DURING CONSTRUCTION AND CHECK AFTER INSTALLATION IS FINISHED.**

### Completion check items



Check items	Problems	Check
Are the indoor, outdoor, and BS units installed securely?	Falling, vibration, and operating noise	
Have you performed a gas leak test?	Does not cool	
Is the insulation complete? (Refrigerant piping)	Water leaking	
Is the voltage the same as that listed on the unit's nameplate?	Does not operate/burnt out	
Are all the wiring and piping correct?	Does not operate/burnt out	
Is the unit grounded?	Dangers during electrical leak	
Is the thickness of the power cord as specified?	Does not operate/burnt out	
Are any obstructions blocking the indoor and outdoor units' intake and outlet vents?	Does not cool	
Have you recorded the length of the refrigerant piping and the amount of refrigerant filled?	Uncertain amount of refrigerant	

Also review the "SAFETY CONSIDERATIONS"

### Hand-over check items

Check items	Check
Did you explain to the customer how to use the unit while looking at the manual?	

#### Important points regarding operation

In addition to general operation methods, items listed with a  WARNING or  CAUTION indicate procedures that can cause physical or property damage. You must explain them to the customer as well as having him or her read these items very carefully.

## 2.4 Combination

- For series of applicable indoor units, refer to the or other literature.
- Select the BS unit to fit the total capacity sum of the indoor units to be connected downstream.  
To calculate the total capacity of the indoor units, use the figure A of the table below.

Model	Total capacity sum of all downstream indoor units
BSVQ36MVJU	$A < 36$
BSVQ60MVJU	$36 \leq A < 60$

Capacity of indoor unit

Capacity expressed as indoor unit's model No.	12	18	24	30	36	48
Indoor unit's capacity (for use in computation): A	12	18	24	30	36	48

### 3. Selecting Installation Site



**NOTE:**

- Do not throw away any of the accessories until installation is complete.
  - Hold the unit by the hunger brackets (4) when opening the box and moving it, and do not lift it holding on to any other part especially the refrigerant piping.
  - If you think the humidity inside the ceiling might exceed 86°F and RH80%, reinforce the insulation on the inter-unit piping.
  - Use glass wool or polyethylene foam as insulation so that it is no thinner than 3/8” and fits inside the ceiling opening.
- (1) Select an installation site where the following conditions are satisfied and that meets with your customer’s approval.
- Where is resistible against weight of BS unit.
  - Where sufficient clearance for maintenance and service can be ensured.
  - Where the total piping length involving indoor unit and outdoor unit is below the allowable piping length. (See installation manual attached to outdoor unit.)
  - Locations where there is no possibility of flammable gas leaking.
  - Locations where the wall is not significantly tilted.
  - Locations where an inspection hole (see figure below) can be installed.

**<BSVQ36 · 60MVJU>**

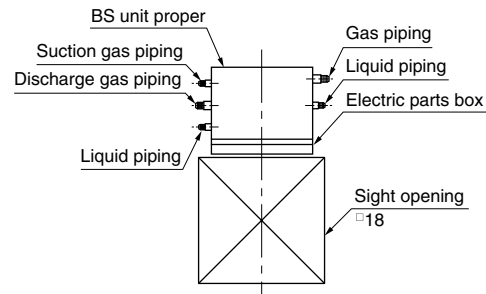
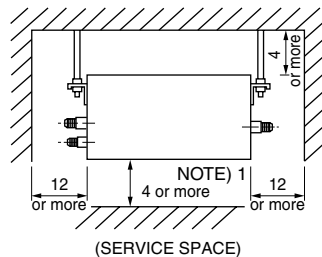

(Sight opening must be of above size and provided in front of electric parts box.)



**NOTE:**

1. Leave 4” of service space below the electric parts box. If this is not possible, open a service hole in the location indicated in the figure below.
2. Make sure the power, branch, and remote control wiring of the indoor, outdoor, and BS units are at least 40” away from radios and televisions. This is to prevent interference with picture and sound reception. (Interference may occur even at 40” away depending on the reception quality.)

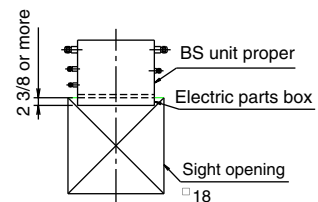

- (2) Use suspension bolts for installation. Check if the location for the installation is strong enough to support the weight of the unit, reinforce it if necessary, and install using suspension bolts.



## 4. Preparations Before Installation

### (1) Position of suspension bolts on the BS unit.

<BSVQ36 · 60MVJU>

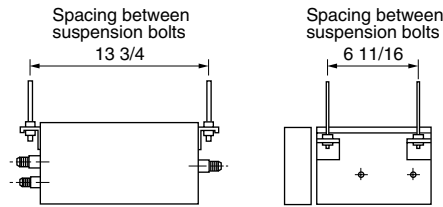

### (2) Install suspension bolts.

- Use M8-M10 suspension bolts.
- When holes are to be made anew, use inserts or anchor bolts. When holes are already provided, use hole-in anchors or the like. Install the BS unit so that its weight can be withstood.

Note: All the above parts are part to be procured in the field.

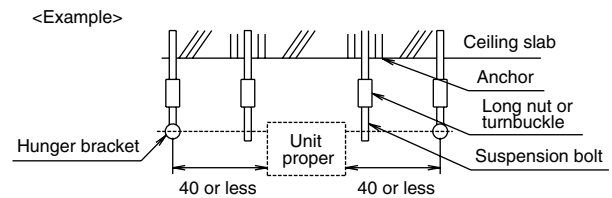

### (3) Support the connection piping.

- To prevent excessive weight from bearing on the hunger brackets of the BS unit, support the connection piping around the unit and no further away than 40" from the unit. Too much weight on the hunger brackets will cause the BS unit to drop and cause injury.

## 5. BS Unit Installation

- (1) Attach the hunger brackets to the suspension bolts.  
Be sure to sandwich the hunger brackets between nuts and washers, and securely fix it.

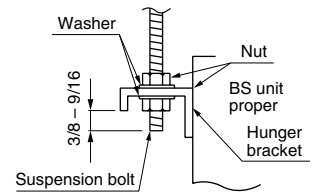

### CAUTION

- The BS unit has a top and a bottom, so install it so that the diagonal lines in the figure next page are where the top is. (Failing to do so may prevent the unit from operating properly and increase the volume of the operating noise.)

- (2) The electric parts box may be installed on either side of the BS unit, as shown below.

1. Remove the electric parts box lid. (2 screws)
2. Remove the top panel. (4 screws)
3. Remove the electric parts box. (2 screws)
4. Change the way the wiring between the unit and the electric parts box (transformer, two solenoid valve coils) is pulled out. (See the figure at next page.)
5. Attach the electric parts box.
6. Turn the top panel around 180° and attach it.
7. Attach the electric parts box lid.

### Changing the installation position of the electric parts box

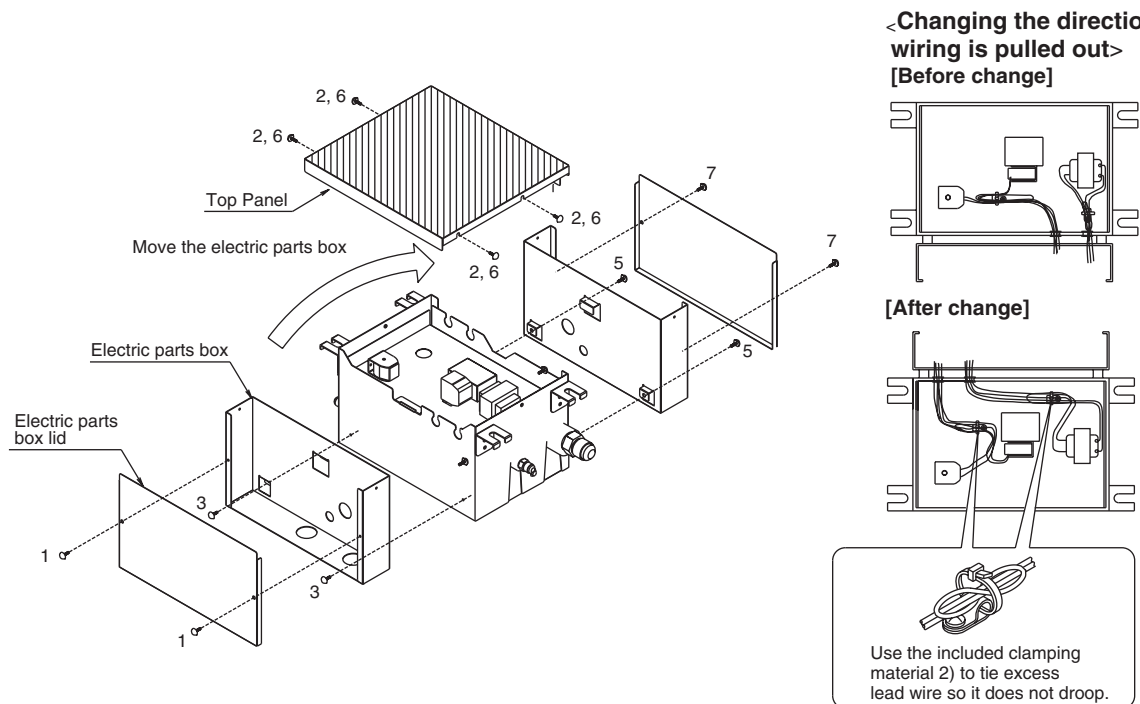

### NOTE:

- Install the BS unit according to the instructions shown on the name plate attached to the electric parts box.
- Clamp securely so the interior wiring does not touch the screws or sheet metal due to looseness.

## 6. Refrigerant Piping Work

- This section describes how to connect the piping to the BS unit. Select the piping size based on the procedure outlined here.
- Regarding piping work between the outdoor unit and the BS unit, selection of the branch kit, and the piping work between the branch kit and the indoor unit, see the installation manual for the outdoor unit and other technical documents.
- Always check that the refrigerant to be used is R410A before starting work. (If the wrong refrigerant is used, the unit will not operate normally.)
- Completely insulate the discharge and suction piping both liquid and gas. Not insulating them may cause leaking or burns. Only use insulating material which is resistant to 250°F or higher. If you think the humidity in the ceiling might exceed 86°F and RH80%, reinforce the insulation on the cooling piping (at least 13/16" thick). Condensation might form on the surface of the insulation.



### CAUTION

- Use a pipe cutter and flare suitable for R410A.
- Use a piping branch pipe kit selected based on the selection procedure for refrigerant branch kits.
- See the installation manual for the outdoor unit and other relevant technical documents for details on refrigerant branch kit selection, maximum piping length, maximum height difference, and maximum length after branch.
- Apply ether oil or ester oil around the flare portions before connecting.
- Only use the flare nuts included with the unit. Using different flare nuts may cause the refrigerant to leak.
- To prevent dust, moisture or other foreign matter from infiltrating the tube, either pinch the end or cover it with tape.
- The outdoor unit is charged with refrigerant.
- Be sure to use both a spanner and torque wrench together when connecting or disconnecting pipes to/from the unit. **(Refer to Fig. 2)**
- When connecting the flare nut, coat the flare both inside and outside with refrigerating machine oil and initially tighten by your hand 3 or 4 turns. **(Refer to Fig. 3)**
- Refer to the Table 1 for the measurements of tightening torque and flare. Overtightening may damage the flare.
- Refer to Table 2 if no torque wrench is available.  
Using a wrench to tighten flare nuts causes the tightening torque to suddenly grow much tighter after a certain point. From there, tighten the nut further by the appropriate angle listed in Table 2. After this is done, make sure no gas is leaking.
- When brazing the refrigerant piping, perform nitrogen replacement (note 1) first or perform the brazing (note 3) while feeding nitrogen into the refrigerant piping (note 2), and finally connect the indoor unit and BS unit using the flare or flange connections.

#### Notes

1. For details on nitrogen replacement, see the "VRV Installation Manual" (available at any Daikin dealer).
  2. When feeding nitrogen into the pipes while doing the brazing, the pressure-reducing valve should be set to 2.9psi. **(Refer to Fig. 5)**
  3. Do not use a flux when brazing the refrigerant pipe joints.  
Use phosphor copper brazing (B cup) which does not require flux.  
(Using a chlorine flux may cause the pipes to corrode, and if it contains fluoride it may cause the refrigerant lubricant to deteriorate, adversely affecting the refrigerant piping system.)
- Piping connections should be checked for gas leaks and then, referring to Fig. 4, insulated using the included joint insulating material 3) on all liquid and gas pipes (a total of 5 locations) (Tighten both edges with clamp 2.) Use the included joint insulating material.

- For locally procured insulation, be sure to insulate all the way to the pipe connections inside the machine.  
Exposed piping may cause condensation to form or burns on contact.
- Use the following material specification for refrigerant piping:
  - (1) construction material: Phosphoric acid deoxidized seamless copper for refrigerant.
  - (2) size: Determine the proper size referring to chapter “SELECTION OF PIPE CONNECTION SIZE”
  - (3) The wall thickness of the refrigerant piping should comply with relevant local and national regulations.
- Ventilate if refrigerant gas leaks while performing work.
- Finally make sure there is no refrigerant gas leak. A toxic gas may be released by the refrigerant gas leaking indoor and being exposed to flames from an area heater, cooking stove, etc.

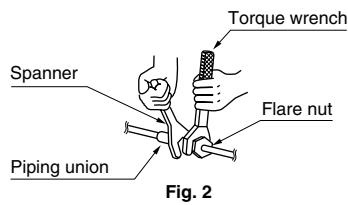

Fig. 2

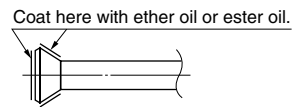

Fig. 3

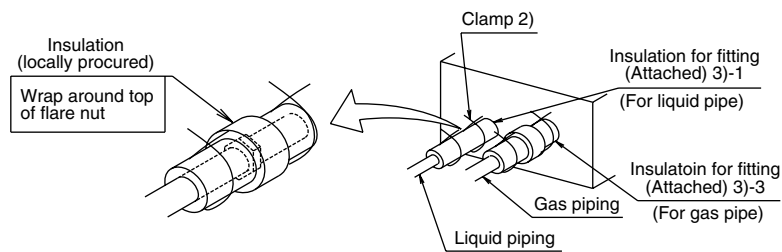

Fig. 4

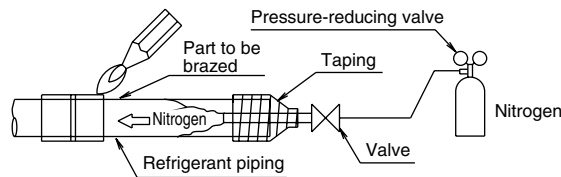

Fig. 5

Table 1

Pipe gauge (in)	Tightening torque (ft-lbf)	Flare dimension A (in)	Flare shape (in)
1/4"	10.5 – 12.7	0.343 – 0.358	
3/8"	24.1 – 29.4	0.504 – 0.520	
1/2"	36.5 – 44.5	0.638 – 0.654	
5/8"	45.6 – 55.6	0.760 – 0.776	

Table 2

Pipe size (in)	Further tightening angle (degree)	Recommended arm length of tool (in)
1/4"	60 to 90	Approx. 5 7/8"
3/8"	60 to 90	Approx. 7 7/8"
1/2"	30 to 60	Approx. 9 13/16"
5/8"	30 to 60	Approx. 11 13/16"

## 6.1 In Case of Connecting Only One Indoor Unit

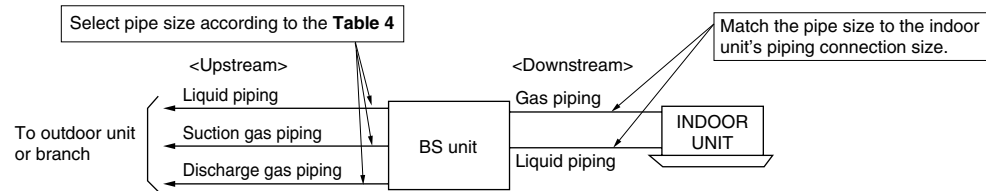

## 6.2 When Connecting Multiple Indoor Units

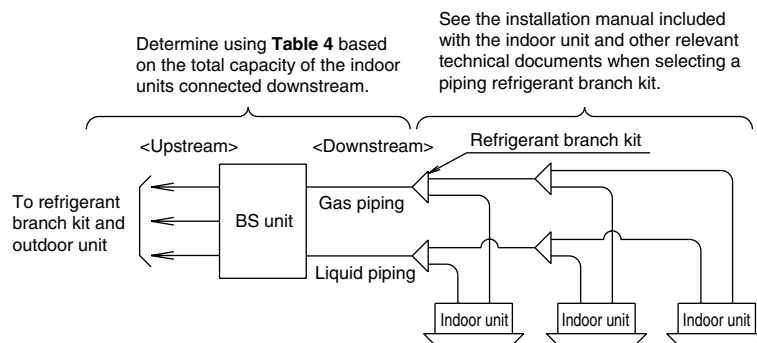

## 6.3 Selection of Pipe Connection Size

**Table 3 <Indoor and BS Unit Connection Piping Sizes>**

Target unit		Piping size (outer diameter) (in)	
		Gas pipe	Liquid pipe
Indoor unit's model No.	12, 18	1/2	1/4
	24, 30, 36, 48	5/8	3/8
BS unit	BSVQ36MVJU	5/8	3/8
	BSVQ60MVJU		

Note: The piping size for the BS unit indicates the size of the connection side with the indoor unit.

**Table 4 < Selection of Piping Size Based on Total Capacity of Indoor Unit >**

Total capacity of indoor units [ $\times 10^3$ Btu/h]	Piping size (outer diameter) (in)				
	Upstream			Downstream	
	Suction gas pipe	Discharge gas pipe	Liquid pipe	Gas pipe	Liquid pipe
Up to 24	1/2	3/8	1/4	1/2	1/4
24 or more and less than 60	5/8	1/2	3/8	5/8	3/8

See the section on “2-4 COMBINATION” at page 4 for details on indoor unit capacity.

## 6.4 Piping Connection

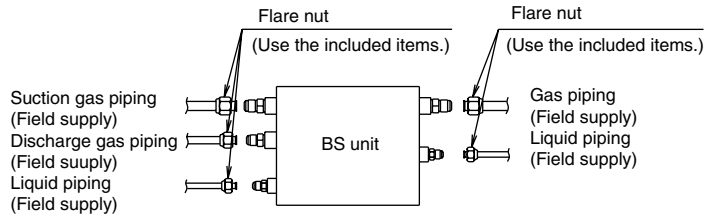

If the total capacity of the Q36-type indoor units downstream is less than 24

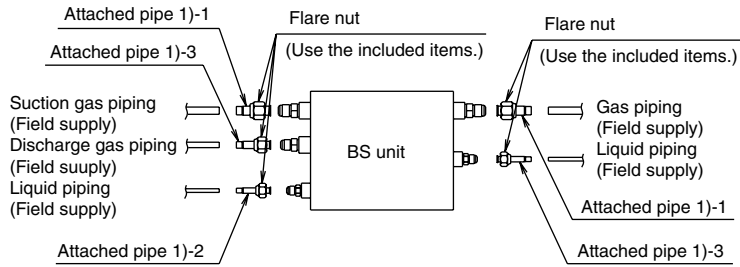

## 7. Electric Wiring Work

### 7.1 General Instructions

- All field supplied parts and materials, electric works must conform to local codes.
- Use copper wire only.
- Follow the “WIRING DIAGRAM” attached to the unit body to wire the outdoor unit and indoor units.
- All wiring must be performed by an authorized electrician.
- This system consists of multiple BS units. Mark each BS unit as unit A, unit B . . . , and be sure the terminal board wiring to the outdoor unit and indoor unit are properly matched. If wiring and piping between the outdoor unit, BS unit and an indoor unit are mismatched, the system may cause a malfunction.
- A circuit breaker capable of shutting down the power supply to the entire system must be installed.
- Always ground wires. (In accordance with national regulations of the pertinent country.)
- Do not let the ground wire come in contact with gas pipes, water pipes, lightning rods, or telephone ground wires.
  - Gas pipes: gas leaks can cause explosions and fire.
  - Water pipes: cannot be grounded if hard vinyl pipes are used.
  - Telephone ground wires and lightning rods: the ground potential when struck by lightning gets extremely high.
- Do not turn on the power supply (branch switches, overload interrupters) until all other work is done.

### 7.2 Example for the Whole System

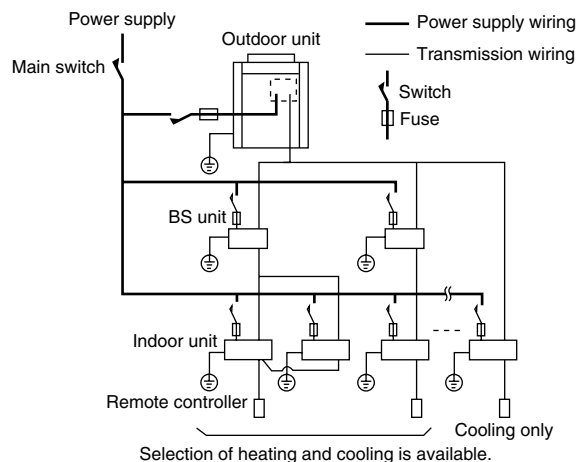

### 7.3 Electrical Characteristics

Model	Type	Units				Power supply	
		Hz	Voltage	Min.	Max.	MCA	MFA
BSVQ36M BSVQ60M	VJ	60	230	187	253	0.2	15

MCA: Min. Circuit Amps (A); MFA: Max. Fuse Amps (A)



**NOTE:**

- The above Table of Electrical Characteristics refers to the BS unit only.
- See the technical documents for other details.

## 7.4 Specifications for Field Supplied Fuses and Wire

Model	Power supply wiring		Transmission wiring	
	Field fuse	Size	Wire	Size
BSVQ36M	15A	Size must comply with local codes.	Sheathed wire (2 wire) (NOTE 2)	AWG18-16
BSVQ60M				



**NOTE:**

1. Select the particular size of electric wire for power line in accordance with the standards of the given nation and region.
2. Insulated thickness: 1/16" or more
3. Allowable length of the transmission wiring should be as follows.  
Between outdoor unit, BS unit and indoor unit: Max. 3280ft (Total wiring length: 6560ft)  
Between BS unit and remote controller: Max. 1640ft  
Max. branches No. of branches: 16
4. Up to 16 branches are possible for unit-to-unit cabling. No branching is allowed after branching.

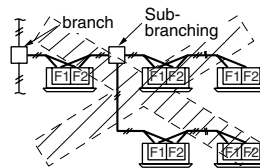

## 7.5 Gist of Field Line Connection

- Remove the side cover of the electric parts box shown in the below figure and connect each wire.

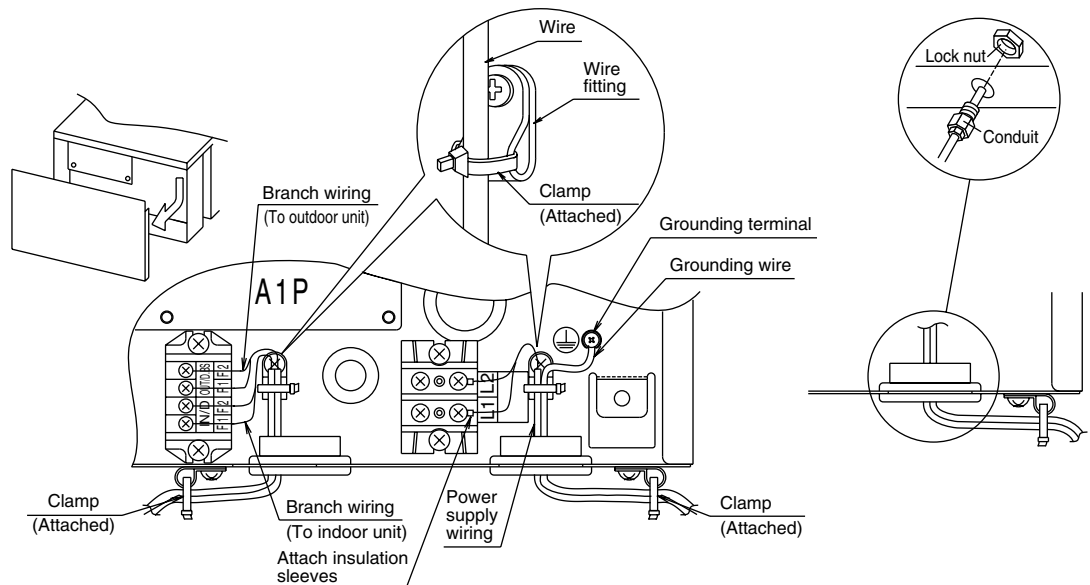

**NOTE:**

- Keep transmission wiring a minimum of 2" from other electric wires so as to avoid the effects of external noise. (Bundle transmission wiring separate of other wires, with the included tie-wrap.)
- Do not connect power wiring to the transmission wiring terminal.
- Doing so could damage the entire system.



- Clamp power wiring and the grounding wire together with the included clamp.
- When clamping wiring, use the included clamping material 2) to prevent outside pressure being exerted on the wiring connections and clamp firmly.
- When doing the wiring, make sure the wiring is neat and does not cause the electric parts box lid to stick up, then close the cover firmly. When attaching the electric parts box lid, make sure you do not pinch any wires. To prevent the wires from damaging, be sure to pass all wires through the wiring guide.
- After wiring work is complete, block all gaps in the holes for passing out wiring using sealing material (locally procured).  
(This is to prevent insects from entering the machine.)

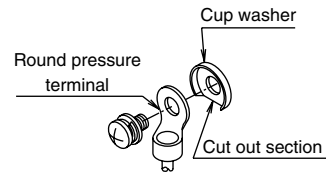

### PRECAUTIONS

1. Use ring-type crimp-style terminals for connecting wires to the power supply terminal board. If unavailable, observe the following points when wiring.

- Do not connect wires of different gauge to the same power supply terminal. (Looseness in the connection may cause overheating.)
- When connecting wires of the same gauge, connect them according to the righthand figure.
- Use the specified electric wire. Connect the wire securely to the terminal. Lock the wire down without applying excessive force to the terminal.
- Use an appropriate screwdriver for tightening the terminal screws. A screwdriver with a small head will strip the head and make proper tightening impossible.
- Over-tightening the terminal screws may break them.
- See the following table for the tightening torque of the terminal screws.

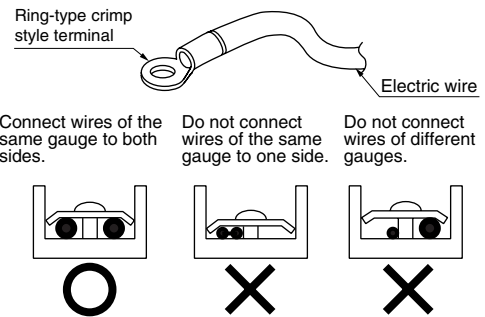

	Tightening torque (ft-lbf)
Remote controller/branch wiring terminal block (4P)	0.58~0.72
Power supply terminal block (2P)	0.87~1.06
Grounding wire	1.12~37

2. Do not connect wires of different gauge to the same grounding terminal. Looseness in the connection may deteriorate protection.
3. Keep transmission wiring at least 2" away from power supply wiring. The equipment may malfunction if subjected to electrical (external) noise.
4. For remote controller wiring, refer to the "INSTALLATION MANUAL OF REMOTE CONTROLLER" attached to the remote controller.
5. Never connect power supply wiring to the terminal board for transmission wiring. A mistake of the sort could damage the entire system.
6. Use only specified wire and tightly connect wires to terminals. Be careful wires do not place external stress on terminals. Keep wiring in neat order and so as not to obstruct other equipment such as popping open the service cover. Make sure the cover closes tight. Incomplete connections could result in overheating, and in worse case, electric shock or fire.
7. Use 2-core wires for branch wiring.  
When wiring more than 2 indoor units and a remote controller with the same 3-core wire (or other multi core wire), units sometimes stop unexpectedly because of trouble.  
(3-core wires can be used only for the cool/heat selector)
8. Connect the cooling unit to pins F1 and F2 (outdoor unit) in the final BS unit.

**EXAMPLE OF TRANSMISSION LINE CONNECTION**

- Example of connecting transmission wiring.  
Connect the transmission wirings as shown in the Fig. 1.

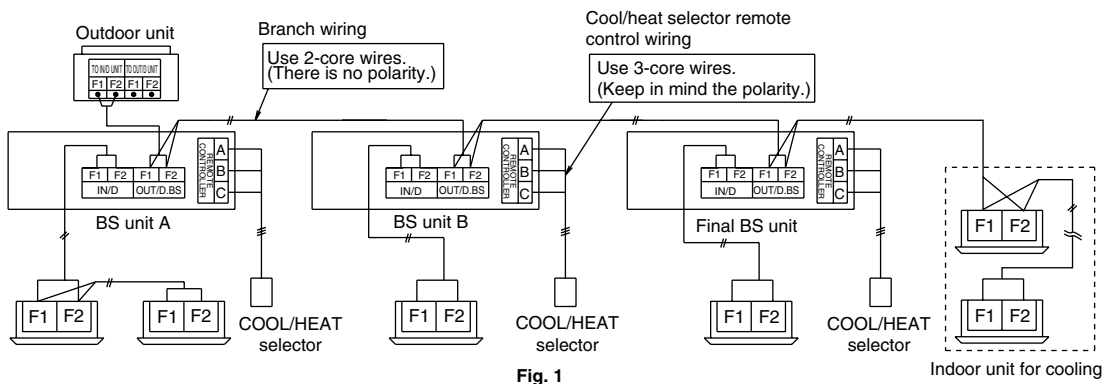
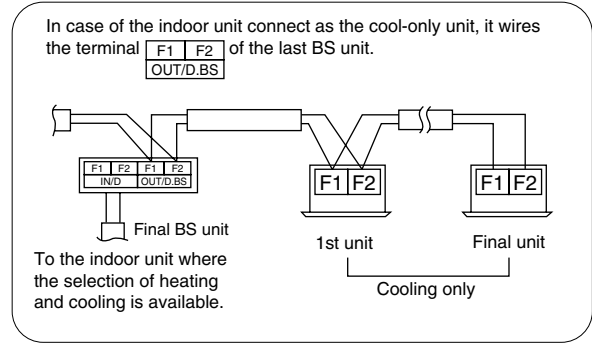

## 7.6 Initial Setting

After finishing wiring work, set the followings if necessary.

### 1. COOL/HEAT temperature difference setting switch (Set indoor unit remote controller to field setting mode.)

- Used to change the temperature difference upon occurrence of which to start cooling and heating in the automatic COOL/HEAT mode.

Settings are made from the remote controller of the indoor unit connected to the BS unit. The unit must be in “**Field setting mode**”. Make settings as explained in “**Field setting**” (provided with the remote controller).

Mode No.	First code No.	Second code No.	COOL/HEAT temperature difference (°F)
12 (22)	4	1	0
		2	1.8
		3	3.6
		4	5.4
		5	7.2
		6	9.0
		7	10.8
		8	12.6

The first and second code Nos. are set to 1 and 0°F respectively when the unit is shipped for the factory.

### 2. Remote controller change over switch (SS1, SS2)

- When using COOL/HEAT selector, turn this switch to the BS side.



NOTE: This setting must be completed before turning power supply ON.

When using cool/heat selector, connect to the terminal A, B and C on the EC of the electric parts box.

## 8. Test Operation

Refer to the installation manual of the outdoor unit.

- The operation lamp of the remote controller connected to the indoor unit will flash when an error occurs.

Check the error code on the liquid crystal display to identify the point of trouble. An explanation of error codes and the corresponding trouble is provided in "CAUTION FOR SERVICING" of the indoor unit.

# Part 4

# Operation Manual

1. Safety Considerations .....	193
2. What to Do Before Operation.....	197
3. Remote Controller and Changeover Switch: Name and Function of Each Switch and Display.....	198
4. Operation Range.....	200
5. Operation Procedure.....	201
5.1 Cooling, Heating, Automatic, and Fan Only Operation .....	201
5.2 Program Dry Operation.....	203
5.3 Adjusting the Air Flow Direction .....	205
5.4 Programming Start and Stop of the System with Timer.....	206
5.5 Setting the Master Remote Controller.....	207
5.6 Precautions for Group Control System or Two Remote Controller Control System.....	208
6. Optimum Operation.....	209
7. Following Symptoms are not Air Conditioner Troubles .....	210
7.1 The System does not Operate .....	210
7.2 Cool/heat cannot be Changed Over .....	210
7.3 Fan Operation is Possible, but Cooling and Heating do not Work.....	210
7.4 The Fan Strength does not Correspond to the Setting .....	210
7.5 The Fan Direction does not Correspond to the Setting.....	210
7.6 White Mist comes out of a Unit .....	211
7.7 Noise of Air Conditioners .....	211
7.8 Dust comes out of the Unit.....	212
7.9 The Units can Give off Odours.....	212
7.10 The Outdoor Unit Fan does not Spin .....	212
7.11 The Display Shows “88” .....	212
7.12 The Compressor in the Outdoor Unit does not Stop after a Short Heating Operation .....	212
7.13 The Inside of an Outdoor Unit is Warm even when the Unit has Stopped.....	212
8. Troubleshooting .....	213

Thank you for purchasing this Daikin air conditioner. Carefully read this operation manual before using the air conditioner. It will tell you how to use the unit properly and help you if any trouble occurs. After reading the manual, file it away for future reference.

**[Applicable model]**

**RXYQ96MTJU**

**REYQ96MTJU**

# 1. Safety Considerations

Please read these “SAFETY CONSIDERATIONS” carefully before installing air conditioning equipment and be sure to install it correctly. After completing the installation, make sure that the unit operates properly during the start-up operation.

Please instruct the customer on how to operate the unit and keep it maintained.

Also, inform customers that they should store this operation manual along with the installation manual for future reference.

This air conditioner comes under the term “appliances not accessible to the general public”.

Meaning of warning, caution and note symbols.



**WARNING** ..... Indication a potentially hazardous situation which, if not avoided, could result in death or serious injury.



**CAUTION** ..... Indication a potentially hazardous situation which, if not avoided, may result in minor or moderate injury. It may also be used to alert against unsafe practices.



**Note** ..... Indication situation that may result in equipment or property-damage-only accidents.

**Keep these warning sheets handy so that you can refer to them if needed.**

Also, if this equipment is transferred to a new user, make sure to hand over this operation manual to the new user.



## WARNING

- **It is not good for your health to expose your body to the air flow for a long time.**
- **In order to avoid electric shock, fire or injury, or if you detect any abnormality such as smell of fire, turn off power and call your dealer for instructions.**
- **Ask your dealer for installation of the air conditioner.**  
Incomplete installation performed by yourself may result in a water leakage, electric shock, and fire.
- **Ask your dealer for improvement, repair, and maintenance.**  
Incomplete improvement, repair, and maintenance may result in a water leakage, electric shock, and fire.
- **The refrigerant in the air conditioner is safe and normally does not leak. If the refrigerant leaks inside the room, the contact with a fire of a burner, a heater or a cooker may result in a harmful gas.**  
Do not use the air conditioner until when a service person confirms to finish repairing the portion where the refrigerant leaks.
- **For refrigerant leakage, consult your dealer.**  
When the air conditioner is to be installed in a small room, it is necessary to take proper measures so that the amount of any leaked refrigerant does not exceed the limiting concentration even when it leaks. If the refrigerant leaks exceeding the level of limiting concentration, an oxygen deficiency accident may happen.

- **Improper installation or attachment of equipment or accessories could result in electric shock, short-circuit, leaks, fire or other damage to the equipment. Be sure only to use accessories made by Daikin which are specifically designed for use with the equipment and have them installed by a professional.**
- **Ask your dealer to move and reinstall the air conditioner.**  
Incomplete installation may result in a water leakage, electric shock, and fire.
- **Never let the indoor unit or the remote controller get wet.**  
It may cause an electric shock or a fire.
- **Never use flammable spray such as hair spray, lacquer or paint near the unit.**  
It may cause a fire.
- **Never replace a fuse with that of wrong ampere ratings or other wires when a fuse blows out.**  
Use of wire or copper wire may cause the unit to break down or cause a fire.
- **Never remove the fan guard of the unit.**  
A fan rotating at high speed without the fan guard is very dangerous.
- **Never inspect or service the unit by yourself.**  
Ask a qualified service person to perform this work.
- **Cut off all electric waves before maintenance.**
- **To avoid the risk of serious electric shock, never sprinkle or spill water or liquids on the unit.**
- **Do not install the air conditioner at any place where flammable gas may leak out.**  
If the gas leaks out and stays around the air conditioner, a fire may break out.
- **Do not touch the switch with wet fingers.**  
Touching a switch with wet fingers can cause electric shock.
- **Do not use the air conditioner for other purposes.**  
In order to avoid any quality deterioration, do not use the unit for cooling precision instruments, food, plants, animals or works of art.
- **Do not place items under the indoor unit which may be damaged by water.**  
Condensation may form if the humidity is above 80% or if the drain outlet gets blocked.
- **To avoid oxygen deficiency, ventilate the room sufficiently if equipment with burner is used together with the air conditioner.**
- **After a long use, check the unit stand and fitting for damage.**  
If they are left in a damaged condition, the unit may fall and result in injury.
- **Before cleaning, be sure to stop the operation, turn the breaker off or pull out the supply cord.**  
Otherwise, an electric shock and injury may result.

**CAUTION**









- **Do not operate the air conditioner with a wet hand.**  
An electric shock may result.
- **Do not allow a child to mount on the unit or avoid placing any object on it.**  
Falling or tumbling may result in injury.
- **Never expose little children, plants or animals directly to the air flow.**  
Adverse influence to little children, animals and plants may result.
- **Do not wash the air conditioner with excessive water.**  
An electric shock or fire may result.
- **Do not let children play on and around the unit.**  
If they touch the unit carelessly, it may result in injury.
- **In order to avoid electric shock or fire, make sure that an earth leakage breaker is installed.**
- **Do not place a flower vase and anything containing water.**  
Water may enter the unit, causing an electric shock or fire.
- **Never touch the internal parts of the controller.**  
Do not remove the front panel. Some parts inside are dangerous to touch, and a machine trouble may happen. For checking and adjusting the internal parts, contact your dealer.
- **Avoid placing the controller in a spot splashed with water.**  
Water coming inside the machine may cause an electric leak or may damage the internal electronic parts.
- **Do not operate the air conditioner when using a room fumigation - type insecticide.**  
Failure to observe could cause the chemicals to become deposited in the unit, which could endanger the health of those who are hypersensitive to chemicals.
- **Do not put a finger, a rod or other objects into the air inlet or outlet. As the fan is rotating at high speed, it will cause injury.**
- **Do not touch the heat exchanger fins.**  
Improper handling may result in injury.
- **Safely dispose of the packing materials.**  
Packing materials, such as nails and other metal or wooden parts, may cause stabs or other injuries.  
Tear apart and throw away plastic packaging bags so that children will not play with them. If children play with a plastic bag which was not torn apart, they face the risk of suffocation.
- **Do not turn off the power immediately after stopping operation.**  
Always wait at least five minutes before turning off the power. Otherwise, water leakage and trouble may occur.
- **The appliance is not intended for use by young children or infirm persons without supervision.**
- **The remote controller should be installed in such away that children cannot play with it.**

- **Never touch the air outlet or the horizontal blades while the swing flap is in operation.**  
Fingers may become caught or the unit may break down.
- **Never press the button of the remote controller with a hard, pointed object.**  
The remote controller may be damaged.
- **Never pull or twist the electric wire of the remote controller.**  
It may cause the unit to malfunction.
- **Do not place appliances which produce open fire in places exposed to the air flow from the unit or under the indoor unit. It may cause incomplete combustion or deformation of the unit due to the heat.**
- **Arrange the drain hose to ensure smooth drainage. Incomplete drainage may cause wetting of the building, furniture etc.**
- **Do not place the controller exposed to direct sunlight.**  
The LCD display may get discolored, failing to display the data.
- **Do not wipe the controller operation panel with benzine, thinner, chemical dustcloth, etc.**  
The panel may get discolored or the coating peeled off. If it is heavily dirty, soak a cloth in water-diluted neutral detergent, squeeze it well and wipe the panel clean. And wipe it with another dry cloth.
- **Dismantling of the unit, treatment of the refrigerant, oil and eventual other parts, should be done in accordance with the relevant local and national regulations.**

## 2. What to Do Before Operation

This operation manual is for the following systems with standard control. Before initiating operation, contact your Daikin dealer for the operation that corresponds to your system type and mark. If your installation has a customized control system, ask your Daikin dealer for the operation that corresponds to your system.

Outdoor units

	Cool/heat changeover remote control switch	Operation modes
<b>Inverter series</b>		
heat pumps <b>RXYQ</b> series	<input type="checkbox"/> yes <input type="checkbox"/> no	  
<b>Heat recovery series</b>		
heat pumps <b>REYQ</b> series	<input type="checkbox"/> yes <input type="checkbox"/> no	   

### ■ Names and functions of parts

#### RXYQ series

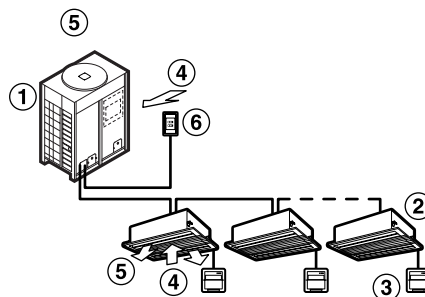

1. Outdoor unit
2. Indoor unit
3. Remote controller
4. Inlet air
5. Outlet air
6. Cool/heat changeover remote control switch
7. BS (branch selector) unit

(Left figure shows systems with changeover remote control switches)

#### REYQ series

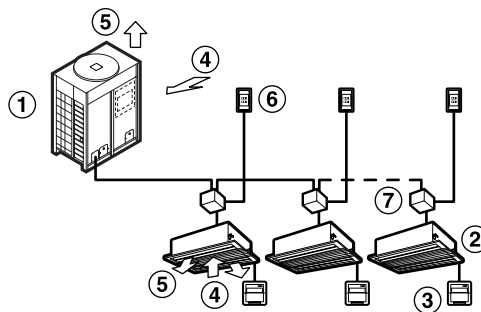

### 3. Remote Controller and Changeover Switch: Name and Function of Each Switch and Display

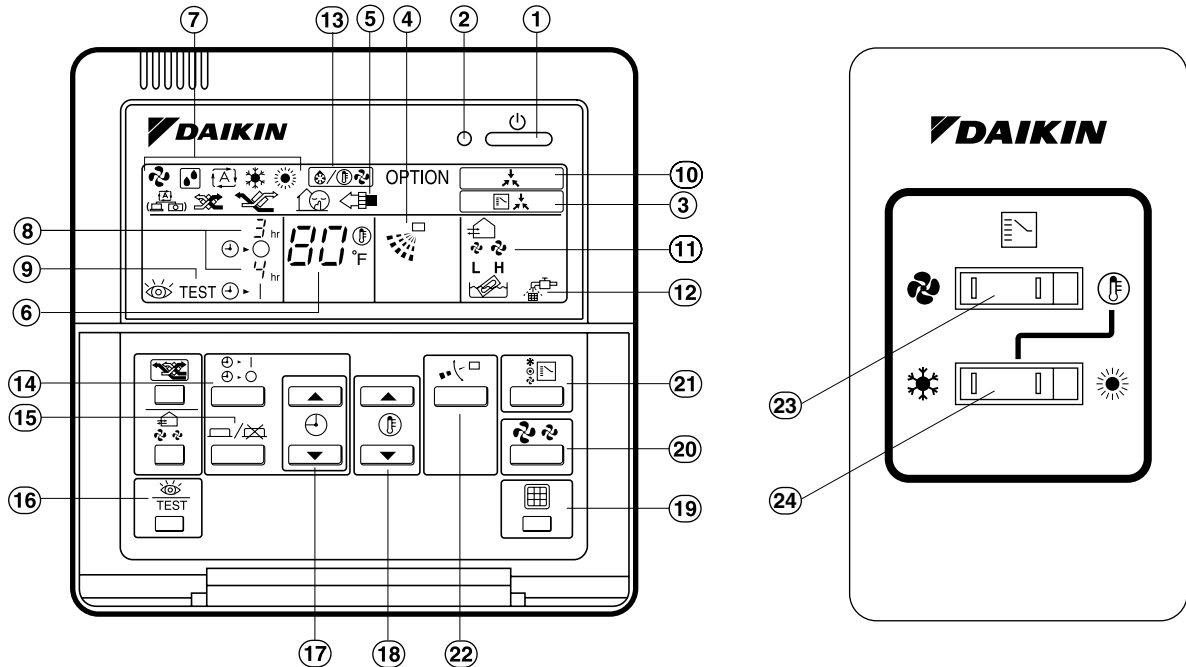

#### 1. On/off button

Press the button and the system will start. Press the button again and the system will stop.

#### 2. Operation lamp (red)

The lamp lights up during operation.

#### 3. Display “” (changeover under control)

It is impossible to changeover heat/cool with the remote controller when this icon is displayed.

#### 4. Display “” (air flow flap)

Refer to the chapter “Operation procedure - Adjusting the air flow direction”.

#### 5. Display “ OPTION” (ventilation/air cleaning)

This display shows that the total heat exchange and the air cleaning unit are in operation. (these are optional accessories)

#### 6. Display “ °F” (set temperature)

This display shows the temperature you have set.

#### 7. Display “” (operation mode)

This display shows the current operation mode.

#### 8. Display “ hr” (programmed time)

This display shows the programmed time of the system start or stop.

#### 9. Display “ TEST” (inspection/test operation)

When the inspection/test operation button is pressed, the display shows the mode in which the system actually is.

#### 10. Display “” (under centralized control)

When this display shows, the system is under centralized control. (This is not a standard specification.)

#### 11. Display “” (fan speed)

This display shows the fan speed you have selected.

#### 12. Display “” (time to clean air filter)

Refer to the indoor unit manual.

**13. Display “” (defrost/hot start)**

Refer to the chapter “Operation procedure - Explanation of heating operation.”

**14. Timer mode start/stop button**

Refer to the chapter “Operation procedure - Programming start and stop of the system with timer.”

**15. Timer on/off button**

Refer to the chapter “Operation procedure - Programming start and stop of the system with timer.”

**16. Inspection/test operation button**

This button is only used by qualified service persons for maintenance purposes.

**17. Programming time button**

Use this button for programming start and/or stop time.

**18. Temperature setting button**

Use this button for setting the desired temperature.

**19. Filter sign reset button**

Refer to the indoor unit manual.

**20. Fan speed control button**

Press this button to select the fan speed of your preference.



**21. Operation mode selector button**

Press this button to select the operation mode of your preference.



**22. Air flow direction adjust button**

Refer to the chapter “Operation procedure - Adjusting the air flow direction”.

**23. Fan only/air conditioning selector switch**

Set the switch to “” for fan only operation or to “” for heating or cooling operation.

**24. Cool/heat changeover switch**

Set the switch to “” for cooling or to “” for heating operation.

**Note:**

- In contradistinction to actual operating situations, the display on figure 2 shows all possible indications.
- If the filter sign lamp lights up, clean the air filter as explained in the indoor unit manual. After cleaning and reinstalling the air filter, press the filter sign reset button on the remote controller. The filter sign lamp on the display will go out.

## 4. Operation Range

Use the system in the following temperature and humidity ranges for safe and effective operation.

	COOLING	HEATING
outdoor temperature	23°~110°FDB	5°~60°FDB
indoor temperature	57°~77°FDB	59°~80°FDB
indoor humidity	≤ 80%*	



\*To avoid condensation and water dripping out the unit.

If the temperature or the humidity is beyond these conditions, safety devices may work and the air conditioner may not operate.

## 5. Operation Procedure



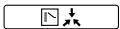

- Operation procedure varies according to the combination of outdoor unit and remote controller. Read the chapter “What to do before operation”.
- To protect the unit, turn on the main power switch 6 hours before operation.
- If the main power supply is turned off during operation, operation will restart automatically after the power turns back on again.

### 5.1 Cooling, Heating, Automatic, and Fan Only Operation

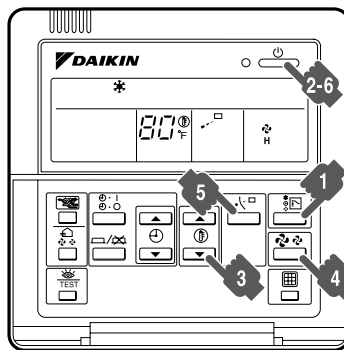
- Changeover cannot be made with a remote controller whose display shows “” (changeover under control).
- When the display “” (changeover under control) flashes, refer to the chapter “Operation procedure - Setting the master remote controller”.
- Automatic operation can be selected only by REYQ series.
- The fan may keep on running for about 1 minute after the heating operation stops.
- The air flow rate may adjust itself depending on the room temperature or the fan may stop immediately. This is not a malfunction.

#### For system without cool/heat changeover remote control switch



- 1 Press the operation mode selector button several times and select the operation mode of your choice;
  - “” Cooling operation
  - “” Heating operation
  - “” Automatic operation
  - “” Fan only operation



**Note:**

- Automatic operation (REYQ only)  
In this operation mode, cool/heat changeover is automatically conducted.
- 2 Press the on/off button.  
The operation lamp lights up and the system starts operation.

**For systems with cool/heat changeover remote control switch**

- ➊ Select operation mode with the cool/heat changeover remote control switch as follows:  
 “☀” “Ⓜ” Cooling operation

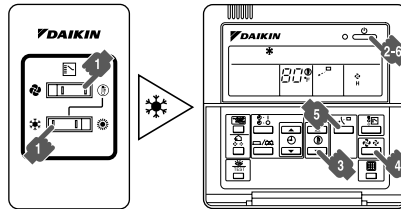

- “☀” “Ⓜ” Heating operation

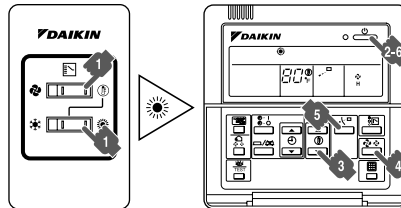

- “🌀” Fan only operation

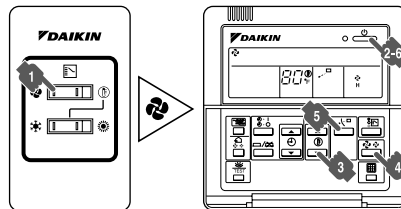

- ➋ Press the on/off button.  
The operation lamp lights up and the system starts operation.

**Adjustment**

For programming temperature, fan speed and air flow direction follow the procedure shown below.

- ➌ Press the temperature setting button and program the desired temperature.

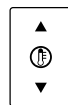

Each time this button is pressed, the temperature setting rises or lowers 1°F.



**Note:**

- Set the temperature within the operation range.
- The temperature setting is impossible for fan only operation.

- ➍ Press the fan speed control button and select the fan speed of your preference.
- ➎ Press air flow direction adjust button.  
Refer to the chapter “Adjusting the air flow direction” for details.

**Stopping the system**

- ➏ Press the on/off button once again.  
The operation lamp goes off and the system stops operation.



**Note:**

- Do not turn off power immediately after the unit stops, but wait for at least 5 minutes.



## Explanation of heating operation

### Defrost operation

- In heating operation, freezing of the outdoor unit coil increases. Heating capability decreases and the system goes into defrost operation.
- The indoor unit fan stops and the remote controller displays “”.
- After maximum 10 minutes of defrost operation, the system returns to heating operation again.

### Hot start

- In order to prevent cold air from blowing out of an indoor unit at the start of heating operation, the indoor fan is automatically stopped. The display of the remote controller shows “”.

## 5.2 Program Dry Operation

- The function of this program is to decrease the humidity in your room with a minimum temperature decrease.
- The micro computer automatically determines temperature and fan speed.
- The system does not go into operation if the room temperature is low.

For systems without cool/heat changeover remote control switch

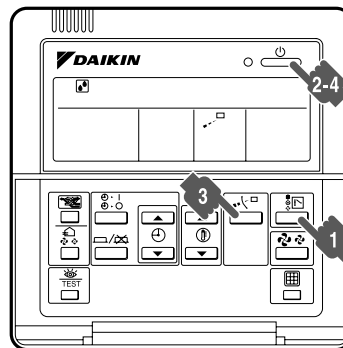

- 1 Press the operation mode selector button several times and select “” (program dry operation).
- 2 Press the on/off button  
The operation lamp lights up and the system starts operation.
- 3 Press the air flow direction adjust button. Refer to the chapter “Adjusting the air flow direction” for details.

### Stopping the system

- 4 Press the on/off button once again.  
The operation lamp goes off and the system stops operation.



**Note:** ■ Do not turn off power immediately after the unit stops, but wait for at least 5 minutes.

### For systems with cool/heat changeover remote control switch

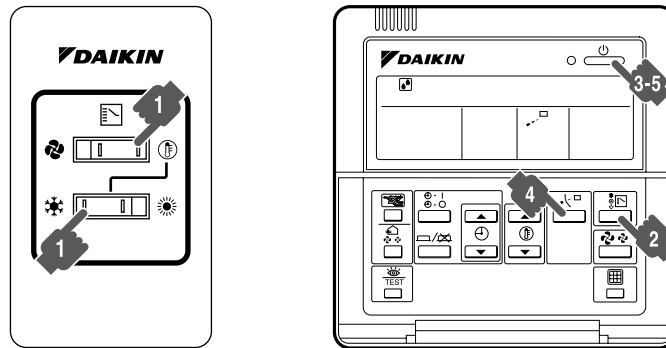

- 1 Select cooling operation mode with the cool/heat changeover remote control switch.
- 2 Press the operation mode selector button several times and select “” (program dry operation).
- 3 Press the on/off button  
The operation lamp lights up and the system starts operation.
- 4 Press the air flow direction adjust button. Refer to the chapter “Adjusting the air flow direction” for details.

#### Stopping the system

- 5 Press the on/off button once again.  
The operation lamp goes off and the system stops operation.



**Note:** ■ Do not turn off power immediately after the unit stops, but wait for at least 5 minutes.

## 5.3 Adjusting the Air Flow Direction

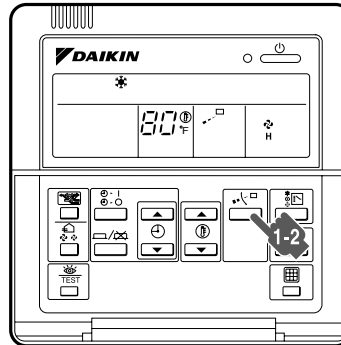

- 1 Press the air flow direction button to select the air direction.  
The air flow flap display swings as shown below and the air flow direction continuously varies. (Automatic swing setting)



- 2 Press the air flow direction adjust button to select the air direction of your choice.

The air flow flap display stops swinging and the air flow direction is fixed. (Fixed air flow direction setting)



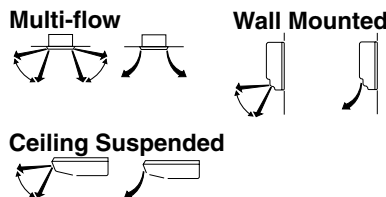

### Movement of the air flow flap



For the following conditions, a micro computer controls the air flow direction which may be different from the display.

COOLING	HEATING
_____	<ul style="list-style-type: none"> <li>■ When starting operation.</li> <li>■ When the room temperature is higher than the set temperature.</li> <li>■ At defrost operation.</li> </ul>
<ul style="list-style-type: none"> <li>■ When operating continuously at horizontal air flow direction.</li> <li>■ When continuous operation with downward air flow is performed at the time of cooling with a ceiling-suspended or a wall-mounted unit, the microcomputer may control the flow direction, and then the remote controller indication also will change.</li> </ul>	

The air flow direction can be adjusted in one of the following ways.

- The air flow flap itself adjusts its position.
- The air flow direction can be fixed by the user.
- Automatic “” and desired position “”.



#### Note:

- The movable limit of the flap is changeable. Contact your Daikin dealer for details.
- Avoid operating in the horizontal direction “”. It may cause dew or dust to settle on the ceiling.

## 5.4 Programming Start and Stop of the System with Timer

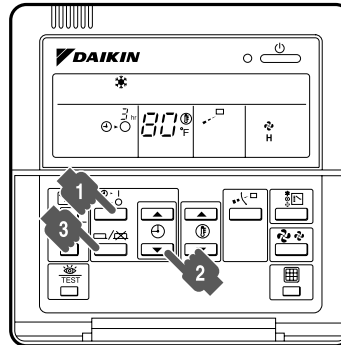

- The timer is operated in the following two ways.  
 Programming the stop time “⏸ ▶ ○”. The system stops operating after the set time has elapsed.  
 Programming the start time “⏸ ▶ |”. The system starts operating after the set time has elapsed.
- The timer can be programmed for a maximum of 72 hours.
- The start and the stop time can be simultaneously programmed.

- 1 Press the timer mode start/stop button several times and select the mode on the display.  
 The display flashes.  
 For setting the timer stop “⏸ ▶ ○”  
 For setting the timer start “⏸ ▶ |”
- 2 Press the programming time button and set the time for stopping or starting the system.

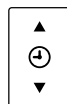

Each time this button is pressed, the time advances or goes backward by 1 hour.

- 3 Press the timer on/off button.  
 The timer setting procedure ends. The display “⏸ ▶ ○” or “⏸ ▶ |” changes from flashing light to constant light.



- Note:**
- When setting the timer off and on at the same time, repeat the above procedure (from “1” to “3”) once again.
  - After the timer is programmed, the display shows the remaining time.
  - Press the timer on/off button once again to cancel programming. The display vanishes.

**For example:**

When the timer is programmed to stop the system after 3 hours and start the system after 4 hours, the system will stop after 3 hours and start 1 hour later.

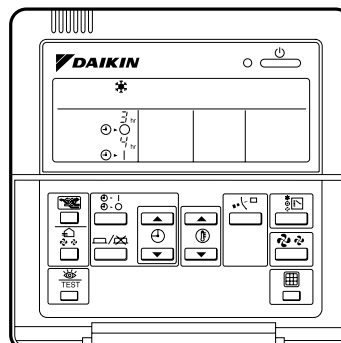

## 5.5 Setting the Master Remote Controller

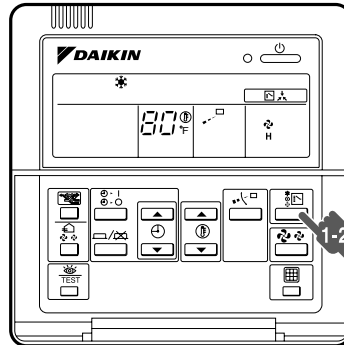

- When the system is installed as shown in figure 14 and 15, it is necessary to designate one of the remote controllers as the master remote controller.

### For RXYQ series

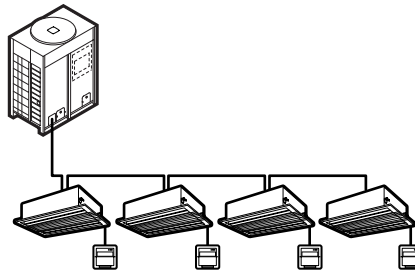

When one outdoor unit is connected with several indoor units.

### For REYQ series

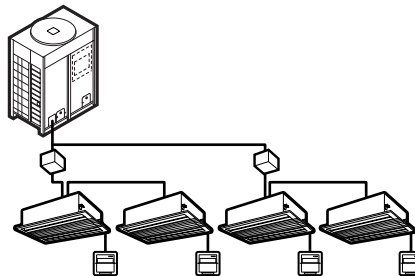

When one BS unit is connected with several indoor units.

- Only the master remote controller can select heating, cooling or automatic (only REYQ series) operation.
- The displays of slave remote controllers show “  ” (changeover under control) and they automatically follow the operation mode directed by the master remote controller.

However, it is possible to changeover to program dry operation with slave remote controllers if the system is in cooling operation set by the master remote controller.

**How to designate the master remote controller**

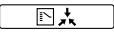
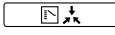
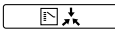
- 1** Press the operation mode selector button of the current master remote controller for 4 seconds.  
The display showing “  ” (changeover under control) of all slave remote controllers connected to the same outdoor unit or BS unit flashes.
- 2** Press the operation mode selector button of the controller that you wish to designate as the master remote controller. Then designation is completed. This remote controller is designated as the master remote controller and the display showing “  ” (changeover under control) vanishes.  
The displays of other remote controllers show “  ” (changeover under control).

## 5.6 Precautions for Group Control System or Two Remote Controller Control System

This system provides two other control systems beside individual control (one remote controller controls one indoor unit) system. Confirm the following if your unit is of the following control system type.

**■ Group control system**

One remote controller controls up to 16 indoor units. All indoor units are equally set.

**■ Two remote controller control system**

Two remote controllers control one indoor unit (in case of group control system, one group of indoor units). The unit is individually operated.

**Note:**

- Contact your Daikin dealer in case of changing the combination or setting of group control and two remote controller control systems.

## 6. Optimum Operation

Observe the following precautions to ensure the system operates properly.

- Adjust the air outlet properly and avoid direct air flow to room inhabitants.
- Adjust the room temperature properly for a comfortable environment. Avoid excessive heating or cooling.
- Prevent direct sunlight from entering a room during cooling operation by using curtains or blinds.
- Ventilate often.  
Extended use requires special attention to ventilation.
- Keep doors and windows closed. If the doors and windows remain open, air will flow out of your room causing a decrease in the cooling or heating effect.
- Never place objects near the air inlet or the air outlet of the unit. It may cause deterioration in the effect or stop the operation.
- Turn off the main power supply switch to the unit when the unit is not used for longer periods of time. If the switch is on, it uses electricity. Before restarting the unit, turn on the main power supply switch 6 hours before operation to ensure smooth running. (Refer to the chapter "Maintenance" in the indoor unit manual.)
- When the display shows “ ” (time to clean the air filter), ask a qualified service person to clean the filters. (Refer to the chapter "Maintenance" in the indoor unit manual.)
- Keep the indoor unit and remote controller at least 3.5ft. away from televisions, radios, stereos, and other similar equipment. Failing to do so may cause static or distorted pictures.

## 7. Following Symptoms are not Air Conditioner Troubles

### 7.1 The System does not Operate

- **The air conditioner does not start immediately after the ON/OFF button on the remote controller is pushed.**  
If the operation lamp lights, the system is in normal condition.  
To prevent overloading of the compressor motor, the air conditioner starts 5 minutes after it is turned ON again in case it was turned OFF just before. The same starting delay occurs after the operation mode selector button was used.
- **If “Centralized Control” is displayed on the remote controller and pressing the operation button causes the display to blink for a few seconds.**  
This indicates that the central device is controlling the unit.  
The blinking display indicates that the remote controller cannot be used.
- **The system does not start immediately after the power supply is turned on.**  
Wait one minute until the micro computer is prepared for operation.

### 7.2 Cool/heat cannot be Changed Over

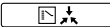
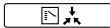
- **When the display shows “” (changeover under control), it shows that this is a slave remote controller.**
- **When the cool/heat changeover remote control switch is installed and the display shows “” (changeover under control).**  
This is because cool/heat changeover is controlled by the cool/heat changeover remote control switch. Ask your Daikin dealer where the remote control switch is installed.

### 7.3 Fan Operation is Possible, but Cooling and Heating do not Work

- **Immediately after the power is turned on.**  
The micro computer is getting ready to operate. Wait 10 minutes.

### 7.4 The Fan Strength does not Correspond to the Setting

- **The fan strength does not change even if the fan strength adjustment button is pressed.**  
During heating operation, when the room temperature reaches the set temperature, the outdoor unit goes off and the indoor unit changes to whisper fan strength.  
This is to prevent cold air blowing directly on occupants of the room.  
The fan strength will not change even if the button is changed, when another indoor unit is in heating operation.

### 7.5 The Fan Direction does not Correspond to the Setting

- **The fan direction does not correspond to the remote controller display.**  
**The fan direction does not swing.**  
This is because the unit is being controlled by the micro computer.



## 7.6 White Mist comes out of a Unit

### Indoor unit

- **When humidity is high during cooling operation.**

If the interior of an indoor unit is extremely contaminated, the temperature distribution inside a room becomes uneven. It is necessary to clean the interior of the indoor unit. Ask your Daikin dealer for details on cleaning the unit. This operation requires a qualified service person.

- **Immediately after the cooling operation stops and if the room temperature and humidity are low.**

This is because warm refrigerant gas flows back into the indoor unit and generates steam.

### Indoor unit, outdoor unit

- **When the system is changed over to heating operation after defrost operation.**

Moisture generated by defrost becomes steam and is exhausted.

## 7.7 Noise of Air Conditioners

### Indoor unit

- **A “zeen” sound is heard immediately after the power supply is turned on.**

The electronic expansion valve inside an indoor unit starts working and makes the noise. Its volume will reduce in about one minute.

- **A continuous low “shah” sound is heard when the system is in cooling operation or at a stop.**

When the drain pump (optional accessories) is in operation, this noise is heard.

- **A “pishi-pishi” squeaking sound is heard when the system stops after heating operation.**

Expansion and contraction of plastic parts caused by temperature change make this noise.

- **A low “sah”, “choro-choro” sound is heard while the indoor unit is stopped.**

When the other indoor unit is in operation, this noise is heard. In order to prevent oil and refrigerant from remaining in the system, a small amount of refrigerant is kept flowing.

### Indoor unit, outdoor unit

- **A continuous low hissing sound is heard when the system is in cooling or defrost operation.**

This is the sound of refrigerant gas flowing through both indoor and outdoor units.

- **A hissing sound which is heard at the start or immediately after stopping operation or defrost operation.**

This is the noise of refrigerant caused by flow stop or flow change.

### Outdoor unit

- **When the tone of operating noise changes.**

This noise is caused by the change of frequency.

## 7.8 Dust comes out of the Unit

- When the unit is used for the first time in a long time.  
This is because dust has gotten into the unit.

## 7.9 The Units can Give off Odours

- The unit can absorb the smell of rooms, furniture, cigarettes, etc., and then emit it again.

## 7.10 The Outdoor Unit Fan does not Spin

- During operation.  
The speed of the fan is controlled in order to optimize product operation.

## 7.11 The Display Shows “88”

- This is the case immediately after the main power supply switch is turned on and means that the remote controller is in normal condition. This continues for one minute.

## 7.12 The Compressor in the Outdoor Unit does not Stop after a Short Heating Operation

- This is to prevent oil and refrigerant from remaining in the compressor. The unit will stop after 5 to 10 minutes.

## 7.13 The Inside of an Outdoor Unit is Warm even when the Unit has Stopped

- This is because the crankcase heater is warming the compressor so that the compressor can start smoothly.

## 8. Troubleshooting

If one of the following malfunctions occur, take the measures shown below and contact your Daikin dealer.

**The system must be repaired by a qualified service person.**

- If a safety device such as a fuse, a breaker or an earth leakage breaker frequently actuates, or the ON/OFF switch does not properly work;  
Measure: Turn off the main power switch.
- If water leaks from unit;  
Measure: Stop the operation.
- If the display “ TEST ”, the unit number and the operation lamp flash and the malfunction code appears;

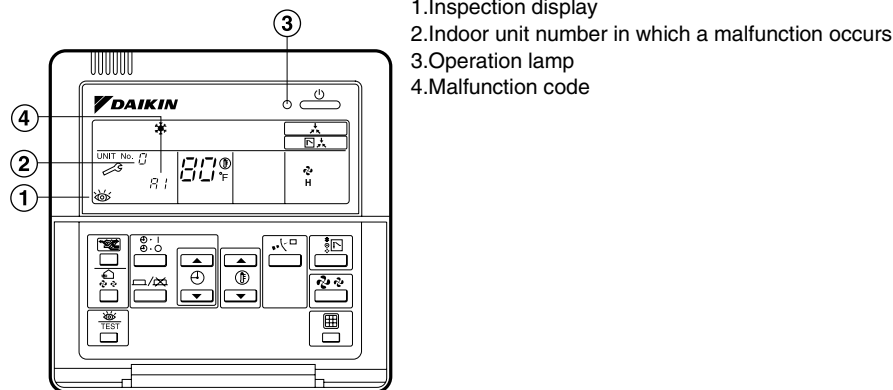

Measure: Notify your Daikin dealer and report the malfunction code.

**If the system does not properly operate except for the above mentioned cases and none of the above mentioned malfunctions is evident, investigate the system according to the following procedures.**

1. If the system does not operate at all;
  - Check if there is no power failure.  
Wait until power is restored. If power failure occurs during operation, the system automatically restarts immediately after the power supply is recovered.
  - Check if no fuse has blown or breaker has worked. Change the fuse or reset the breaker if necessary.
2. If the system goes into fan only operation, but as soon as it goes into heating or cooling operation, the system stops;
  - Check if air inlet or outlet of outdoor or indoor unit is not blocked by obstacles.  
Remove any obstacle and make it well-ventilated.
  - Check if the remote controller display shows “ ” (time to clean the air filter). (Refer to the chapter “Maintenance” in the indoor unit manual.)
3. The system operates but cooling or heating is insufficient;
  - Check if air inlet or outlet of outdoor or indoor unit is not blocked by obstacles.  
Remove any obstacle and make it well-ventilated.
  - Check if the air filter is not clogged. (Refer to the chapter “Maintenance” in the indoor unit manual.)
  - Check the temperature setting.
  - Check the fan speed setting on your remote controller.
  - Check for open doors or windows. Shut doors and windows to prevent wind from coming in.
  - Check if there are too many occupants in the room during cooling operation.

- Check if the heat source of the room is excessive.
- Check if direct sunlight enters the room.  
Use curtains or blinds.
- Check if the air flow angle is not proper.

# Part 5

## Precautions for new Refrigerant (R401A)

1. Precautions for New Refrigerant (R410A).....	216
1.1 Outline .....	216
1.2 Refrigerant Cylinders.....	217
1.3 Service Tools.....	218

# 1. Precautions for New Refrigerant (R410A)

## 1.1 Outline

### 1.1.1 About Refrigerant R410A

- Characteristics of new refrigerant, R410A
  1. Performance  
Almost the same performance as R22 and R407C
  2. Pressure  
Working pressure is approx. 1.4 times more than R22 and R407C.
  3. Refrigerant composition  
Few problems in composition control, since it is a Quasi-azeotropic mixture refrigerant.

Refrigerant name	HFC units (Units using new refrigerants)		HCFC units
	R407C	R410A	R22
Composing substances	Non-azeotropic mixture of HFC32, HFC 125 and HFC134a (*1)	Quasi-azeotropic mixture of HFC32 and JFC125 (*1)	Single-component refrigerant
Design pressure	3.2MPa (gauge pressure) = 464 psi	3.80 MPa (gauge pressure) = 550 psi	2.75MPa (gauge pressure) = 406 psi
Refrigerant oil	Synthetic oil (Ether)		Mineral oil (Suniso)
Ozone destruction factor (ODP)	0	0	0.05
Combustibility	None	None	None
Toxicity	None	None	None

- ★1. Non-azeotropic mixture refrigerant : mixture of two or more refrigerants having different boiling points.
- ★2. Quasi-azeotropic mixture refrigerant : mixture of two or more refrigerants having similar boiling points.
- ★3. The design pressure is different at each product. Please refer to the installation manual for each product.  
(Reference) 1 MPa  $\doteq$  145 psi

## 1.2 Refrigerant Cylinders

- Cylinder specifications
  - The cylinder is painted refrigerant color (pink).
  - The cylinder valve is equipped with a siphon tube.

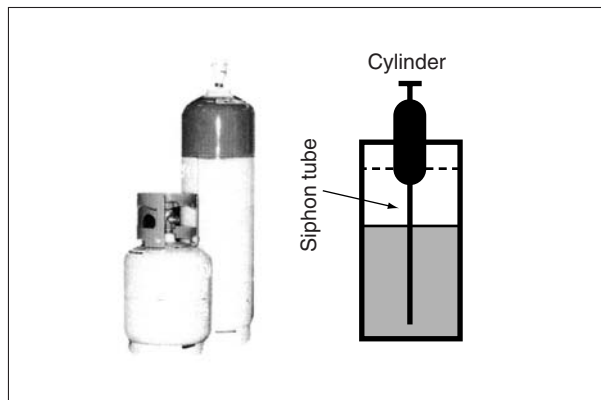

Refrigerant can be charged in liquid state with cylinder in upright position.

**Caution:** Do not lay cylinder on its side during charging, since it cause refrigerant in gas state to enter the system.

- Handling of cylinders
  - (1) Laws and regulations
 

R410A is liquefied gas, and the High-Pressure Gas Safety Law must be observed in handling them. Before using, refer to the High-Pressure Gas Safety Law.

The Law stipulates standards and regulations that must be followed to prevent accidents with high-pressure gases. Be sure to follow the regulations.
  - (2) Handling of vessels
 

Since R410A is high-pressure gas, it is contained in high-pressure vessels.

Although those vessels are durable and strong, careless handling can cause damage that can lead to unexpected accidents. Do not drop vessels, let them fall, apply impact or roll them on the ground.
  - (3) Storage
 

Although R410A is not flammable, it must be stored in a well-ventilated, cool, and dark place in the same way as any other high-pressure gases.

It should also be noted that high-pressure vessels are equipped with safety devices that releases gas when the ambient temperature reaches more than a certain level (fusible plug melts) and when the pressure exceeds a certain level (spring-type safety valve operates).

## 1.3 Service Tools

R410A is used under higher working pressure, compared to previous refrigerants (R22,R407C). Furthermore, the refrigerating machine oil has been changed from Suniso oil to Ether oil, and if oil mixing is occurred, sludge results in the refrigerants and causes other problems. Therefore, gauge manifolds and charge hoses that are used with a previous refrigerant (R22,R407C) can not be used for products that use new refrigerants.

Be sure to use dedicated tools and devices.

### ■ Tool compatibility

Tool	Compatibility			Reasons for change
	HFC		HCFC	
	R410A	R407C	R22	
Gauge manifold Charge hose	×			<ul style="list-style-type: none"> <li>Do not use the same tools for R22 and R410A.</li> <li>Thread specification differs for R410A and R407C.</li> </ul>
Charging cylinder	×		○	<ul style="list-style-type: none"> <li>Weighting instrument used for HFCs.</li> </ul>
Gas detector	○		×	<ul style="list-style-type: none"> <li>The same tool can be used for HFCs.</li> </ul>
Vacuum pump (pump with reverse flow preventive function)		○		<ul style="list-style-type: none"> <li>To use existing pump for HFCs, vacuum pump adaptor must be installed.</li> </ul>
Weighting instrument		○		
Charge mouthpiece	×			<ul style="list-style-type: none"> <li>Seal material is different between R22 and HFCs.</li> <li>Thread specification is different between R410A and others.</li> </ul>
Flaring tool (Clutch type)		○		<ul style="list-style-type: none"> <li>For R410A, flare gauge is necessary.</li> </ul>
Torque wrench		○		<ul style="list-style-type: none"> <li>Torque-up for 1/2 and 5/8</li> </ul>
Pipe cutter		○		
Pipe expander		○		
Pipe bender		○		
Pipe assembling oil		×		<ul style="list-style-type: none"> <li>Due to refrigerating machine oil change. (No Suniso oil can be used.)</li> </ul>
Refrigerant recovery device	Check your recovery device.			
Refrigerant piping	See the chart below.			<ul style="list-style-type: none"> <li>Only <math>\phi 19.1</math> is changed to 1/2H material while the previous material is "O".</li> </ul>

As for the charge mouthpiece and packing, 1/2UNF20 is necessary for mouthpiece size of charge hose.



## 1. Flaring tool



### ■ Specifications

- Dimension A

Unit:mm

Nominal size	Tube O.D. Do	A <sup>+0</sup> <sub>-0.4</sub>	
		Class-2 (R410A)	Class-1 (Conventional)
1/4	6.35	9.1	9.0
3/8	9.52	13.2	13.0
1/2	12.70	16.6	16.2
5/8	15.88	19.7	19.4
3/4	19.05	24.0	23.3

### ■ Differences

- Change of dimension A

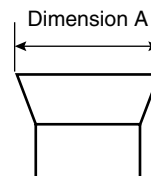

For class-1: R407C  
For class-2: R410A

Conventional flaring tools can be used when the work process is changed.  
(change of work process)

Previously, a pipe extension margin of 0 to 0.5mm was provided for flaring. For R410A air conditioners, perform pipe flaring with a pipe extension margin of 1.0 to 1.5mm.

(For clutch type only)

Conventional tool with pipe extension margin adjustment can be used.

**2. Torque wrench**



■ Specifications

- Dimension B Anytime

Nominal size	Class-1	Class-2	Previous
1/2	24	26	24
5/8	27	29	27

No change in tightening torque  
 No change in pipes of other sizes

■ Differences

- Change of dimension B  
 Only 1/2", 5/8" are extended

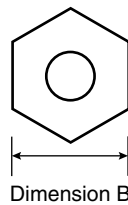

For class-1: R407C  
 For class-2: R410A

**3. Vacuum pump with check valve**

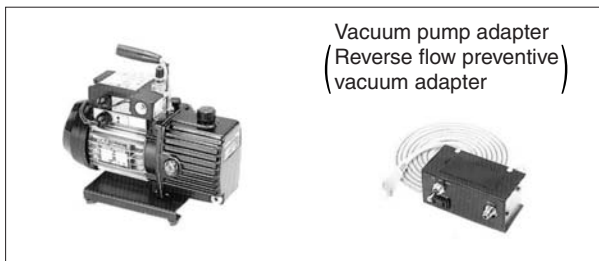

Vacuum pump adapter  
 (Reverse flow preventive)  
 vacuum adapter

■ Specifications

- Discharge speed
  - 50 l/min (50Hz)
  - 60 l/min (60Hz)
- Suction port UNF7/16-20(1/4 Flare)  
 UNF1/2-20(5/16 Flare) with adapter
- Maximum degree of vacuum  
 -100.7 kPa (5 torr - 755 mmHg)

■ Differences

- Equipped with function to prevent reverse oil flow
- Previous vacuum pump can be used by installing adapter.

#### 4. Leak tester



- Specifications
  - Hydrogen detecting type, etc.
  - Applicable refrigerants  
R410A, R407C, R404A, R507A, R134a, etc.
- Differences
  - Previous testers detected chlorine. Since HFCs do not contain chlorine, new tester detects hydrogen.

#### 5. Refrigerant oil (Air compal)



- Specifications
  - Contains synthetic oil, therefore it can be used for piping work of every refrigerant cycle.
  - Offers high rust resistance and stability over long period of time.
- Differences
  - Can be used for R410A and R22 units.

#### 6. Gauge manifold for R410A

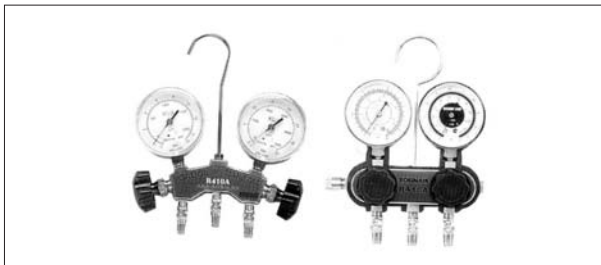

- Specifications
  - High pressure gauge  
- 0.1 to 5.3 MPa (-29.92 inHg to 738 psi)
  - Low pressure gauge  
- 0.1 to 3.8 MPa (-29.92 inHg to 530 psi)

- 1/4" → 5/16" (2min → 2.5min)
  - No oil is used in pressure test of gauges.  
→ For prevention of contamination
  - Temperature scale indicates the relationship between pressure and temperature in gas saturated state.
- Differences
- Change in pressure
  - Change in service port diameter

## 7. Charge hose for R410A

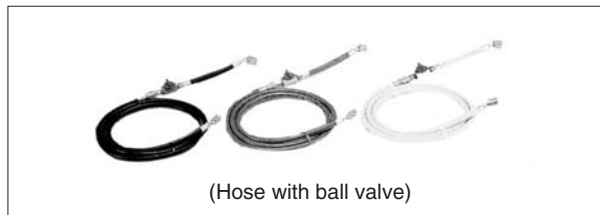

- Specifications
- Working pressure 5.08 MPa (736 psi)
  - Rupture pressure 25.4 MPa (3683 psi)
  - Available with and without hand-operate valve that prevents refrigerant from outflow.
- Differences
- Pressure proof hose
  - Change in service port diameter
  - Use of nylon coated material for HFC resistance

## 8. Charging cylinder

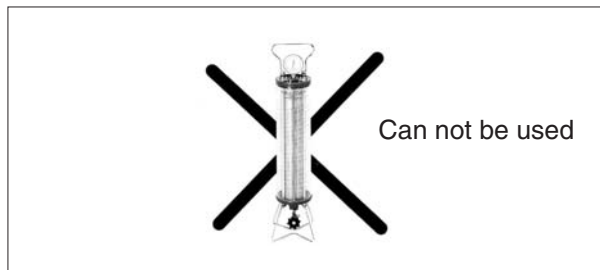

- Specifications
- Use weigher for refrigerant charge listed below to charge directly from refrigerant cylinder.
- Differences
- The cylinder can not be used for mixed refrigerant since mixing ratio is changed during charging.

When R410A is charged in liquid state using charging cylinder, foaming phenomenon is generated inside charging cylinder.

## 9. Weigher for refrigerant charge



- Specifications
  - High accuracy
    - TA101A (for 10-kg cylinder) =  $\pm 2\text{g}$
    - TA101B (for 20-kg cylinder) =  $\pm 5\text{g}$
  - Equipped with pressure-resistant sight glass to check liquid refrigerant charging.
  - A manifold with separate ports for HFCs and previous refrigerants is equipped as standard accessories.
- Differences
  - Measurement is based on weight to prevent change of mixing ratio during charging.

## 10. Charge mouthpiece



- Specifications
  - For R410A, 1/4" → 5/16" (2min → 2.5min)
  - Material is changed from CR to H-NBR.
- Differences
  - Change of thread specification on hose connection side (For the R410A use)
  - Change of sealer material for the HFCs use.



# Index

## Symbols

“88” cannot be cleared from the central remote controller ..... 130

## A

Additional Charge of Refrigerant..... 41  
 Additional Refrigerant Charge..... 156  
 Additional refrigerant operation setting ..... 82  
 Air Flow Direction Setting..... 72  
 Air Tight Test..... 32  
 Allowable Piping Length..... 101  
 Applicable Range of Field setting..... 70  
 Auto Restart after Power Failure Reset ..... 71

## B

Brazing..... 26

## C

Capacity precedence setting..... 83  
 Caution for Refrigerant Leaks ..... 169  
 Centralized Control Group No. Setting..... 74  
 Check Operation ..... 64, 95  
 Contents of Control Modes ..... 76  
 Continuous demand setting ..... 83  
 Control Wiring ..... 53  
 Cool/Heat Mode Switching..... 86  
 Cracks develop in field pipes due to thermal expansion and contraction ..... 128  
 Cylinder specifications ..... 217

## D

Defrost setting..... 82  
 Demand setting..... 83  
 Detailed Explanation of Setting Modes ..... 71  
 Drain pipe trap shape defective ..... 125  
 Drain Pipe Work (Indoor) ..... 43  
 Drain Piping for Each Model  
   Ceiling Mounted Built-in Type (FXSQ-M) ..... 48  
   Ceiling Mounted Cassette Type (FXFQ-M Multi-flow) ..... 46  
   Ceiling Mounted Duct Type (FXMQ-M) ..... 50  
   Concealed Floor Standing Type (FXNQ-M)..... 52  
   Floor Standing Type (FXLQ-M) ..... 52  
   Wall Mounted Type (FXAQ-M) ..... 51  
 Drain Trap ..... 43  
 Duct Work (Indoor)..... 56

## E

Electric Wiring Work..... 185  
 Electrical Specifications ..... 139  
 Electrical Work ..... 53

Emergency operation  
   (STD compressor is inhibited to operate.) .....82  
 Example of Connection.....151  
 Excessive noise due to incorrect angling  
   of REFNET joints .....127  
 External Appearance .....3  
 External low noise/demand setting .....82

## F

Field Setting.....68  
 Field Setting from Outdoor Unit .....78  
 Filter Sign Setting .....71  
 Flange Connection.....30  
 Flare Connection .....26  
 Flaring Procedure .....28

## H

Hand Over to Customer.....98  
 High static pressure setting .....82

## I

Installation.....13  
 Installation of Indoor Unit.....15  
 Installation of Outdoor Unit .....59

## L

Leak Test and Vacuum Drying .....153  
 Low noise setting .....83

## M

Mismatch between cables connecting indoor and outdoor units and corresponding piping .....124  
 Monitor mode.....84

## N

Night-time low noise operation end setting.....83  
 Night-time low noise operation start setting.....83  
 Night-time low noise setting.....82

## O

Operating Noise of Indoor Units .....99  
 Operation Mode .....77  
 Operation When Power is Turned On.....66  
 Outdoor Unit PC Board Layout.....67  
   Local setting switch .....67  
   Microcomputer normal monitor .....67  
   Mode setting switch.....67  
   Set mode display (LED) .....67

## P

Pipe size selection.....106  
 Piping Diameter for Grouped Drain Pipes .....45

Piping System Diagrams		VRV Inspection Sheet.....	114
BS Unit .....	120	<b>W</b>	
Indoor Unit .....	119	Wiring Diagrams .....	121
Outdoor Unit .....	118		
Power Supply .....	54		
Precautions for New Refrigerant (R410A).....	216		
Pressure down despite absence of leaks during			
air tight test .....	126		
Program Dry Operation .....	203		
<b>R</b>			
R410A .....	216		
REFNET header.....	24, 127		
REFNET joint .....	24		
REFNET joints .....	127		
Refrigerant Cylinders .....	217		
Refrigerant Leaks.....	96		
Refrigerant Pipe Work.....	20		
Refrigerant recovery mode setting .....	82		
<b>S</b>			
Selection of Location.....	56		
Sequential operation setting.....	82		
Service Space .....	58		
Service Tools .....	218		
Setting by dip switches.....	78		
Setting by pushbutton switches.....	79		
Setting Contents and Code No. ....	69		
Setting mode 1 .....	80		
Setting mode 2 .....	81		
Setting of Low Noise Operation and			
Demand Operation.....	87		
Setting of Operation Control Mode.....	76		
Setting of Refrigerant Additional			
Charging Operation.....	93		
Sleeve and Insert Work.....	14		
Specifications for Field Supplied Fuses and Wire... ..	186		
Step by Step Installation Procedure.....	13		
<b>T</b>			
Tc setting.....	82		
Te setting .....	82		
Technical Specifications.....	138		
Test Operation			
Procedure and Outline.....	63		
The centralized control group			
number cannot be set .....	129		
Thermal Insulation Work .....	31		
Transmission wiring between the cool/heat			
selector and the outdoor unit is too close to			
a high voltage wire .....	129		
<b>U</b>			
Ultra-Long-Life Filter Sign Setting .....	71		
<b>V</b>			
Vacuum Drying.....	34		



# Drawings & Flow Charts

## Symbols

“88” cannot be cleared from the central remote controller ..... 130

## A

a free flow of air back and forth ..... 97  
 Accessories ..... 137, 176  
 Additional Charge of Refrigerant  
   Operational steps ..... 41  
   Refrigerant Charging Instructions ..... 41  
   Siphon tube ..... 42  
 Additional refrigerant charge total flow ..... 93  
 Adjusting the Air Flow Direction ..... 205  
 Air Tight Test  
   Checking for Leaks ..... 33  
   Compensating adjustment value ..... 32  
   Operational steps ..... 32  
 Allowable Piping Length ..... 101

## B

Before Installation ..... 179  
 Branch with refnet header ..... 103  
 Branch with refnet joint and refnet header ..... 102  
 Brazing ..... 26  
 BS Unit ..... 180

## C

Calculate the additional refrigerant to be charged ..... 107  
 Calculate the smallest room volume ..... 170  
 Calculating Operating Noise ..... 100  
 Calibration method ..... 37  
 Caution for Refrigerant Leaks ..... 96  
 Caution label ..... 62  
 Ceiling Mounted Built-in Type (FXSQ-M)  
   drain hose ..... 48  
   Drain Piping ..... 48  
   DRAIN RAISING PIPING ..... 48  
   drainage flow ..... 49  
   ELECTRIC WIRING WORK ..... 49  
   multiple drain pipes ..... 49  
 Ceiling Mounted Cassette Type (FXFQ-M Multi-flow)  
   DRAIN RAISING PIPING ..... 46  
   Indoor drain pipe ..... 46  
   multiple drain pipes ..... 46  
   Rig drain piping ..... 46  
   Terminal box lid ..... 47  
 Ceiling Mounted Duct Type (FXMQ-M) ..... 50  
 Centralized Control Group No. Setting  
   Group No. Setting Example ..... 75  
 Change of dimension A ..... 219

Change of dimension B ..... 220  
 Charge hose for R410A ..... 222  
 Charge mouthpiece ..... 223  
 charging additional refrigerant ..... 157  
 Charging cylinder ..... 222  
 CHECK OPERATION FUNCTION ..... 95  
 Check points ..... 10  
 Choice of Materials for Refrigerant Piping ..... 24  
 Closing shutoff valve ..... 154  
 Coat the flange sheet surface with refrigeration oil ..... 30  
 Coat the inner and outer surface of the flare with  
   refrigerator oil ..... 27  
 connecting the ground ..... 163  
 Contents of Control Modes  
   How to Select Operation Mode ..... 77  
 Contract Drawing ..... 9  
 Control circuit diagram ..... 12  
 Correlation of nozzle tip and size of  
   refrigeration piping ..... 25  
 Covering of Refrigerant Pipes  
   Particular care ..... 22  
   Pinching method ..... 22  
   Taping method ..... 22  
 Cracks develop in field pipes due to thermal  
   expansion and contraction ..... 128

## D

Degree of vacuum ..... 36  
 DO NOT USE STANDS TO SUPPORT THE  
   CORNERS ..... 144  
 Drain pipe trap shape defective ..... 125  
 Drain Pipe Work (Indoor)  
   Drain Pipe Gradient and Support ..... 43  
   Drain Trap ..... 43  
   Grouped Drain Piping ..... 44  
   Operational steps ..... 43  
   Use of an Auxiliary Drain Hose (Flexible) ..... 44  
 Drain Piping for Each Model  
   Ceiling Mounted Built-in Type (FXSQ-M) ..... 48  
   Ceiling Mounted Cassette Type  
     (FXFQ-M Multi-flow) ..... 46  
   Ceiling Mounted Duct Type (FXMQ-M) ..... 50  
   Concealed Floor Standing Type (FXNQ-M) ..... 52  
   Floor Standing Type (FXLQ-M) ..... 52  
   Wall Mounted Type (FXAQ-M) ..... 51  
 Duct Work (Indoor)  
   Operational steps ..... 56  
   Taking Account of Noise and Vibration ..... 56

## E

electric parts box ..... 180

Electrical Work	
a PCB for remote control, multiple core cable must not be used .....	53
Choosing a circuit breaker .....	54
Earthing .....	55
When cable more than 1.25 mm <sup>2</sup> is used .....	53
Example for the Whole System .....	185
example in case of refnet joint B .....	104, 105
example in case of refnet joint C .....	104, 105
example in the case of refnet header .....	104, 105
Example of Connection	
Branch with refnet header .....	151
Branch with refnet joint .....	151
Branch with refnet joint and refnet header .....	151
EXAMPLE OF TRANSMISSION	
LINE CONNECTION .....	188
Example of Transmission Line Connection .....	86
Excessive noise due to incorrect angling of REFNET joints .....	127
<b>F</b>	
Field line connection .....	161, 163
Field Setting From Outdoor Unit	
Mode changing procedure .....	79
filling the tank .....	157
Flare Gauge .....	27
flare shape .....	155
Flaring Procedure .....	28
Flaring tool .....	219
foundation bolts .....	144
Front connection .....	147
<b>G</b>	
Gauge manifold for R410A .....	221
Gist of Field Line Connection .....	186
<b>H</b>	
Hand Over to Customer	
Important Points .....	98
Make the service contact address clear .....	98
Operational Steps .....	98
How these installation problems affect an equipment .....	7
<b>I</b>	
Inspecting and Handling the Unit .....	58, 143
Installation of Indoor Unit	
Operational steps .....	15
Direction .....	16
Installation of Outdoor Unit	
Bolt pitch .....	59
Operational steps .....	59
interconnecting wiring .....	165
<b>K</b>	
Knock hole .....	147
knock holes .....	164
<b>L</b>	
laying power wiring .....	162
Leak Test and Vacuum Drying .....	153
Leak tester .....	221
<b>M</b>	
Maximum concentration level .....	96, 169
Mismatch between cables connecting indoor and outdoor units and corresponding piping .....	124
Movement of the air flow flap .....	205
<b>N</b>	
Name and Function of Each Switch and Display .....	198
Names and functions of parts .....	197
<b>O</b>	
Outdoor Unit PC Board Layout .....	67
<b>P</b>	
passing piping out through the front .....	145
Picking power line and transmission line .....	164
Pipe Insulation .....	156
Pipe size	
Piping between refrigerant branch kits .....	106
Piping Connection .....	184
Piping System Diagrams	
BS Unit .....	120
Indoor Unit .....	119
Outdoor Unit .....	118
Positioning of indoor unit .....	6
Positioning of outdoor unit .....	5
Power supply connection .....	167
Precautions when selecting branch piping .....	149
Pressure down despite absence of leaks during air tight test .....	126
pressure regulator .....	148
Program Dry Operation .....	203
Programming Start and Stop of the System with Timer .....	206
<b>R</b>	
REFNET Header .....	111, 112
REFNET Joint .....	109, 112, 148
Refrigerant Cylinders .....	217
refrigerant gas leak .....	182
Refrigerant oil (Air compal) .....	221
Refrigerant Pipe Flushing	
Fit blanking plugs .....	23
Flushing .....	24
Open the main valve .....	23
Set pressure regulator on nitrogen cylinder .....	23
Refrigerant Pipe Work	
Air tight .....	20
Clean .....	20
Dry .....	20
Operational steps .....	20
The 3 Principles of Refrigerant Piping .....	20

Refrigerant Piping ..... 146

## S

Selecting Installation Site ..... 178

Selection of Location ..... 141

AM broadcasting ..... 57, 141

servicing and the minimum space ..... 56, 141

Service Space ..... 58

Service Space for Indoor Units ..... 17

Set the flaring tool ..... 26

Setting of Air Flow Direction Adjustment Range ..... 73

Setting of Demand Operation ..... 89

Image of operation in the case of A ..... 90

Image of operation in the case of A and B ..... 90

Image of operation in the case of B ..... 90

Setting of Low Noise Operation ..... 87

Image of operation in the case of A ..... 88

Image of operation in the case of A, B ..... 88

Image of operation in the case of B ..... 88

Setting the Master Remote Controller ..... 207

Side (bottom) connection ..... 147

Signal interference due to use of  
multiple core cable ..... 123

Sleeve and Insert Work

Operational steps ..... 14

Steel insert ..... 15

Through holes in a reinforced concrete beam .... 14

Sound pressure rise due to room reverberation ..... 99

Special vacuum drying time chart ..... 40

Standard Operation Limit ..... 136

standard work practice for all brazing work ..... 21

System example ..... 161

## T

The analysis of major installation problems  
experienced during the year of 1988 ..... 7

The centralized control group number  
cannot be set ..... 129

The unit must be installed on a solid longitudinal  
foundation ..... 144

The use of "hard solder" is essential ..... 25

Thermal Insulation Work (Refrigerant Piping)

Essential Points of Thermal Insulation ..... 31

Heat Recovery Series ..... 32

Operational steps ..... 31

Tighten the bolts in opposite corners first to ensure that  
the connection is true ..... 30

Torque wrench ..... 220

Transmission wiring between the cool/heat  
selector and the outdoor unit is too close  
to a high voltage wire ..... 129

## U

Unpacking and Placing the Unit ..... 60

DO NOT USE STANDS TO SUPPORT THE  
CORNERS ..... 60

foundation bolts ..... 60

passing piping out through the front ..... 61

The unit must be installed on a solid longitudinal  
foundation ..... 60

## V

Vacuum Drying ..... 34

Vacuum Drying Procedure ..... 38

Vacuum pump with check valve ..... 220

VRV Inspection Sheet ..... 114

## W

Weigher for refrigerant charge ..... 223

Where there are no smaller room divisions ..... 97

Wired Remote Controller ..... 68

Wiring Diagram

Field Wiring ..... 122

Wiring Diagrams ..... 121

Field Wiring ..... 122

Outdoor Unit ..... 121

with cool/heat changeover ..... 202

without cool/heat changeover ..... 201

**Warning**



- Ask a qualified installer or contractor to install this product. Do not try to install the product yourself. Improper installation can result in water or refrigerant leakage, electrical shock, fire or explosion.
- Use only those parts and accessories supplied or specified by Daikin. Ask a qualified installer or contractor to install those parts and accessories. Use of unauthorized parts and accessories or improper installation of parts and accessories can result in water or refrigerant leakage, electrical shock, fire or explosion.
- Read the User's Manual carefully before using this product. The User's Manual provides important safety instructions and warnings. Be sure to follow these instructions and warnings.

For any inquiries, contact your local distributor.

### Cautions on product corrosion

1. Air conditioners should not be installed in areas where corrosive gases, such as acid gas or alkaline gas, are produced.
2. If the outdoor unit is to be installed close to the sea shore, direct exposure to the sea breeze should be avoided and choose an outdoor unit with anti-corrosion treatment.



The air conditioners manufactured by Daikin Industries have received **ISO 9000 series** certification for quality assurance.

**Certificate Number.**  
(ISO9001) **JMI-0107** (ISO9002) **JQA-1452**  
**JQA-0495**



All Daikin Industries locations and subsidiaries in Japan have received environmental management system standard **ISO 14001** certification.

**Daikin Industries, Ltd.**  
**Domestic Group**  
Certificate Number. EC99J2044

#### About ISO 14001

ISO 14001 is the standard defined by the International Organization for Standardization (ISO) relating to environmental management systems. Our group has been acknowledged by an internationally accredited compliance organisation as having an appropriate programme of environmental protection procedures and activities to meet the requirements of ISO 14001.

### Dealer

#### **DAIKIN U.S. CORPORATION**

375 Park Avenue, Suite 3308  
New York, N.Y.10152

[info@daikinac.com](mailto:info@daikinac.com)  
[www.daikinac.com](http://www.daikinac.com)

©All rights reserved