



# intelligent **Manager III**

## Operation Manual



Model names and specifications or the like are subject to change without prior notice for further improvement, so be sure to confirm the following catalogues and engineering data.



5.4.10	Renaming a Schedule.....	45
5.5	Interlocking Function .....	46
5.5.1	Setting up an Interlocking Program.....	47
5.5.2	Setting up Emergency Stop Programs.....	51
5.6	Data Management.....	56
5.6.1	The Building Management applications .....	56
5.6.2	Configuring the tenants .....	58
5.6.2.1	Creating a Tenant .....	58
5.6.2.2	Modifying a tenant .....	58
5.6.2.3	Removing a tenant.....	59
5.6.2.4	Exiting the report setup application.....	60
5.6.2.5	Creating a report.....	60
5.6.3	Graphical Report.....	62
5.6.3.1	Introduction .....	62
5.6.3.2	Starting the Graph function.....	63
5.6.3.3	Setting up "Graphs" .....	63
5.6.3.4	Drawing a graph .....	68
5.6.3.5	Printing a graph .....	71
5.6.3.6	Exporting a graph data .....	72
5.6.4	Setup of Power Proportional Distribution (option).....	72
5.7	System options.....	74
5.7.1	Configuring Management Groups.....	75
5.7.2	Configuring Control Groups .....	79
5.7.3	Configuring user Login.....	82
5.7.3.1	Fundamentals .....	82
5.7.3.2	Creating a user .....	85
5.7.3.3	Modifying a user .....	87
5.7.3.4	Deleting a user.....	87
5.7.4	Editing Management Points .....	88
5.7.5	Setting up Central control .....	88
5.7.6	Configuring the Buzzers.....	90
5.7.7	Configuring History options.....	91
5.7.8	Adjusting the Time .....	91
5.7.9	Enabling Confirmation Dialog .....	92
5.7.10	Setting up the Daylight saving time.....	93
5.7.11	Automatic Change Over.....	94
5.7.12	Sliding Temperature.....	95
5.7.13	Temperature Limit.....	96
5.7.14	Heating Mode Optimization.....	97
5.8	Moving between Screens .....	98
5.8.1	Simple Movement .....	99
5.8.2	Movement by Reservation Button.....	99
5.8.3	Automatic Circular Sequence .....	100
5.9	Malfunction Display and History Management.....	102
5.9.1	Displaying Malfunction Messages.....	102
5.9.2	Operator History Display Function .....	103
5.9.3	Detailed History Screen .....	105
5.10	Energy saving functions (Option) .....	107
5.10.1	Power Limit Control.....	107
5.10.1.1	Setting the power limit .....	107
5.10.1.2	Setting the control parameters.....	108
5.10.2	Setting up Eco Mode.....	110
5.10.2.1	Setting up Intermittent operation control.....	110
5.10.2.2	Setting up outdoor unit capacity control.....	112
5.11	Web Functions (Option) .....	114

---

5.11.1	Web Setting .....	114
5.11.1.1	Web Access Restriction Setting .....	115
5.11.1.2	Web Setting .....	116
5.11.2	E-Mail Setting .....	117
5.11.2.1	Setup items for the E-mail transmission .....	118
5.11.2.2	E-mail transmission timing.....	119
5.11.2.3	E-mail format .....	120
5.11.2.4	Trial mail .....	120
5.11.2.5	Operational Procedure .....	121
5.11.2.6	Setting of E-mail - SMTP sever setting - .....	121
5.11.2.7	Setting of E-mail - POP before SMTP setting - .....	122
5.11.2.8	Setting of E-mail - Transmission setting - .....	123
5.11.2.9	Setting of E-mail –Mail address setting - .....	124
5.11.2.10	Setting of E-mail .....	125
6.	Database Maintenance .....	127
7.	Troubleshooting .....	130



## 1. Before use

### 1.1 The features of intelligent Manager

Most operations are possible by a mere click of the left mouse button!

Although intelligent Manager may be operated via keyboard input of characters or numerals onto a set-up screen, all usual monitoring and control can be carried out using only the mouse.

All operations – indicated on the screen by clicking a button, partially displaying a management point list, displaying a pull-down menu, selecting one icon or a single item from a detailed menu – may be carried out by moving the mouse pointer to the appropriate place and single-clicking the left mouse button.

If intelligent Manager is started up from a desktop computer screen, some operations may need to be accessed by a double-click (two clicks in quick succession).

Hereafter throughout this document, buttons displayed on the screen will be depicted enclosed within a rectangle, ex: **Start**.

### 1.2 Important Notes

**Please ensure that the PC software is always started up and that the energy-saving mode has not been enabled.**

If the energy-saving mode has been set up, information generated may not be recorded in intelligent Manager.

**Do not install other application software.**

intelligent Manager software is designed exclusively for monitoring. Please be aware that, as the installation of other OA software may cause interference, we would be unable in such a case to guarantee correct functioning.

**Switchover to UPS (Uninterruptible Power Supply) and Automatic Shutdown in the case of power failure.**

If the system has switched over to UPS and usual power supply has not been restored after a predetermined duration, intelligent Manager automatically shuts down. However, if other application software is started up, the PC power supply may be cut off before the correct shutdown procedure has been carried out, resulting in operational data not being properly saved.

**Use 'small font' size.**

intelligent Manager requires that a 'small font' be used. (To set up and check: click the right mouse button in the background of Windows > select properties > display details > font size > select 'small font').

### 1.3 Functional Outline of intelligent Manager

---

**Note** Depending on the organization of your system, some functions may be inaccessible.

---

Type	Name	Outline
Monitoring	<ul style="list-style-type: none"> <li>- Management Point State Monitoring</li> <li>- Analog Maximum/Minimum Limit Monitoring</li> </ul>	<ul style="list-style-type: none"> <li>- Monitors state of management points (operation mode, abnormalities).</li> <li>- Monitors any excess of the pre-determined maximum/minimum measured values of analog management points.</li> </ul>
Display	<ul style="list-style-type: none"> <li>- Management Point State Display</li> <li>- Control Group Display</li> <li>- History Display</li> </ul>	<ul style="list-style-type: none"> <li>- Displays information related to management points.</li> <li>- Displays the history of malfunctions detected in the system, warnings, conditions, start/stop operations.</li> <li>- Displays each control group.</li> </ul>
Operation	<ul style="list-style-type: none"> <li>- Individual Start/Stop</li> <li>- Control Group Collective Start/Stop</li> <li>- Operation Mode Setup</li> <li>- Temperature Setup</li> <li>- Remote Control Operation Setup</li> <li>- Reset Filter Sign</li> <li>- Centralized Control Setup</li> </ul>	<ul style="list-style-type: none"> <li>- Starts/stops each management point individually.</li> <li>- Collects more than one management point together (control group) and performs collectively starts and stops a control group.</li> <li>- Sets up air-conditioner operation mode (fan, cooling, heating).</li> <li>- Sets up temperature of air-conditioner.</li> <li>- Sets up air-conditioner action mode via remote control instructions.</li> <li>- Resets air-conditioner filter sign.</li> <li>- Sets up permission/prohibition of user operation via centralized control equipment.</li> </ul>
Control	<ul style="list-style-type: none"> <li>- Schedule Control</li> <li>- Interlocking Control</li> <li>- (In case of fire etc.) Emergency Stop Control</li> <li>- Power failure release control</li> </ul>	<ul style="list-style-type: none"> <li>- Carries out control of management points in accordance with a setup schedule/.</li> <li>- Interlocks operation state, error state etc. of a given management point to control other management points and groups.</li> <li>- When the emergency signal is received, carries out (emergency stop) control for emergency alert and to prevent spread of fire etc.</li> <li>- Carries out management point control in accordance with the state and setup before power failure when power is restored.</li> </ul>
Measuring	<ul style="list-style-type: none"> <li>- Automatic Meter Reading</li> <li>- Operation Time &amp; Cumulative Number of Start/Stop</li> <li>- Analog Measuring (projected)</li> </ul>	<ul style="list-style-type: none"> <li>- Deals with cumulative pulse values of electric power, water, gas meters etc.</li> <li>- Cumulates equipment operation time, number of Start/Stop to facilitate maintenance.</li> <li>- Measures, displays and monitors temperature, humidity, pressure, voltage, amperage etc.</li> </ul>

Type	Name	Outline
Client Data Management	<ul style="list-style-type: none"> <li>- Simple Tenant Management</li> <li>- Collected Measurement Data</li> </ul>	<ul style="list-style-type: none"> <li>- Links management points with tenants.</li> <li>- Retrieves itemized data of tenant-linked management points.</li> </ul>
Misc.	<ul style="list-style-type: none"> <li>- Screen Movement</li> <li>- Password Setup</li> <li>- Support Function for Creation of Management Groups</li> <li>- Support Function for Creation of Control Groups</li> <li>- Switching between Celsius and Fahrenheit</li> </ul>	<ul style="list-style-type: none"> <li>- Enables reservation for movement between screens at will.</li> <li>- Carries out password setup/confirmation to confirm operation authority.</li> <li>- Enables creation/deletion of management groups and registration/modification of management points within a management group.</li> <li>- Enables creation/deletion of control groups and registration/modification of management points within a control group.</li> <li>- Temperature can be displayed in either Celsius or Fahrenheit.</li> </ul>
Remote access	<ul style="list-style-type: none"> <li>- Web function (option)</li> </ul>	<ul style="list-style-type: none"> <li>- Air conditioner can be monitored and operated via Web browser on PC in the network.</li> <li>- Schedule can be set via Web browser.</li> <li>- Notifies by mail when any malfunction is found.</li> </ul>
Monitor malfunction remotely	<ul style="list-style-type: none"> <li>- E-mail function (option)</li> </ul>	<ul style="list-style-type: none"> <li>- If a malfunction occurs, the occurrence date and time, the air conditioner, and the malfunction code are sent to the preset E-mail address.</li> <li>You can set up to three E-mail addresses.</li> </ul>



## 2. Basic Screen and Screen Directory

### 2.1 Basic Screen Layout

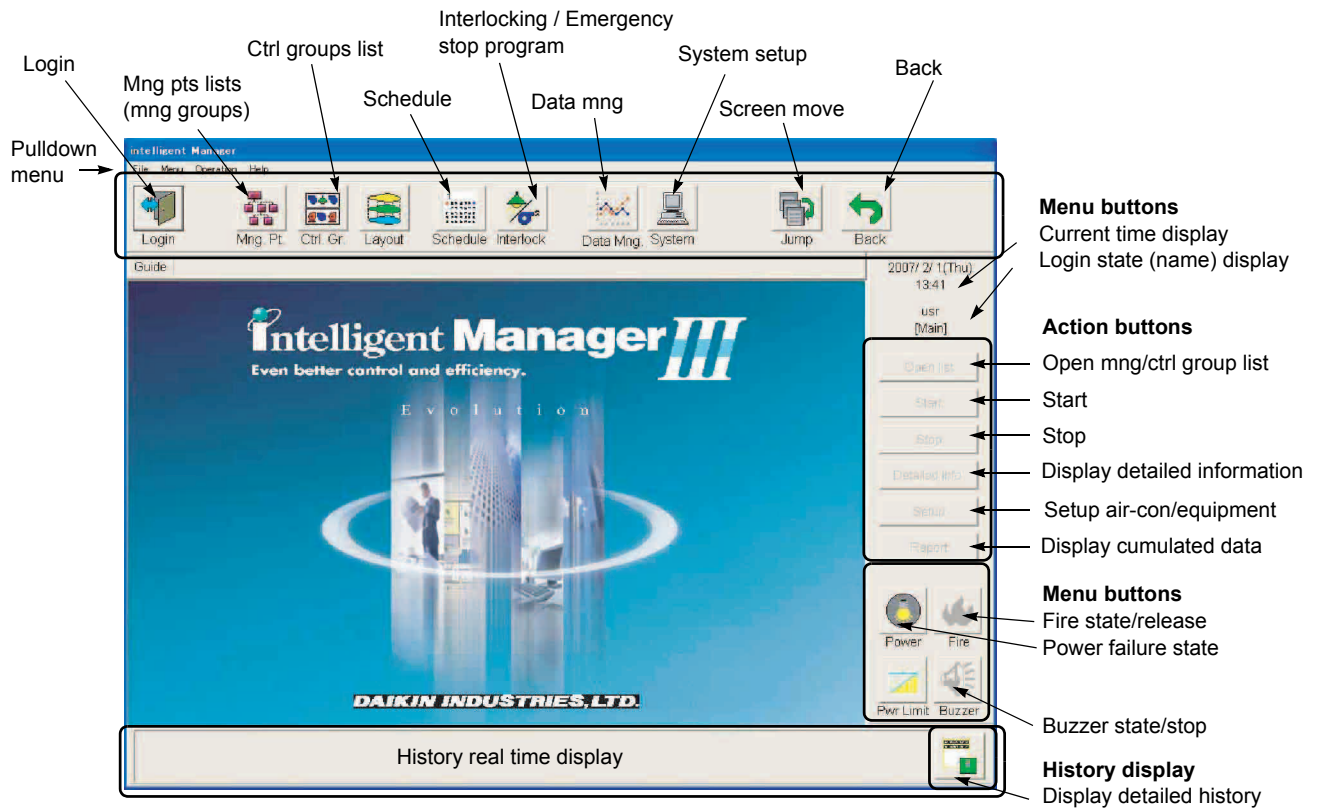

This consists of: menu buttons, action buttons, the message window and the working area.

**Menu buttons:** buttons used to call up various functions. They are operational at all times and in any screen menu.

**Action buttons:** buttons used to govern operations such as 'start' and 'stop'.

**Message window:** the window in which history abnormalities are displayed in real time.

**Working area:** the area in which the functions called up by the menu buttons are displayed.

The pull-down menu may be used to execute the functions of menu buttons and action buttons.

#### Action Buttons

An action button is enabled only when it can be operated according to a selected management point, control group or management group. When it is not operational, it is displayed in light gray, thereby indicating the operation's disabled state (gray-out).

An action button can be clicked, but not operated without operation authority (a warning will appear).

When an action button is clicked and an operation applied to an air-conditioner or equipment (start, stop, setup), a confirmation dialog appears to prevent incorrect operation (this dialogue display can be deactivated by initial setup).

If the **Back** button is clicked, it will revert to the screen displayed immediately beforehand.

## 2.2 Screen Directory

In a dialog, when **OK** and **Cancel** buttons exist, the operation may be cancelled. However, when an operation within a dialog may not be cancelled a warning appears to this effect. If the operation is pursued, the **Cancel** button is grayed out and cancellation is no longer an option.

If buttons such as **Open list** or **Detail** are selected from a functional menu screen, the screen will appear as in the structure shown below.

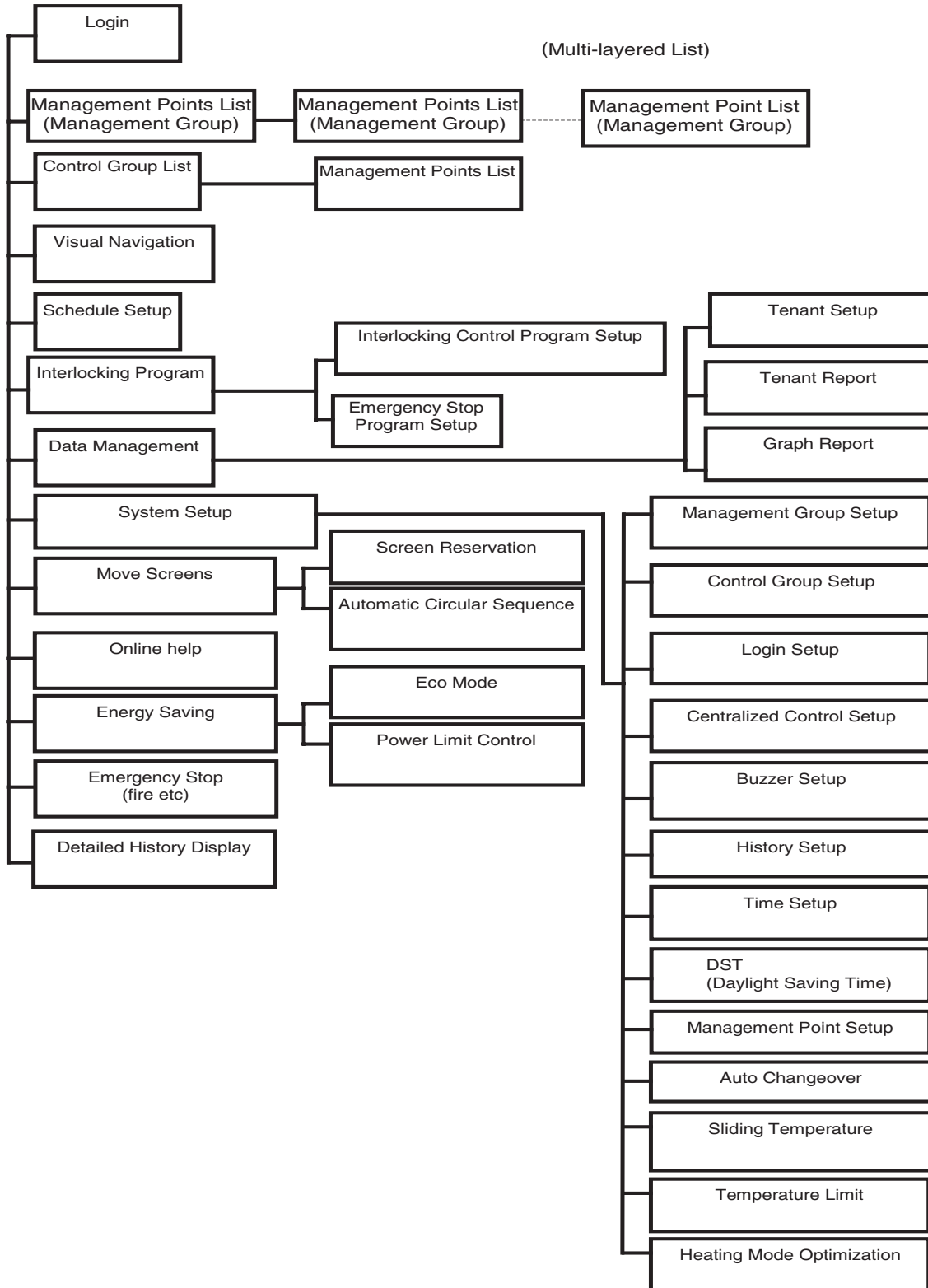

**Note** Depending on the organization of your system (user login and function access restriction), some functions shown in the figure below may be inaccessible. Those buttons with functions that cannot be used are either grayed out or will display the warning below.

---

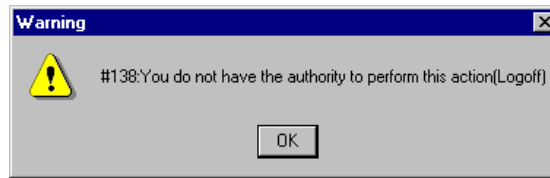

### 3. Starting and Stopping Operation of intelligent Manager

#### 3.1 Starting operation

intelligent Manager starts up automatically when the PC power supply is turned on, as shown below.

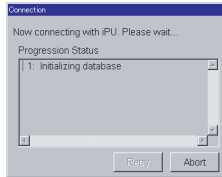

During the booting procedure, a progression status window appears. The booting time is function of the configuration (number of automatic control programs, etc.) and can last from a few seconds up to more than one minute.

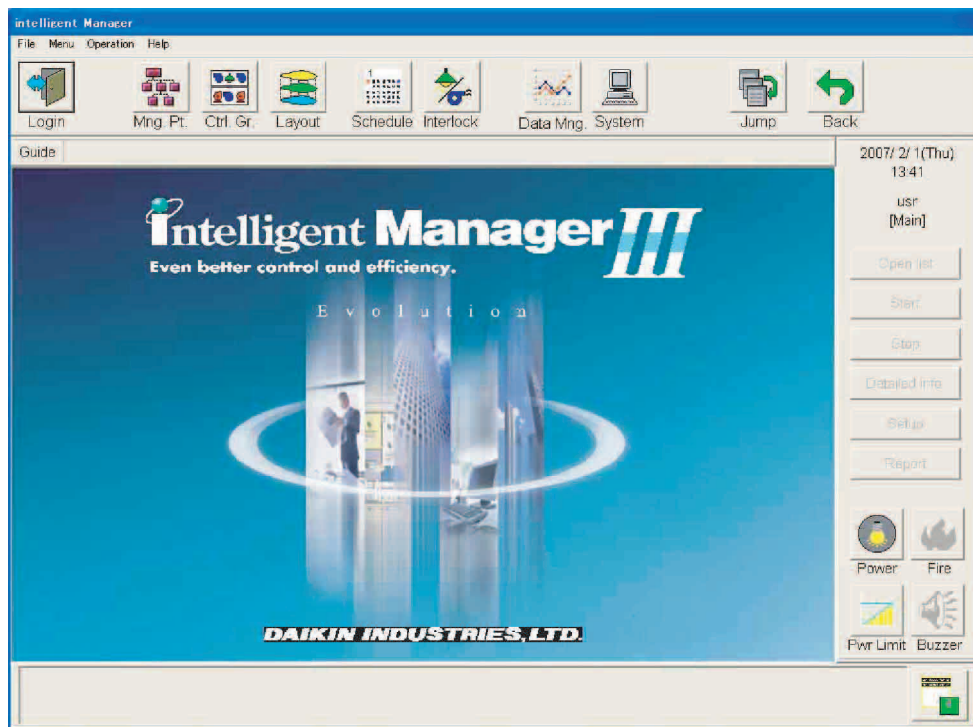

(Screen immediately after start up)

In the case of manual start up, double-click on the 'intelligent Manager' icon of the desktop or select 'intelligent Manager' from the Start Menu.



Double-click on the icon

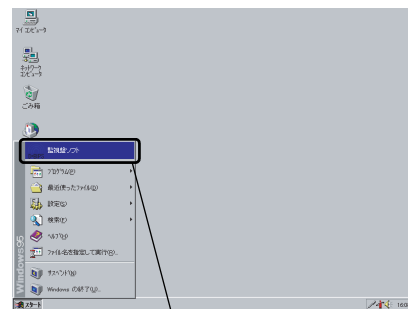

Select 'intelligent Manager'

### 3.2 Stopping Operation (up to Power Supply OFF)

Turning off the PC power supply must be done in two stages: exiting intelligent Manager and exiting Windows.

To exit intelligent Manager

Select **Exit intelligent Manager** from the File Menu.

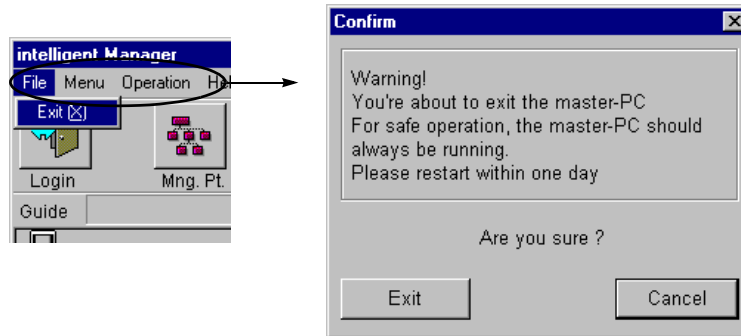

A dialog box will be displayed as shown above.

Click on the **Exit** button to exit intelligent Manager.

As the system is intended to operate constantly, if exited it should be restarted within one day.

Windows can then be exited.

### 3.3 Power Failure management: automatic Stop/Restart

The intelligent Manager is designed for continuous operation. Therefore, automatic shutdown is carried out in the case of power failure lasting more than about 10 minutes. As well, automatic restart can be carried out when the power has been restored.

When the iManager detects a signal of power failure, the state of the power indicator changes as shown below:

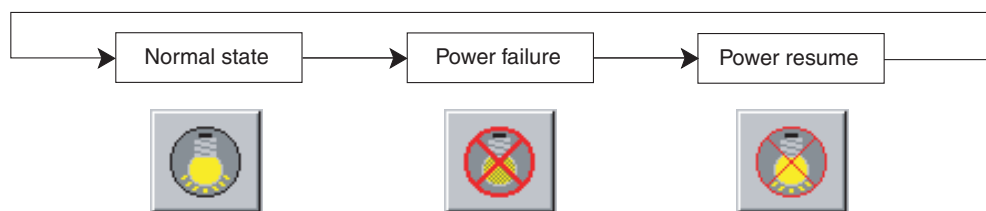

When the power failure occurs, the data of the Station are saved locally (operation state of management points, etc.). When the power is restored, the data are read out from the memory so that the system can be restarted in its previous state. During this time period (about 10 minutes), automatic control functions of the intelligent Manager system are deactivated (scheduling, interlocking and emergency stop programs).

### 3.4 Emergency Stop Management : Fire state/release

When an Emergency Stop signal is received, the state of the fire icon will change. During an emergency, clicking on the fire icon will display the dialog for carrying out forced release.

**[Forced Release]**

If the Emergency Stop signal turns out to be a false alarm (such as test run or under maintenance), a forced release function can be used.

If the Emergency Stop program is specified from the monitoring software and the [forced release] performed manually, the Emergency Stop program will be canceled irrespective of the release mode (automatic/manual) setup.

In the case of a program monitoring multiple input, even if a separate monitoring signal appears after forced release has been carried out, the emergency stop will not be started up.

(If all signals have not been turned off following the forced release, the emergency stop will not be restarted up).

Operation authority is required to carry out release (forced/manual) operations.

Please refer to **5.7.3 Configuring user Login** (p. 82).

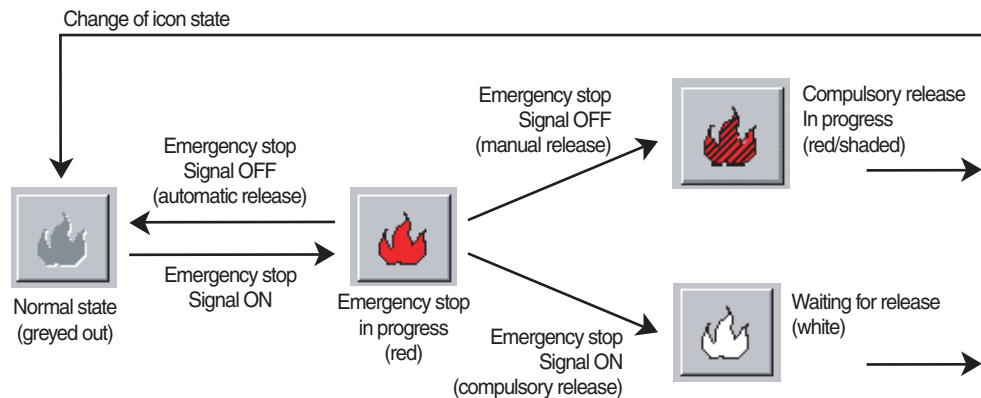

To execute release, select activated Emergency Stop program and click **Release** button.

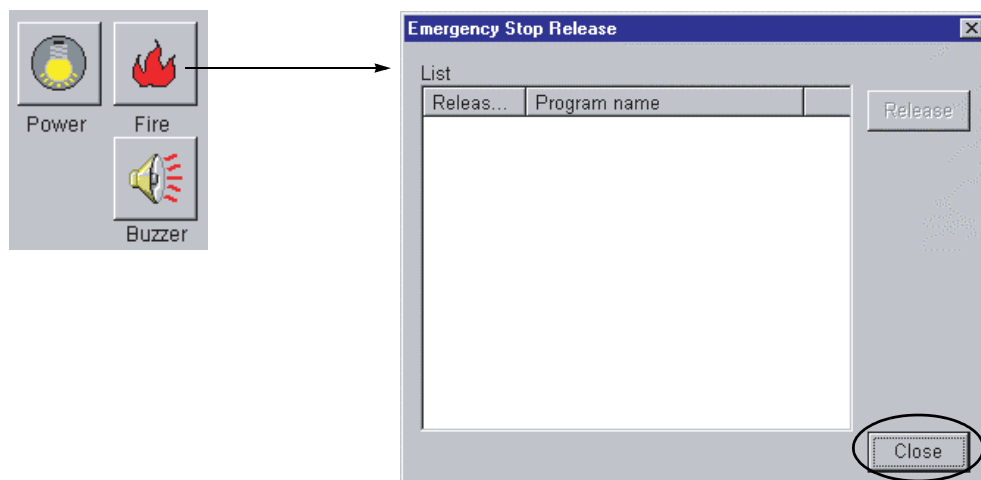

## 4. Logging in/Logging out

intelligent Manager may be operated in accordance with the range of authority selected by the user when logging in. (If login is not carried out, functions are confined to monitoring). For details on login setup, please refer to **5.7.3 Configuring user Login** (p. 82).

### 4.1 Logging in

Login is carried out according to user classification settings.

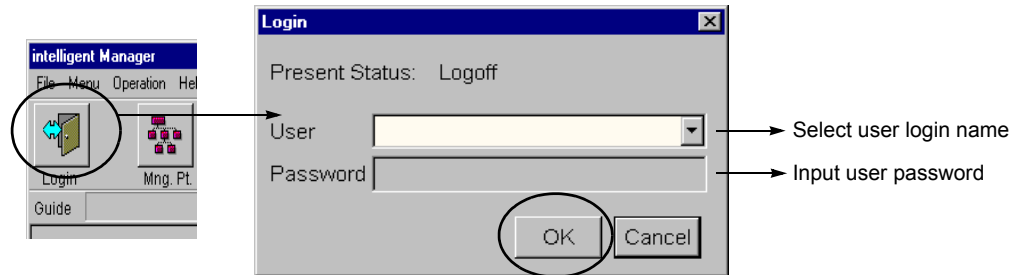

Click on the **Login/out** menu button to display the login dialog box.

Select a login name and enter password

Click on **OK** button to log in.



(if the password is incorrect, a message box is displayed).

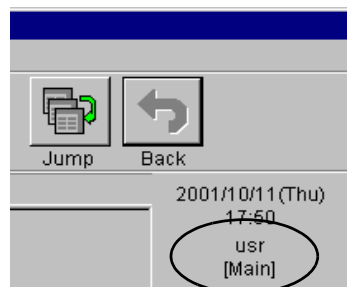

### 4.2 Logging Out

Logs out from login status.

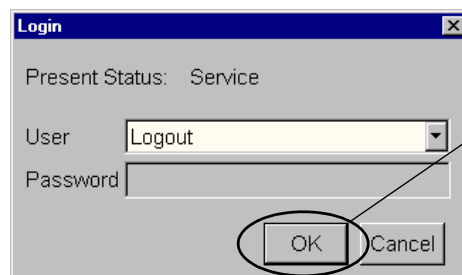

While logged in, click on **Logout** button of the menu button. A dialog box will appear as shown in the above figure.

Click on **OK** button to log out.



## 5. Operation details

### 5.1 Management Groups

- A management group is a group of management points collected together for ease of management.
- A management group is able to collect together both management groups and management points, thereby making it possible to constitute multi-layered management groups.
- A single management point may belong to more than one management group.
- You are able to create new management groups at will and modify them. Please refer to **5.7.1 Configuring Management Groups** (p. 75).
- A management group is only able to manage collective layers of management points and cannot be used for individual monitoring and operating.

Click the **Management Points** button from the menu buttons.

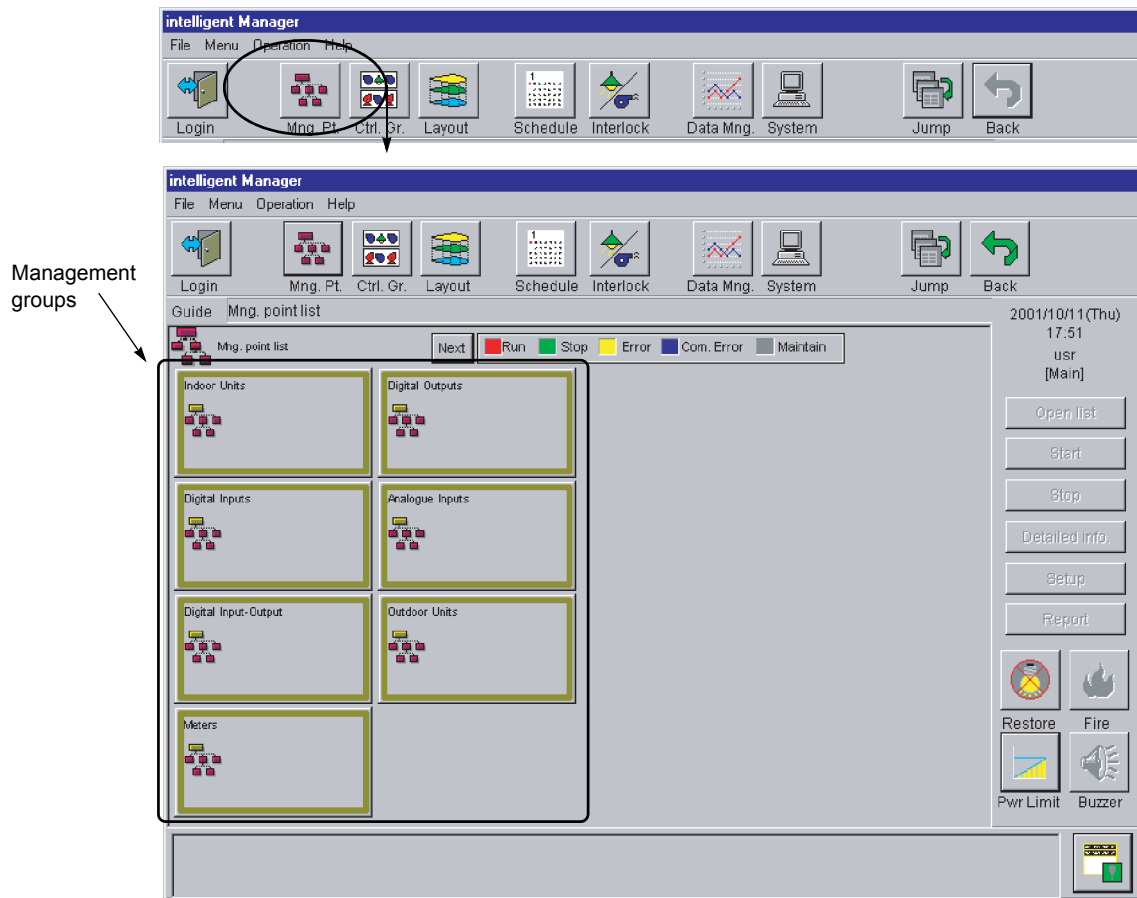

#### 5.1.1 State Monitoring List

The state of management points (Start/Stop, Malfunction) may be understood from the list displayed.

As the monitoring of equipment is not displayed in the group, to access it click the button corresponding to the group to be checked.

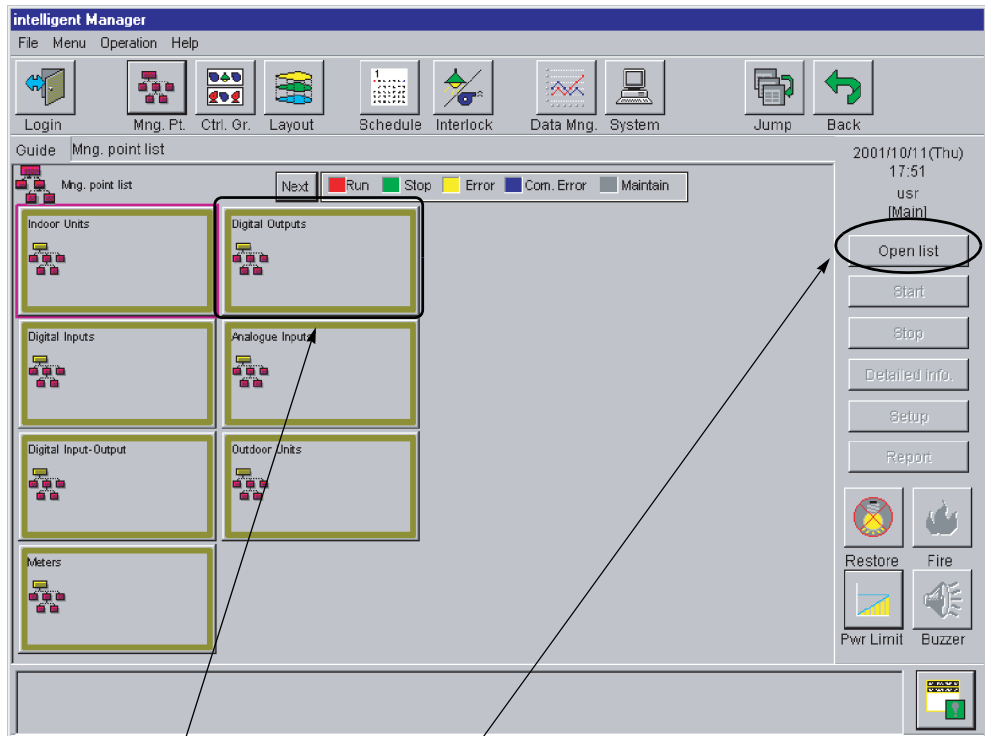

Click the group button to enable the **Open list** button. Then click the **Open list** button to display the list within the group.

The management groups will appear listed as shown in the above screen. Click once more on the sub-group and **Open list** buttons.

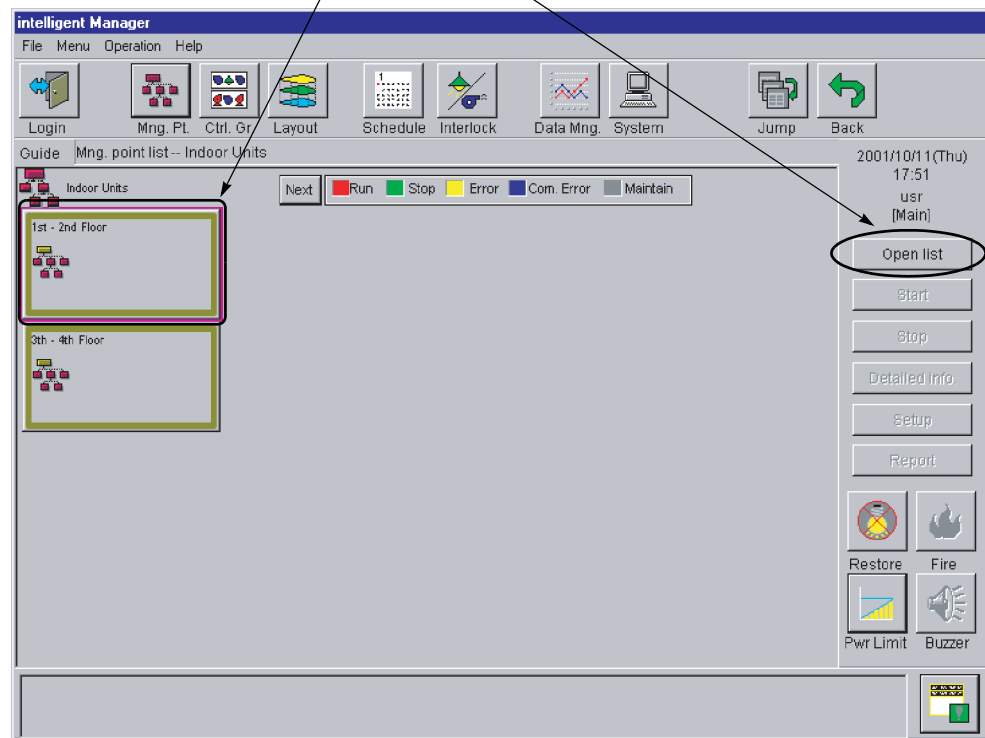

The management groups and management points will appear listed as displayed in the above screen. This shows how both management points and management groups can be collected within a management group. Henceforth the list within a management group may be displayed and opened in the same way.

The points of the group list are displayed.

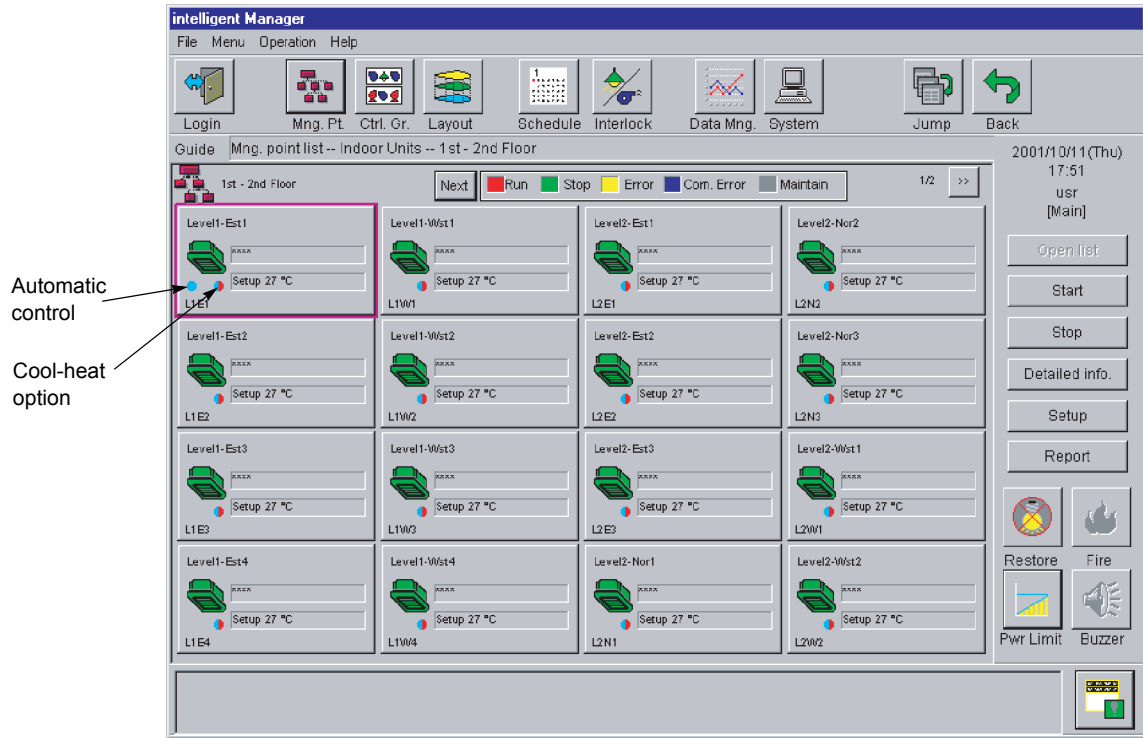

The state of a management point is shown by the color of its icon.

- Red:** Running
- Green:** Stop
- Green blinking:** Emergency stop
- Yellow blinking:** Malfunction
- Blue:** Communication error
- Gray:** Under maintenance

The marks for the filter sign, cooling/heating options and automatic control (interlocking and scheduling) are also displayed.

**Note** An asterisk (\*) after the operation mode indicates that the system is in defrost state. Icon color Red and Green can be switched.

**State Monitoring (legend)**

The state of a management point is shown by the color of its icon.

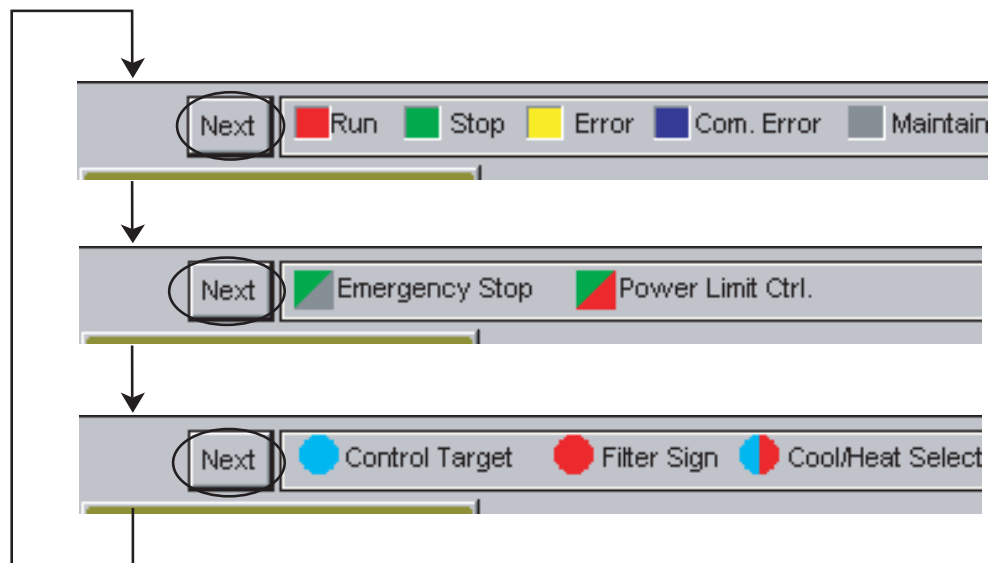
**Legend**

Click the **Next** button to display the legend corresponding to the upper and lower parts of the icon respectively.

**The marker to the lower right of the main icon**

Blue/red: Management point with cooling/heating option

Red: Filter sign

Blue: Under automatic control (Management points connected with Interlocking and Scheduling)>

**Changes in Icon State**

Changes in icon state - Start/Stop/Malfunction - are displayed as follows:

**Equipment Malfunction:Indicates abnormal state of air-conditioner or equipment**

Monitoring Error:      Inconsistency error  
                                  Abnormal Start/Stop failure  
                                  Abnormal Maximum/Minimum limits  
                                  Abnormal duration of continuous operation

Communication error: Communication error state of DIII-Net  
                                  Communication error state of Sequencer

Under maintenance: Indicates that equipment is under maintenance

Emergency stop:        Indicates control state of emergency stop

The icons indicating the control group display the representative states of management points belonging to the control group in descending order of priority.

Priority: Stop < Running < Communication Error < Equipment Malfunction (Monitoring Error) < Under maintenance

### 5.1.2 Start/Stop Operation

Start/Stop operation can be performed only on management points for which there is a Start/Stop/Setting authority. Please refer to 5.7.3 Configuring user Login (p. 82).

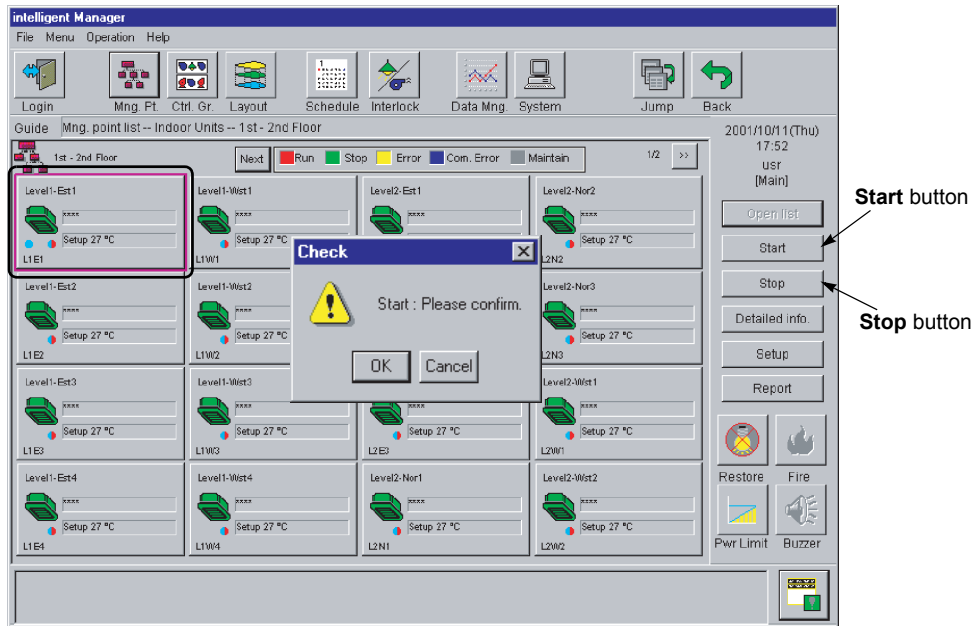

First select the management point to be started up.

Then click on the cell of a management point.

If the management point has Start/Stop capability, the **Start** and **Stop** buttons will be enabled.

Click the **Start** button to display the confirmation dialog box.

Click **OK** to start the operation or **Cancel** to cancel.

Similarly, if the **Stop** button is clicked, the confirmation dialog box will be displayed.

Click **OK** to stop the operation and **Cancel** to cancel.

If a management point without startup capability is selected, the **Start** and **Stop** buttons will gray out (that is, clicking has no effect on them), and Start/Stop operation cannot be performed.

### 5.1.3 Displaying detailed Information

This displays detailed information on management points.

To check detailed information, click on the management point you wish to check, followed by a click on **Detailed Information**.

In the example below, click on the cell of a management point, followed by a click on the **Detailed Info** button.

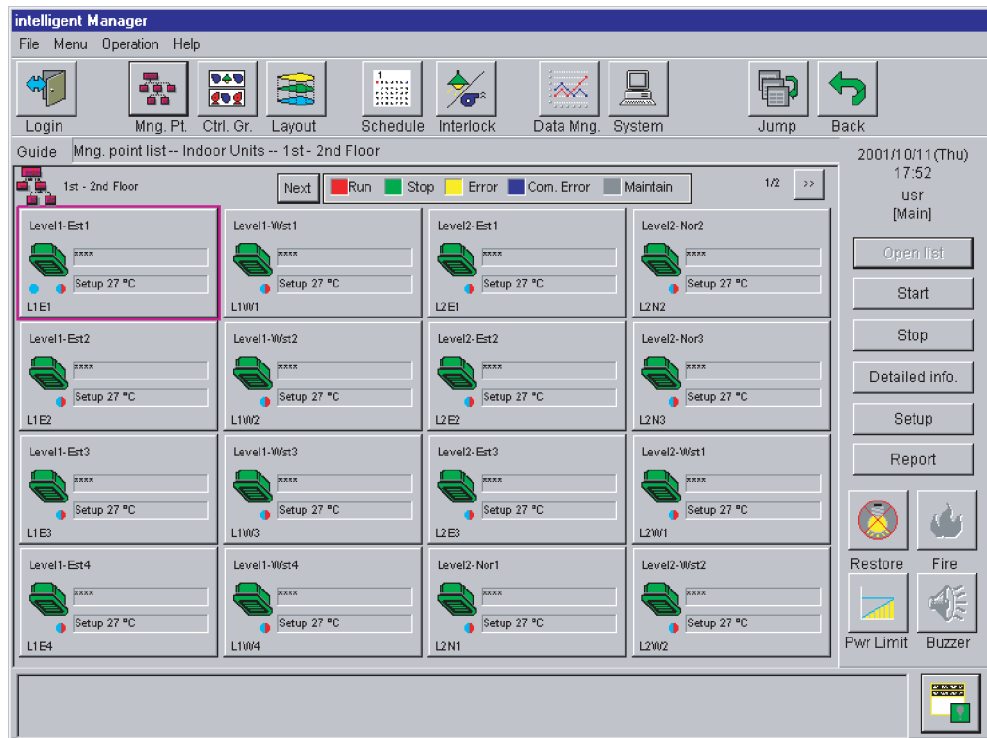

The detailed information dialog box will appear.

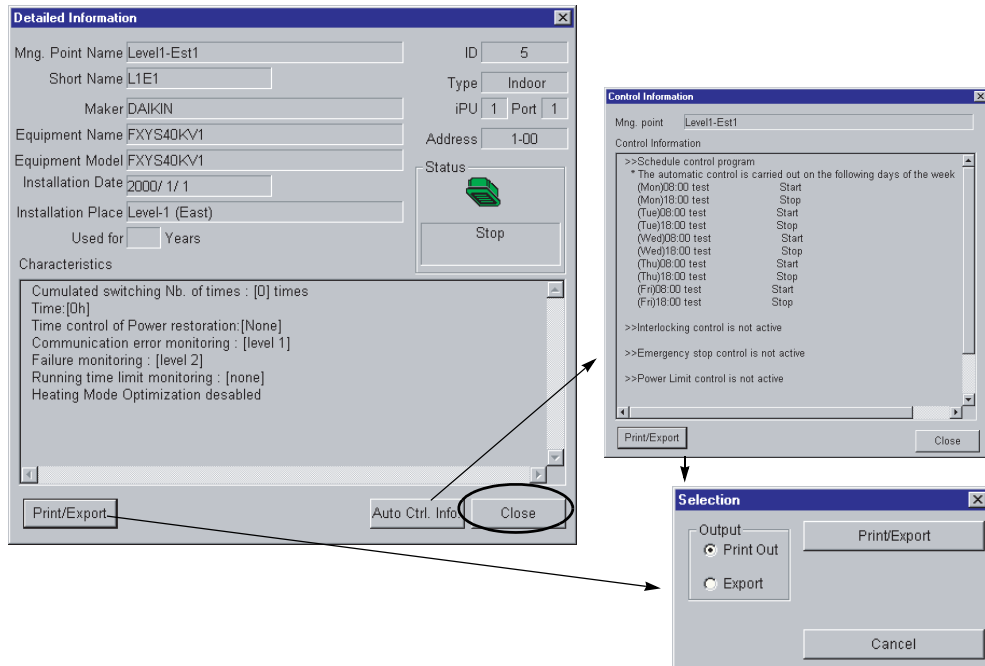

Click on the **Print/Export** button to print the detailed information on the system printer or to save them in a CSV (comma separated) format file.

Click on the **Auto Ctrl. Info** button to display the dialogue with information of this management point related with automatic control programs (schedules, interlocking). Click on the **Print/Export** button of this dialogue to print the automatic control information on the system printer or to save them in a CSV (comma separated) format file.

To close the dialog box, click on the **Close** button.

#### 5.1.4 Setting up equipment

Various setups can be performed only on management points for which there is a Start/Stop/Setup authority. Refer to **5.7.3 Configuring user Login** (p. 82).

First select the management point whose setup you wish to modify.

Click on the **Setup** button to display the setup dialog box.

The items that may be set up will vary according to the management points.

5.1.4.1 In the case of Daikin Air-conditioner (DIII Air-conditioner)

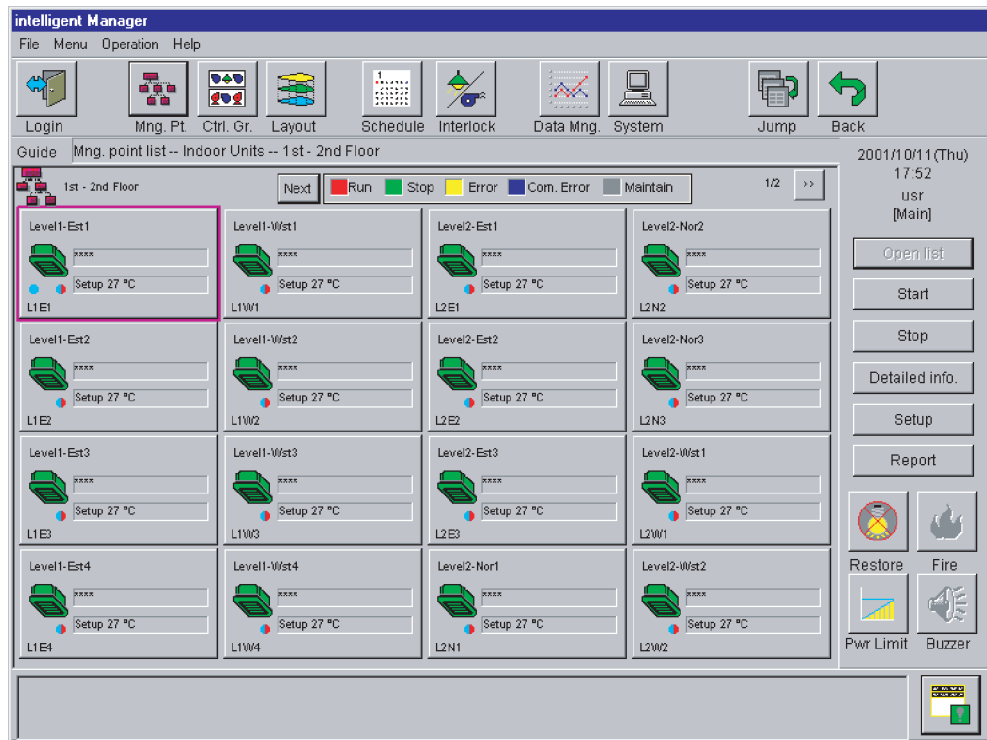

An air-conditioner setup dialog box is displayed.



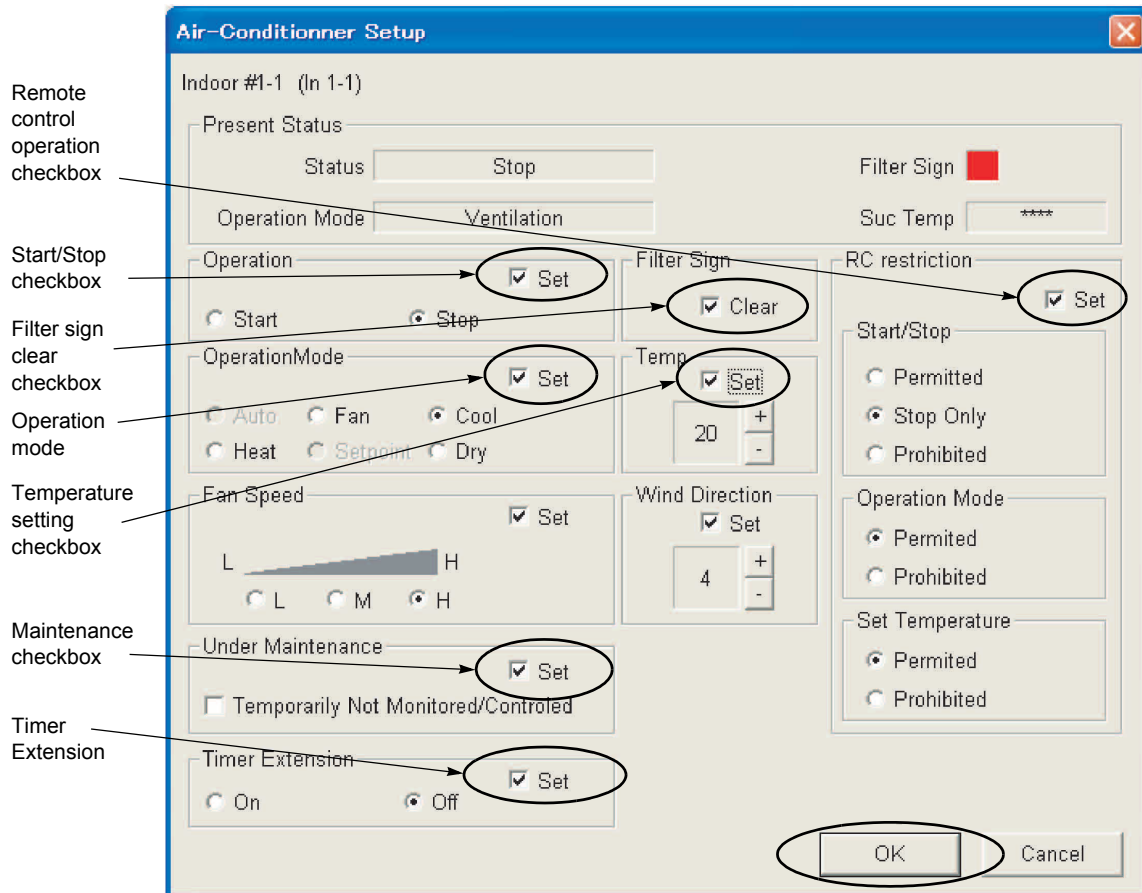

**Note** An asterisk (\*) after the operation mode indicates that the system is in defrost state.

**The following setup is then possible.**

The items that may be set up will vary according to air-conditioner compatibility.

- *Start/Stop*  
If the **Setup** check box has been checked, **Start** and **Stop** will be enabled and can therefore be selected. The same setup can be performed as in **5.1.2 Start/Stop Operation** (p. 16).
- *Operation Mode Setup*  
Check the **Setup** check box to enable the modes to be set up. Select the desired Operation Mode.  
\* If the operation mode is set to "Dry", any indoor unit with no cooling/heating selection right for the same refrigerant system will not change to the "Dry" mode except in the cooling mode.
- *Fan Speed and Direction Setup*  
Check the **Setup** check box to enable the fan speed and direction options. Select the desired intensity and direction of airflow.

- *Timer Extension*

Check the **Timer Extension** check box to display the setup items of 2 hours limitation control operation (this indoor unit will be stopped automatically 2 hours after start). Select Timer Extension On / Off.

- *Clear Filter Sign*

If the filter sign appears, the **Clear** check box will be automatically enabled. Check this box to clear the filter.

- *Temperature Setup*

For temperature setup, the **Setup** check box is enabled only when the Operation mode check box has been checked and the temperature setup mode has been enabled.

In this case, if the check box has been checked, temperature setup and the **+** and **-** buttons are enabled.

Click these buttons to modify the temperature setup.

The possible setup range is limited by the operation mode.

- *Remote-control Operation*

Check the **Setup** check box to display the setup items of remote-control operation. Select Permission/Prohibition for each of these items.

- *Under maintenance*

Check the **Setup** check box to enable the **Temporarily Out of Monitoring/Control** check box. By checking this check box, the management point in question is set up/ released from under maintenance.

*When the management point is under maintenance*

All monitoring and control pertaining to a management point under maintenance are disabled.

Under maintenance appears on the monitoring screen.

Only the Setup/Release of the check mode remains in the history. (Changes of state while under maintenance etc. are not recorded).

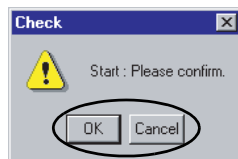

Click the **OK** button to display a confirmation dialog box once all setups have been modified.

Click **OK** to carry out modifications to the setup or **Cancel** to cancel.

5.1.4.2 HRV

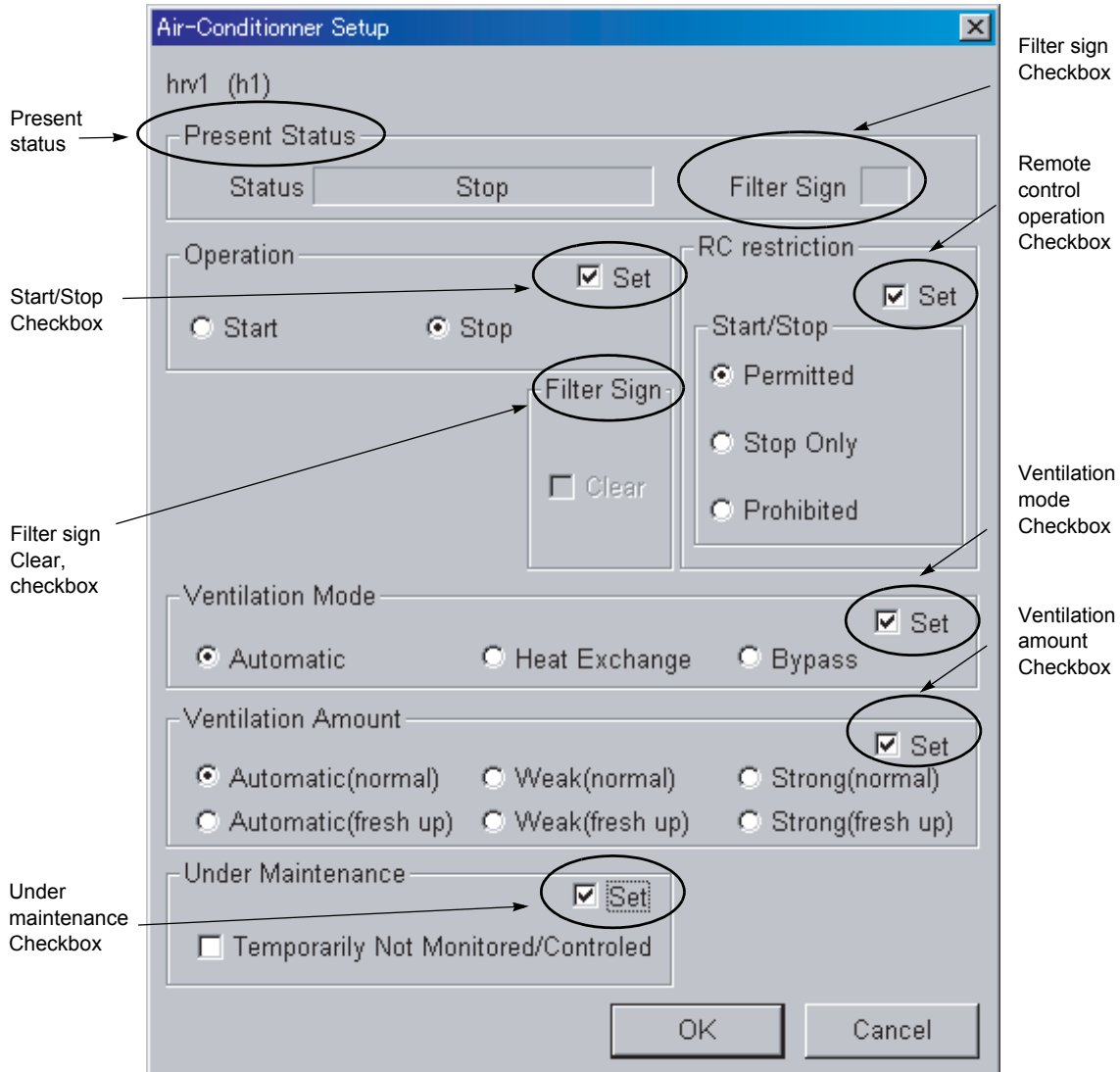

Setting is available as follows.

Setup of HRV is shown below

- **Present status**  
Displays whether the unit is operating or is stopped now.
- **Filter sign**  
Displayed in red when filter sign appears.
- **Start/Stop**  
Place a check in setup of checkbox to choose start or stop.
- **Filter sign clear**  
When a filter sign appears, checkbox of clearing is displayed automatically. Check the checkbox of clearing.

- *Remote controller operation*

Check the setup of checkbox to enable setting of remote controller operation. Start/Stop allows setting of Permit/Prohibit and Stop only.

- *Ventilation mode*

Check the setup of checkbox to enable setting of ventilation mode. Automatic, total heat exchanger, and bypass are available for selecting.

- *Ventilation amount*

Check the setup of checkbox to enable setting of ventilation mode. Automatic, weak, and strong (normal and fresh-up) are available for selecting.

- *Under maintenance*

Check the **Setup** check box to enable the **Temporarily Out of Monitoring/Control** check box. By checking this check box, the management point in question is set up/released from under maintenance.

---

*When the management point is under maintenance*

All monitoring and control pertaining to a management point under maintenance are disabled.

Under maintenance appears on the monitoring screen.

Only the Setup/Release of the check mode remains in the history. (Changes of state while under maintenance etc. are not recorded).

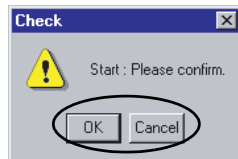

Click the **OK** button to display a confirmation dialog box once all setups have been modified.

Click **OK** to carry out modifications to the setup or **Cancel** to cancel.

---

5.1.4.3 For equipment with Start/Stop capability

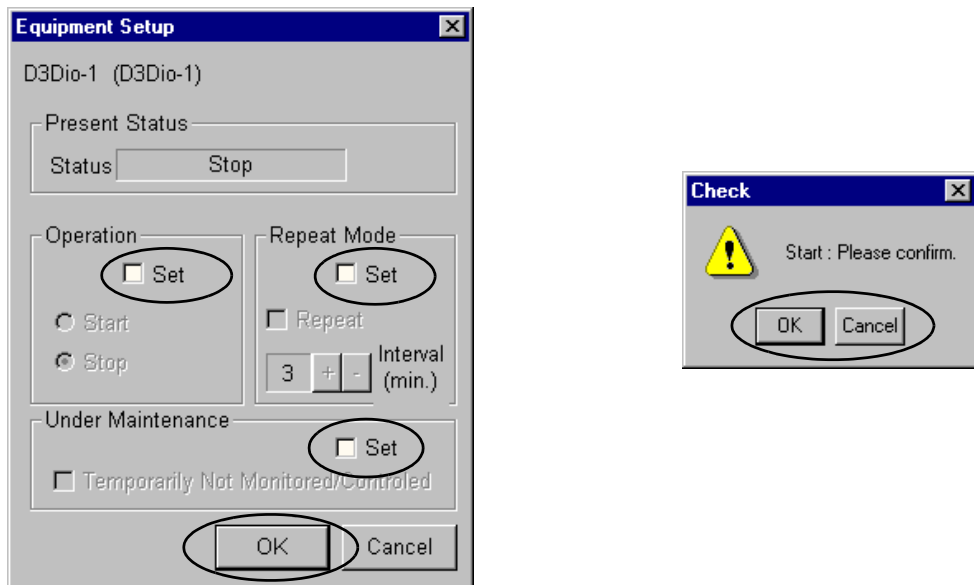

The following setups are possible in this case.

- *Start/Stop*

Check the **Setup** check box to enable **Start** and **Stop**. They can then be selected.

- *Repeat Mode*

Check the 'Set' check box to enable the **Repeat** checkbox. When the **Repeat** checkbox is checked, the time interval and + and - buttons are enabled.

The repeated time interval can then be altered by means of these buttons.

Start/Stop instructions are given within a fixed interval (specific value) so that the Start/Stop state of the equipment can be executed as indicated, regardless of manual operation etc.

- *Under maintenance*

Check the **Setup** check box to enable the **Temporarily out of Monitoring/Control** checkbox. When this box is checked, the setup changes to 'under maintenance'.

Click the **OK** button to display a confirmation dialog box once all setups have been modified.

Click **OK** to carry out modifications to the setup or **Cancel** to cancel.

## 5.1.4.4 Ao

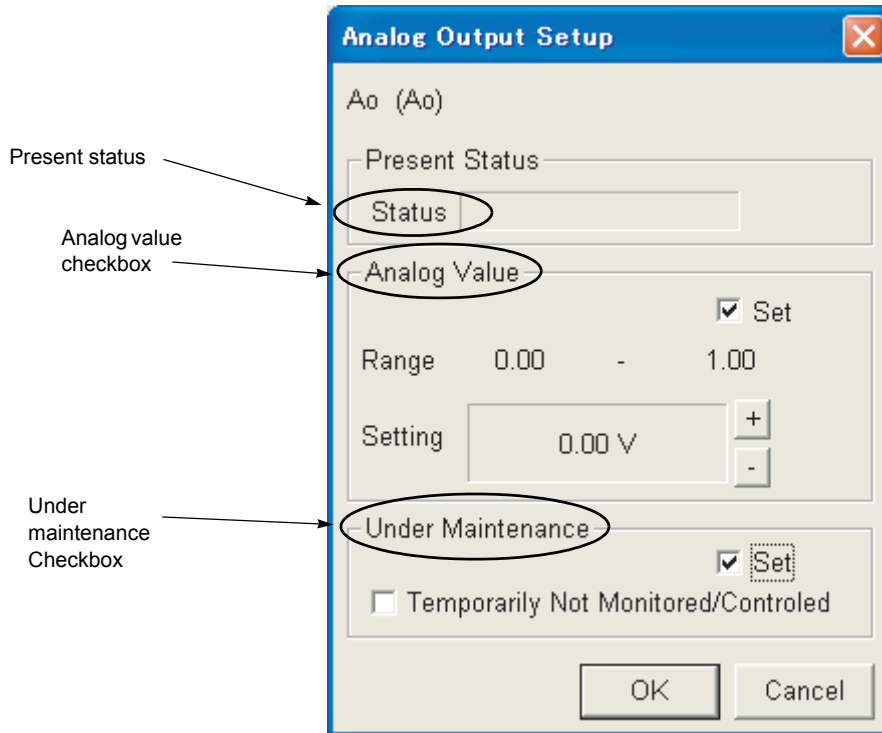

Setting is available as follows:

- *Present status*

Displays whether the unit is operating or is stopped now.

- *Analog value*

Check "setup" (Set) of checkbox, then the button "+" and "-" are displayed. Press "+" and "-" to set an analog value.

- *Under maintenance*

Check the **Setup** check box to enable the **Temporarily out of Monitoring/Control** checkbox. When this box is checked, the setup changes to 'under maintenance'.

Click the **OK** button to display a confirmation dialog box once all setups have been modified.

Click **OK** to carry out modifications to the setup or **Cancel** to cancel.

## 5.1.4.5 For other equipment

When setting up, check the **Setup** checkbox to display the items, which may be set up.

In this case setup is only possible when **under maintenance**.

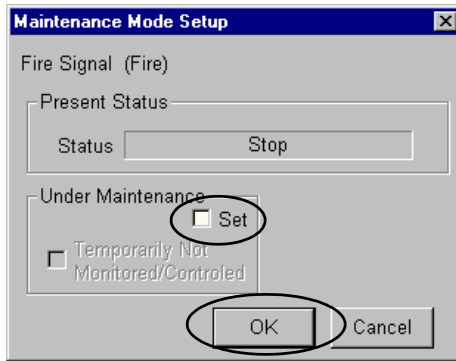

**Under maintenance**

Check the **Setup** check box to enable the **Temporarily out of Monitoring/Control** checkbox. When this box is checked, the setup changes to **under maintenance**.

**5.1.5 Table view Function**

This gives a list of statistical information about the management points on display. Click the **Report** button.

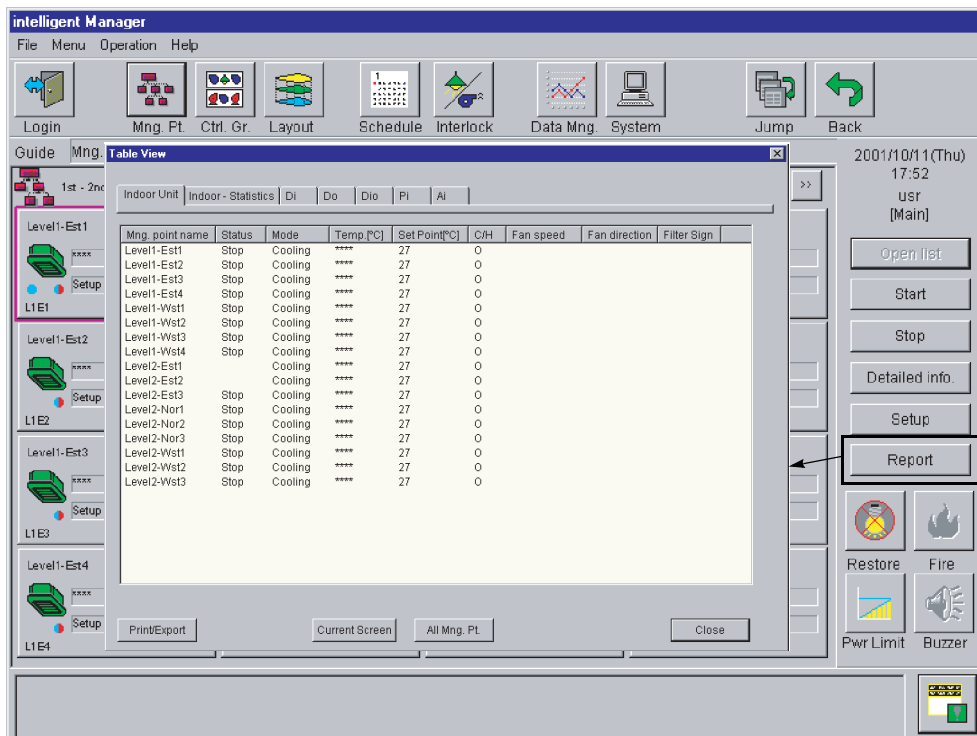

The Table View dialog box is displayed.

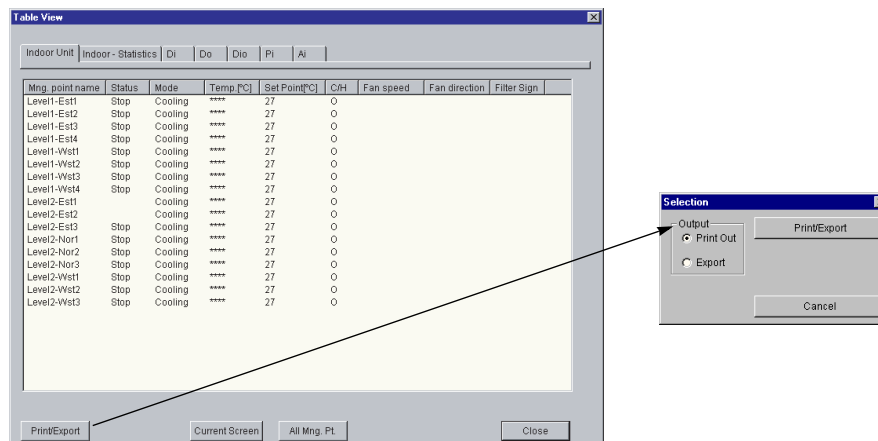

Click on the **Print/Export** button to print the detailed information on the system printer or to save them in a CSV (comma separated) format file.

The meaning of each item is shown below:

- Mng. point name : Name of management point
- Status : Status of management point
- Mode : Operation mode of management point
- Temp. [°C] : Suction temperature at the management point (When it is invalid or indefinite, "\*\*\*\*" is displayed.)
- Set Point [°C] : Set temperature at the management point (When it is invalid or indefinite, "\*\*\*\*" is displayed.)
- C/H : When this management point is a cool/heat master, "0" is displayed.
- Fan Speed : Wind volume at the management point (1 - 3 or empty when it is invalid or indefinite.)
- Fan Direction : Wind direction at the management point (0 - 6, Swing or empty when it is invalid or indefinite.)
- Filter Sign : When filter sign is on, "\*" is displayed.
- Timer Extension : Timer extension setting status "ON/OFF" is displayed.
- Switch Nb. : Accumulated number of Start/Stop (the number of times where the unit changed from stop to start)
- Warning Nb. : Upper limit of the number of Start/Stop
- Ratio [%] : Switch Nb. / Warning Nb. x 100
- Operating Time [h] : Accumulated operating time
- Warning Time [h] : Upper limit of operating time
- Ratio [%] : Operation time (h) / Warning time (h) x 100
- Pulse Value : Pulse value of management point
- Used Amount : Use quantity
- Value : Analogue value
- Unit : Preset unit character

---

**Note** An asterisk (\*) after the operation mode indicates that the system is in defrost state.

---



## 5.2 Control Groups

- A control group is a group of management points brought together for collective control.
- In a control group list, control and state display of control group units are carried out. Control and state display of individual management point units is possible in a lower layer screen.

As the operation method is identical to that of management point lists, please refer to **5.1 Management Groups** (p. 12).

- A management point may belong to more than one control group.  
This supposes that a given management point will take the appropriate form when belonging both to a normal control group and to the control group used in the case of emergency stop.

Click the **Ctrl. Gr.** button from the menu buttons.

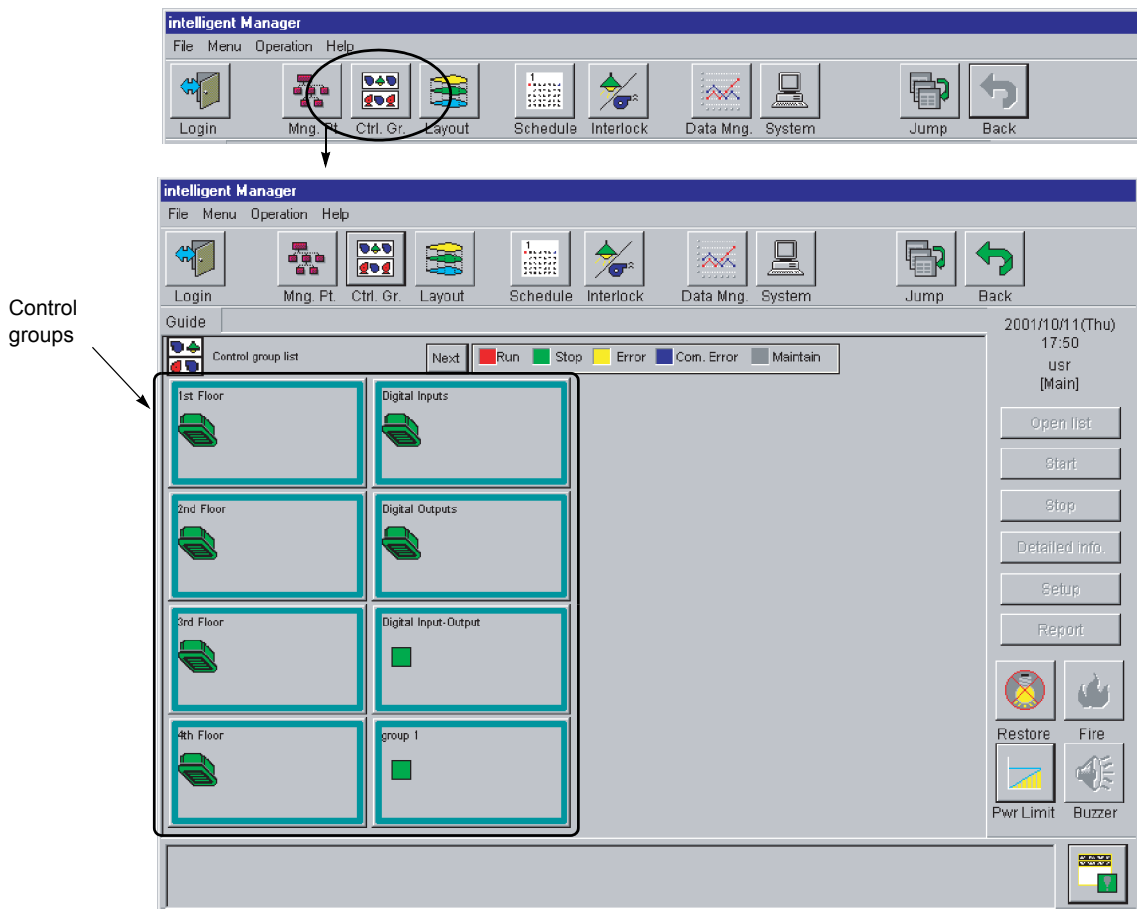

### 5.2.1 Monitoring Control Groups

It is possible to monitor the states and malfunctions of the collective control groups. Moreover, control and state display of management point units is possible in a lower layer screen.

#### Color of Control Group Icons

Priority	Color	Description
1	yellow blinking	Malfunction detected in one or more of the management points within the control group
2	blue	Communication error detected in one of more of the management points within the control group
3	red	No malfunction detected in the management points within the control group and at least one management point is operational
4	green	No malfunction detected in the management points within the control group and they have been stopped

Order of priority is 1>2>3>4.

#### Note

The attributes displayed with a control group (room temperature, etc.) are these of the top management point of the groups list.  
Icon color Red and Green can be switched.

### 5.2.2 Collectively Controlling with Control Groups

#### [Group Start/Group Stop]

Collective Start / Collective Stop operation can be performed only on control groups which contain management points for which there is a Start/Stop/Setting authority. Please refer to **5.7.3 Configuring user Login** (p. 82). Furthermore Start and Stop of individual management point are possible in a lower layer screen.

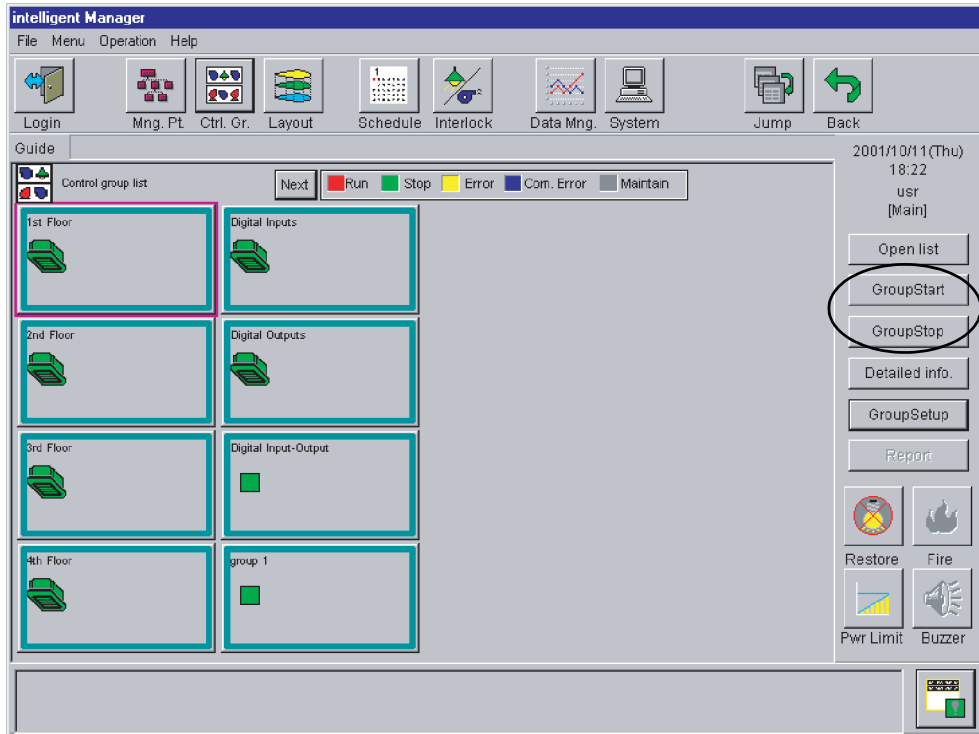

First select the control group to be started up.  
Click the button.

If the control group contains a management point with Start/Stop capability, the **GroupStart** and **GroupStop** buttons operation will be enabled.

Similarly, if the **GroupStop** button is clicked, the confirmation dialog box will be displayed.

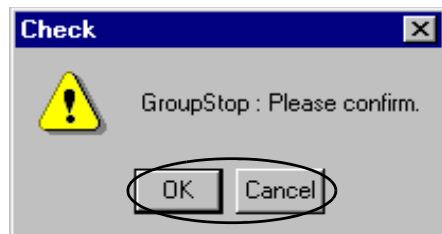
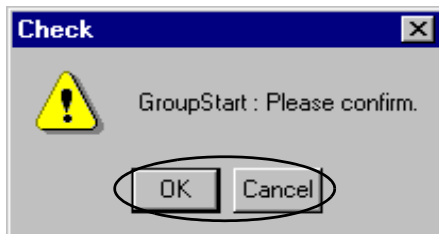

Click **OK** to stop the operation and **Cancel** to cancel.

Click the **GroupStart** button to display the confirmation dialog box.

Click **OK** to start the operation or **Cancel** to cancel.

### [Group Setup]

By carrying out a collective setup of a control group, more than one management points may be set up simultaneously.

Furthermore setup of management point units is possible in a lower layer screen.

As the operation method is identical to that of management point lists, please refer to **5.1 Management Groups** (p. 12).

First select the control group whose setup is to be modified.

Click on the **GroupSetup** button to display the setup dialog box.

The items that may be set up will vary according to the management points belonging to the control group.

If the management points in the control group belong to only one type of equipment (Daikin DIII Air-conditioner, equipment with Start/Stop capability or other equipment), the respective dialog box will be displayed in each case and setup is possible.

If there are two or more types of management points belonging to a control group, the other equipment setup dialog box will be displayed and setup will be possible only within a common range.

Therefore, in the case of Daikin DIII Air-conditioner and equipment with Start/Stop capability, it is necessary to carry out individual setups, using the management point list of the lower layer screen.

## 5.3 Visual Navigation

This function allows visual navigation through the site equipment.

### 5.3.1 Fundamentals

The system components (management points or control groups) are displayed (and dynamically refreshed) on a background image (plan or elevation view). They appear as :

- Attributes: same information as cells of a management point (operation state, room temperature, etc.)
- Icons: same icon as in cell of a management point or control group; in this case, the same color states and actions as corresponding cell are supported (start, stop, detailed information, setup, etc.)
- Buttons: navigation links to other Visual Navigation screen.

Main Screen

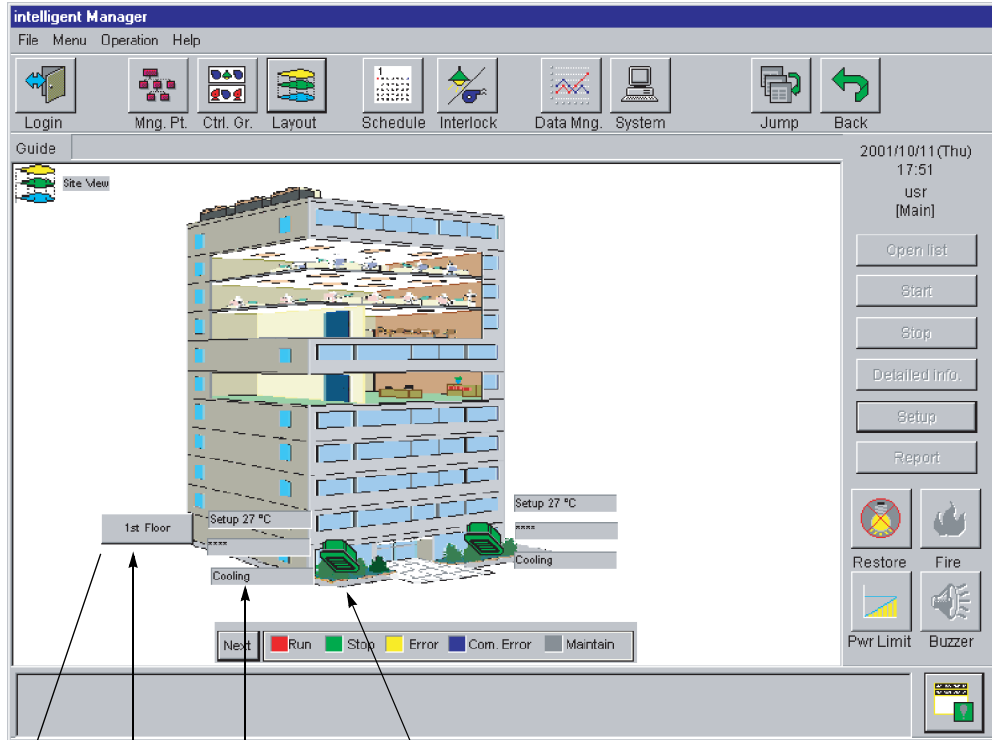

Button Information Icon

1st Floor Screen

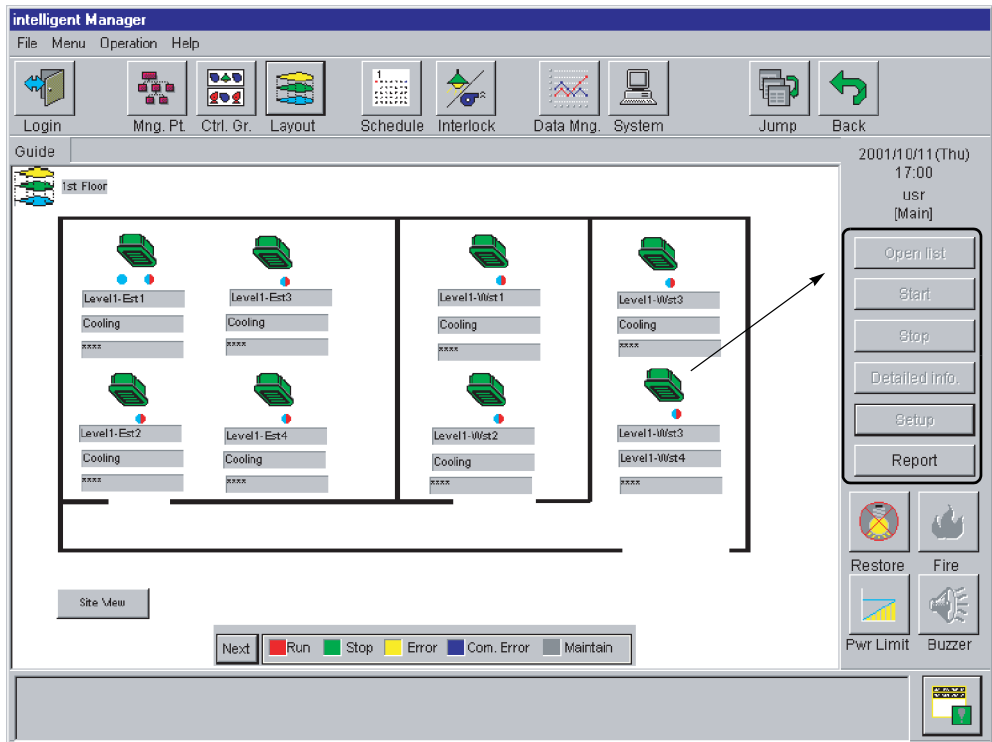

### 5.3.2 State Monitoring

This is performed by the icons and attributes.

Attributes can be of a management point only (see **5.1.1 State Monitoring List** (p. 12) and **5.1.5 Table view Function** (p. 26) for details).

Icons can be of a management point or control group.

As in management points and control groups, the colors are explained in the legend (see **5.1.1 State Monitoring List** (p. 12) and **5.2.1 Monitoring Control Groups** (p. 29) for details).

### 5.3.3 Controlling points and groups

This is performed by the icons only.

Click on an icon to select it, then operation is can be performed with the action buttons, pull-down menu or popup-menu as in management points and control groups (see **5.1.2 Start/Stop Operation** (p. 16) to **5.1.4 Setting up equipment** (p. 18) and **5.2.2 Collectively Controlling with Control Groups** (p. 30) for details)

## 5.4 Setting the Schedule

- Time schedules may be defined in advance so that control of the equipment (Start/Stop, Pre-Cool/Heat control, operation mode switchover as well as temperature setup) and permission/prohibition of remote controller can be carried out automatically.
- Schedule programs are registered in weekly blocks and the type of operation to be performed on every day of the week is specified.  
Moreover, holidays and special days over a one-year period (13 months) may be specified within the schedule program in the Yearly block. Operation method during special days and holidays may also be specified in the same way as the operational schedule of any day of the week.
- Up to 200 schedule programs may be registered. Please be careful that a higher number of schedule programs make start up procedure of the intelligent Manager system last longer.
- The appropriate authority is required to set up a schedule program.  
Please refer to **5.7.3 Configuring user Login** (p. 82). Without this authority, consultation only is possible.
- When a scheduled operation is carried out, it is reported and saved in the history record.
- Precooling/Preheating control means the air conditioner is started before the set time in order that the room temperature reach the preset temperature by the scheduled time.
- Precooling/preheating control does not work from 00:00 to 02:59.

Click the **Schedule** button from the menu buttons.

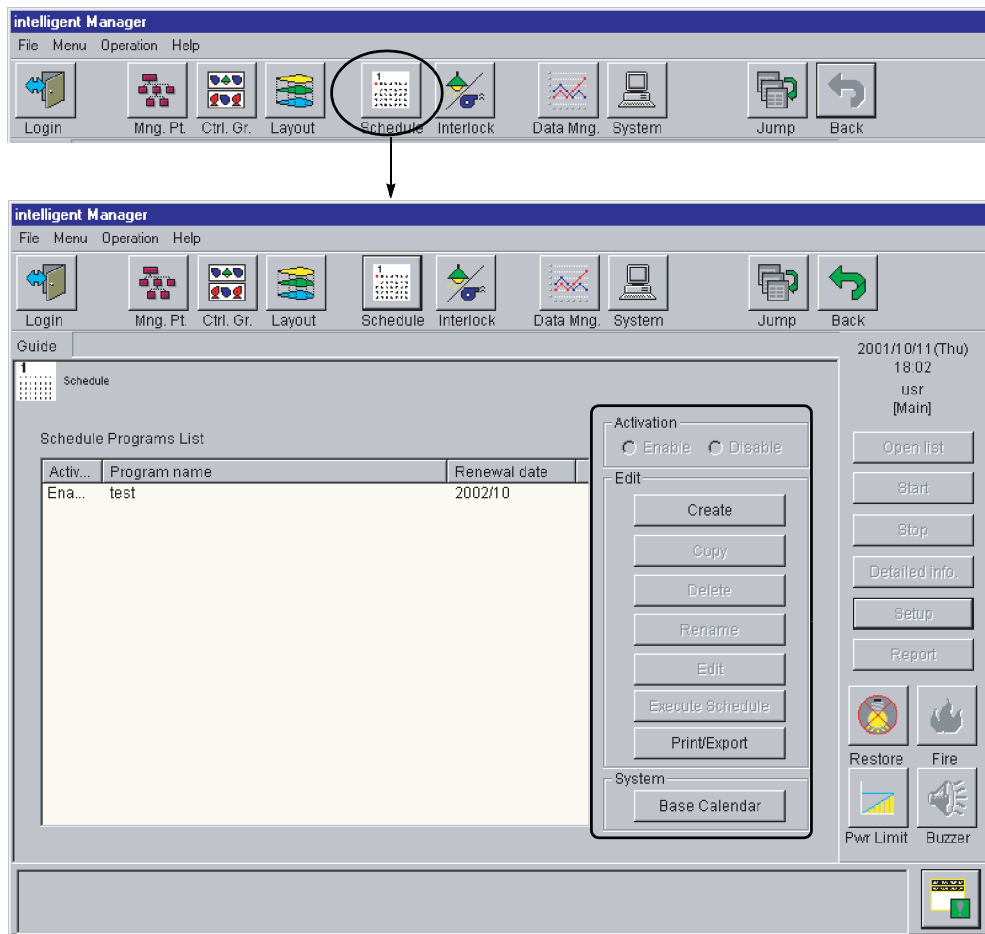

#### 5.4.1 Schedule fundamentals

A schedule **Program** is a set of time stamped actions.

These Actions are grouped in a **Weekly Schedule** organized in daily patterns (**Sunday to Saturday, Day Off and Special Day**).

These weekly schedules are repeated in a **Yearly Schedule**. The yearly calendars can be shared between programs, using the **Base Calendar** facility

As well, schedules and programs management is facilitated by editing functions (Copy, etc.).

#### 5.4.2 Managing Base Calendars

A base calendar may be given the name of your choice. The name can be a row of up to 32 characters.

Up to 6 base calendars can be created.

Click on the **Base Calendar** button to display the dialogue shown below.

Create a Base Calendar and set the limits, and the types of the days as shown below.

First decide on the range to be setup in the annual calendar.

Click the **Change** button to display the calendar setup range dialog box.

Use the **+ -** buttons to modify the range of the annual calendar and click the **OK** button to apply the desired modification.



When the range is modified, the overlapping portion before modification will be carried forward. Other months will have initial state formats. (Initial state: Only Sundays are set up as holidays).

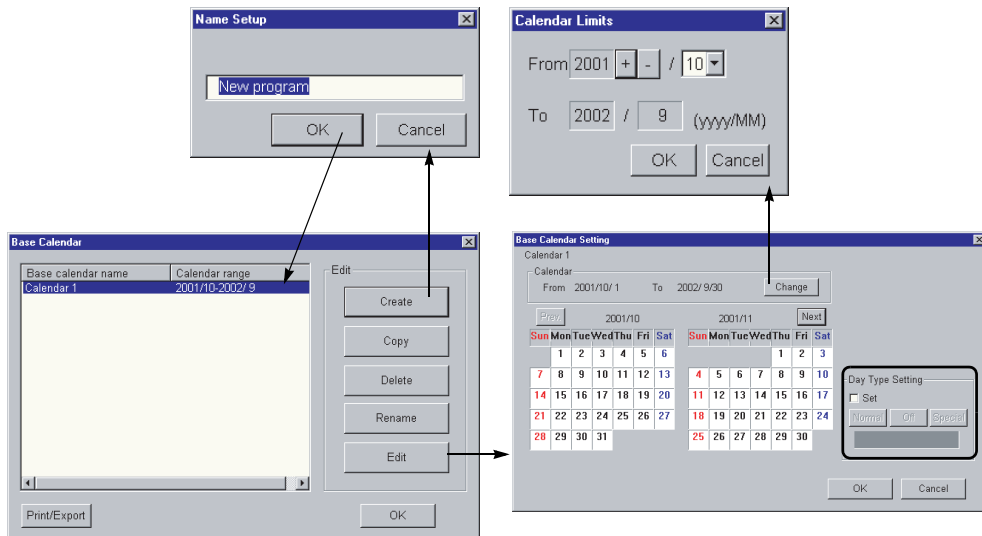

### 5.4.3 Creating a Schedule Program

A schedule program may be given the name of your choice. The name can be a row of up to 32 characters and must not overlap with other schedule programs.

Click the **Create** button to create a new schedule program. The name setup dialog box is displayed as shown below.

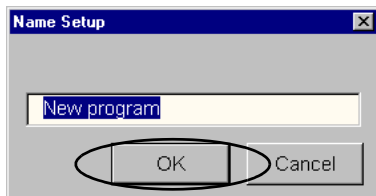

Enter the schedule name to be created onto the name setup screen. Check the contents entered for errors and then click the **OK** button

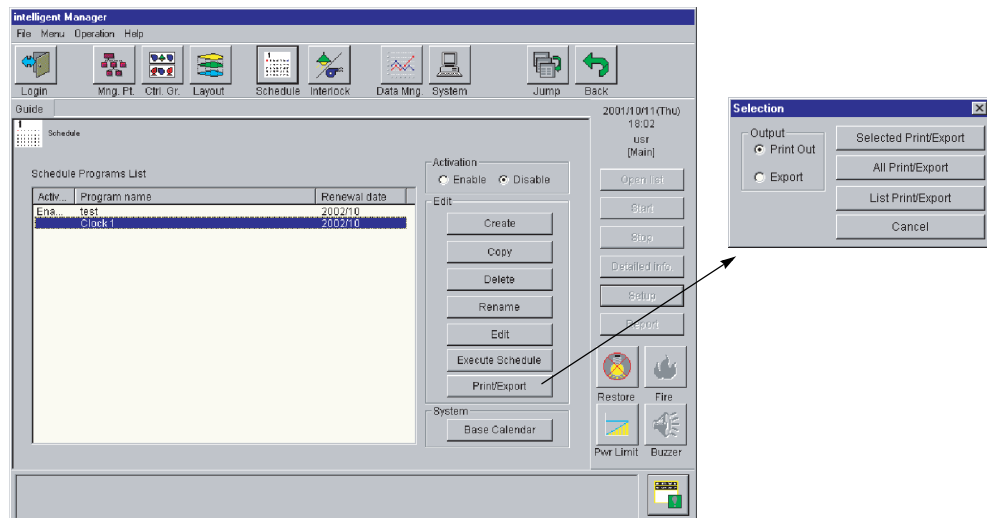

The schedule program list in the above figure shows the previously entered schedule.

Select the desired schedule to be set up on the annual calendar from the schedule list using the mouse.

Schedules (either one schedule, all schedules, or the list only) can be printed out (to the system printer) or exported into CSV (comma separated) format files.

#### 5.4.4 Annual Calendar

The annual calendar is a calendar divided into 13 months (from the first day of the starting month to the last day of the same month the following year). It can be customized with any days of your choice - such as holidays or special days.

Holiday and special day set on the calendar are discarded when corresponding month has passed, and must be updated regularly.

Warning of calendar-out is issued in the updating month (calendar limit) of prepared calendar.

To define the annual calendar, it is possible to copy it from a base calendar: click the **Calendar Copy** button and select a Base Calendar from the list (see above for Base Calendar management). Then, adjust if necessary the annual calendar by modifying its limits and the days as shown below.

Updating month of calendar is normally the final month of prepared calendar. It can also be set by pressing the modifying button.

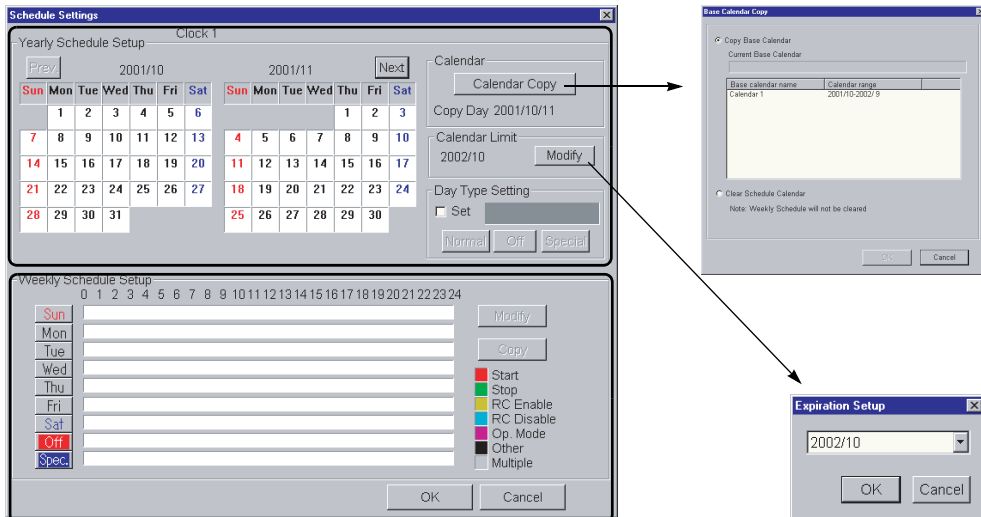

When the **Modify Limits** button is clicked, the dialog box will be displayed as above. In the screen of the above figure, the annual calendar setup is shown at the top and the weekly schedule setup below.

A 13-month setup is possible for the calendar (from the first day of the starting month to the last day of the same month the following year).

By clicking the previous month **Prev** and the next month **Next** buttons, the month before or after the month on current display will be shown.

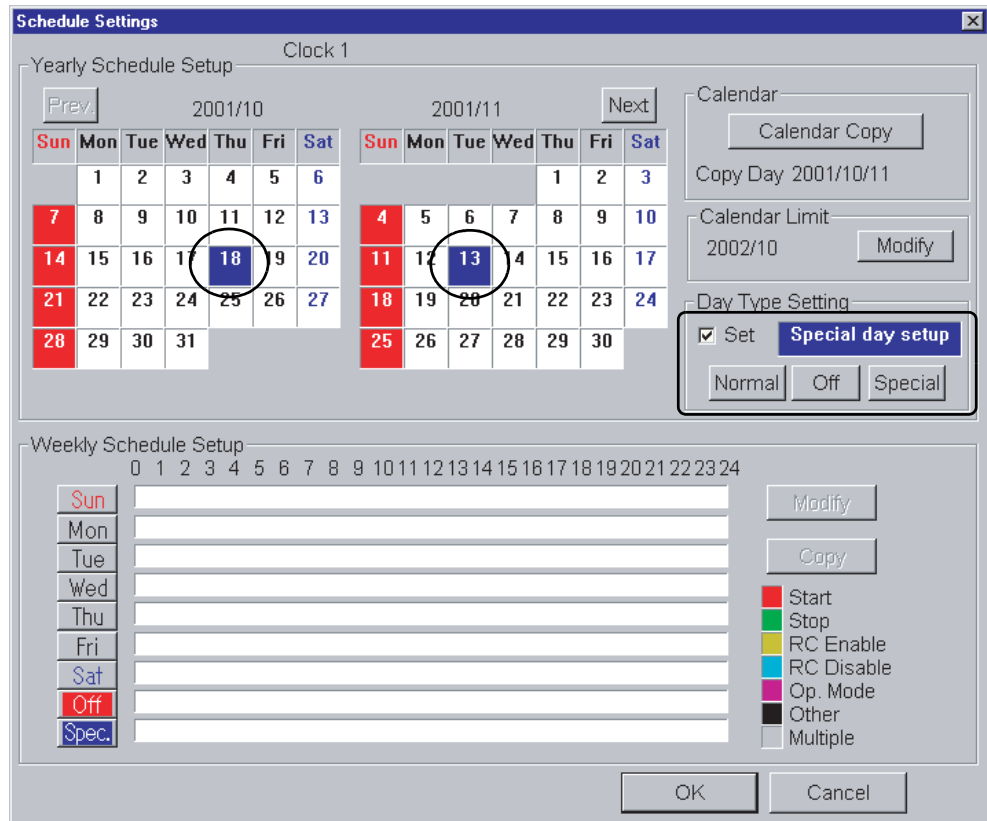

**Setting up day types**

In the initial state, Schedule set on each day of the week can be shifted. Day type setting is used when the schedule of holiday and special day is used. Click the selection buttons to modify the type of day to be set up. The selected day type will then be displayed and its color will change. White is used for weekdays, red for holidays and blue for special days. In the above figure, Holidays have been set and special days are being selected.

Click the cell containing the date to be set up to carry out the setup. In the case of the above figure, some days have been set up as holidays. As well, some days are being set up as special days. When the setup of the month on current display is completed, click the next month **Next** button to display the following month.

When the following month is displayed, set up the day type. This should be done for each of the 13 months.

**5.4.5 Weekly Schedule**

The weekly schedule indicating the type of operations to be performed during one day is specified in nine day area units: each day of the week, holidays and special days.

- *Selection to undergo control*  
The management point or control group to undergo schedule control is selected.

- *Time of Execution*

The time at which an action is executed is set up.

- *Action*

[Action] list

- Displays a list of schedule action. It is a single selecting list.

- Displayed items are as follows:

**Type:** Type of management point/control group. P: Management point, G: Control group

**Time:** Execution time of schedule action. 00:00 - 23:59

**Name:** Name of management point/control group

**Short name:** Abbreviation of management point/control group

**Start/Stop:** Start/Stop, Pre-Cool/Heat control

**R/C Mode start/stop:** Permission/Prohibition of start/stop from remote controller

**R/C Mode operation mode:** Permission/Prohibition of operation mode from remote controller

**R/C Mode Set Temp.:** Permission/Prohibition of temperature setting from remote controller

**Setpoint:** Set temperature

**Operation mode:** Operation mode

**Ventilation mode:** Ventilation mode

**Ventilation amount:** Ventilation amount

**Analog value:** Analog value

- No selection in initial condition

Please refer to **5.1.4 Setting up equipment** (p. 18) for detailed explanation of these actions.

Click the button corresponding to the day on which the schedule is to be set up (ex: **Monday**) and then click the **Modify** button as shown below.

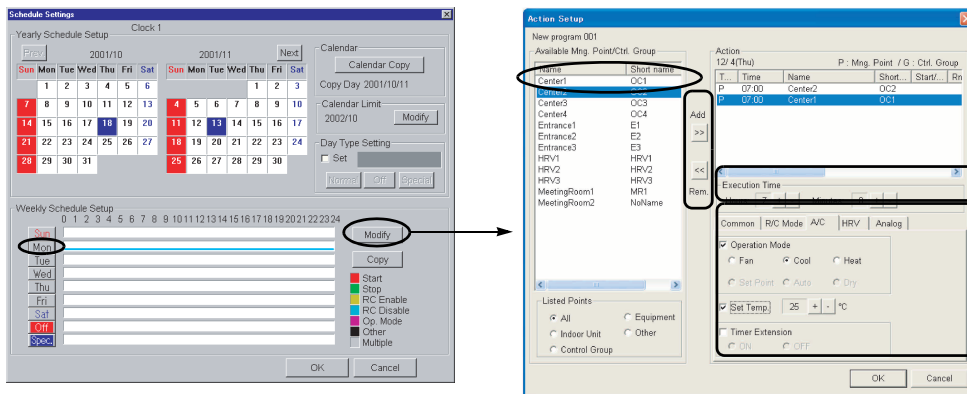

From the available management point or control group, click on the management point or control group to undergo schedule control.

Click the **Add >>** button to display the action.

Click on the added management point or control group.

Select the action to be set up and set up the execution time using the **+ -** buttons. More than one action can be set at a time.

Repeat this operation to set up the schedule for Monday.

When the schedule is completed, click the **OK** button.

Click the **Cancel** button to cancel the setup.

The schedule content is shown above. The schedule for Monday has been set up.

Repeat the same operation to set up other days.

To set up the same schedule on other days of the week, click on the day to be copied, followed by a click on the **Copy** button. A dialog box will appear. Click on the day to be copied to.

For example, click the **Tuesday** button.

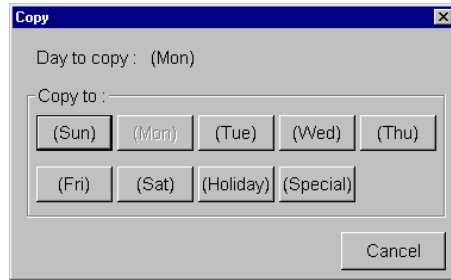

Tuesday has been set up with the same schedule as Monday.

Repeat the same operation to copy the schedule to other days of the week.

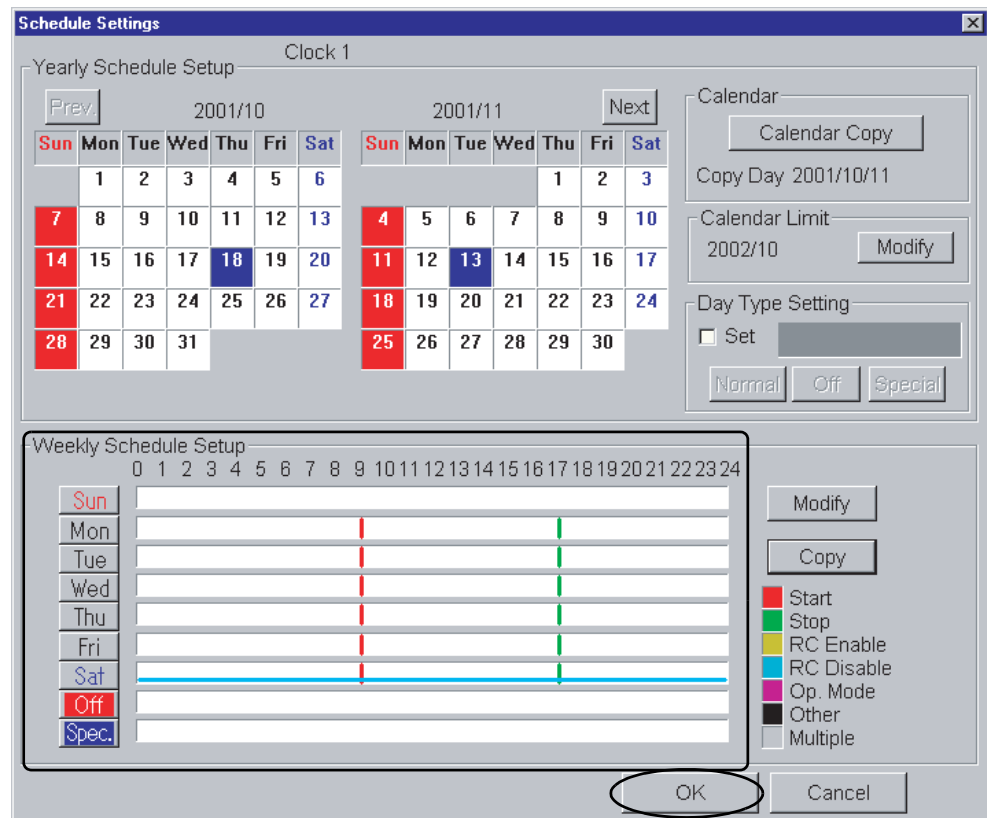

Click the **OK** button to record the setup content on completion of a schedule setup.

### 5.4.6 Executing Schedule

Actual schedule control may be checked from the dialog box as shown below. Furthermore, for temporary schedule changes at less than one week's notice, modifications may be carried out via the Executing Schedule dialog box.

Click the **Execute Schedule** button to display this dialog box.

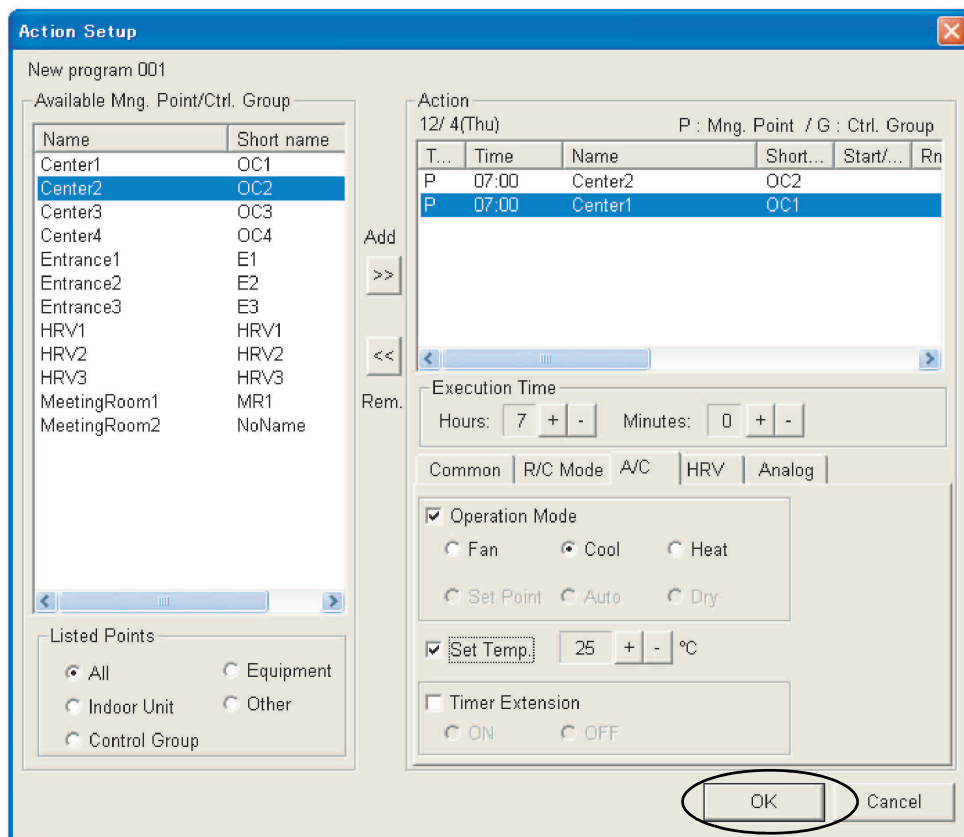
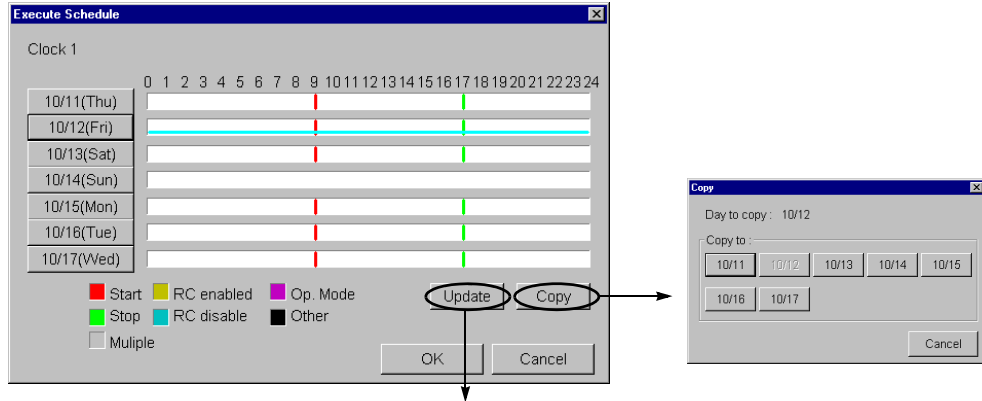

By executing schedule, based on the annual calendar and weekly schedule, the coming week's period is generated automatically. Actual schedule control is conducted according to this executing schedule.

Temporary schedule changes at less than one week's notice for the coming one-week period may be made by the execution schedule.

Click on the day whose schedule is to be modified and use the **Update** and **Copy** buttons to modify it.

### 5.4.7 Enable/Disable Instructions

Once the set-up of the annual calendar and weekly schedule has been completed, the created schedule must be enabled via the schedule setup dialog box. Furthermore, if the contents of the schedule program need to be modified, the schedule in question must first be disabled. Schedule programs may be enabled and disabled individually. When disabled, a program will not execute.

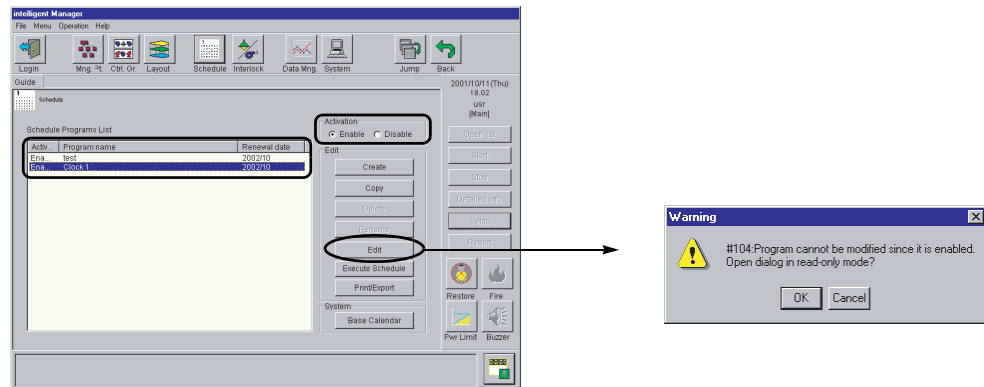

Click on the schedule program name to turn it over and it will switch over from enabled to disabled. If the schedule program is enabled, the valid mark will be displayed before its name. If it is disabled, the mark will disappear.

### 5.4.8 Copying a Schedule

An existing schedule may be copied in the following way.

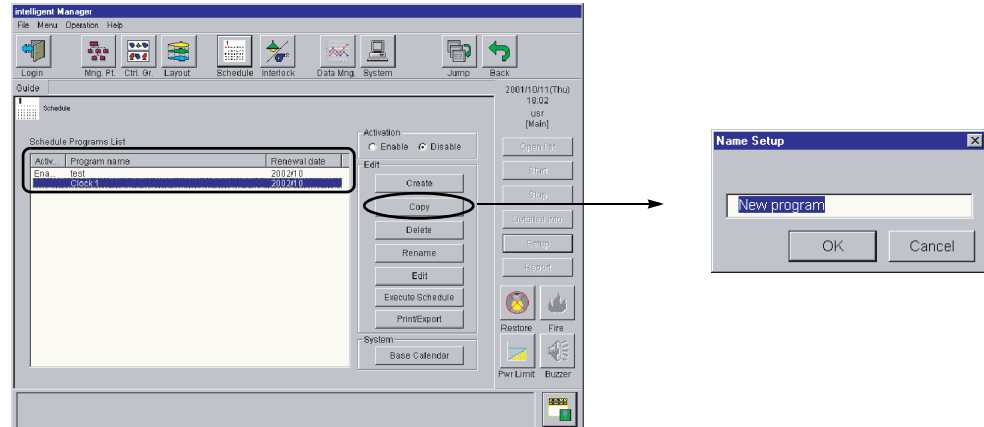

Select the name of the schedule to be copied and click the **Copy** button.



The name setup dialog box will then appear. Enter the new schedule program name and click the **OK** button.

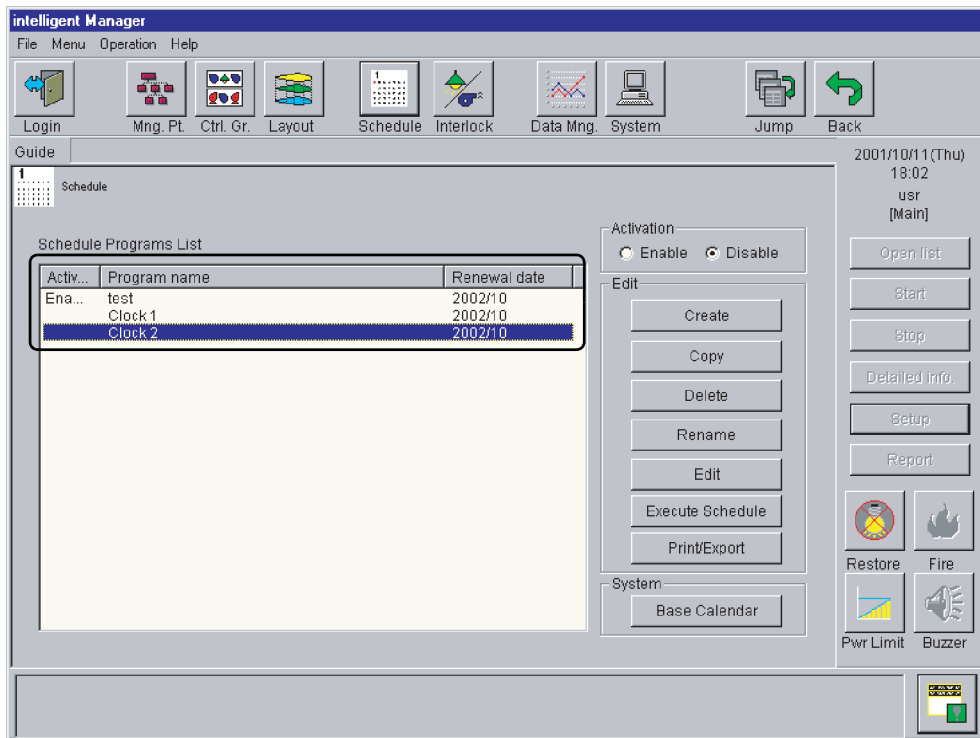

### 5.4.9 Deleting a Schedule

An existing schedule may be deleted in the following way.

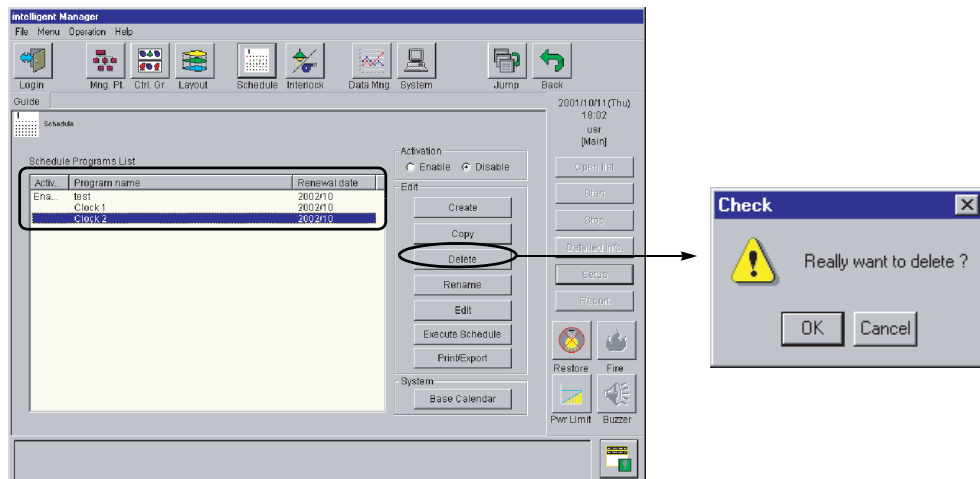

Select the schedule to be deleted and click the **Delete** button. A confirmation dialog box will then appear. Click the **OK** button to delete the schedule.

A schedule cannot be deleted when it is "enabled". First disable the schedule.

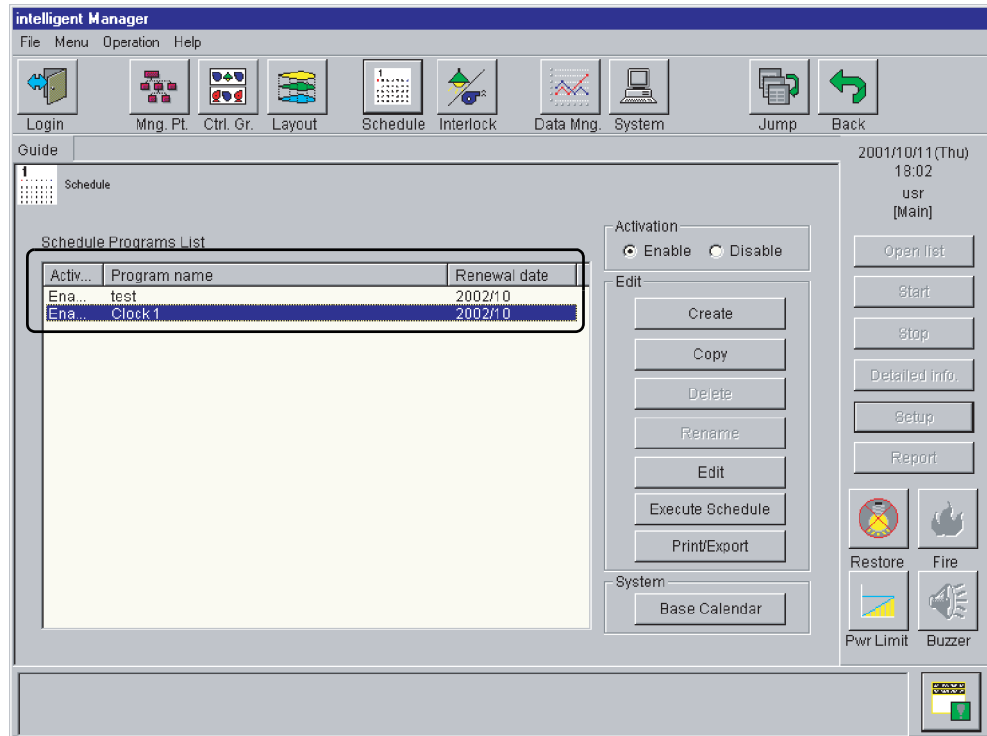

The schedule has been deleted.

#### 5.4.10 Renaming a Schedule

A schedule may be renamed in the following way.

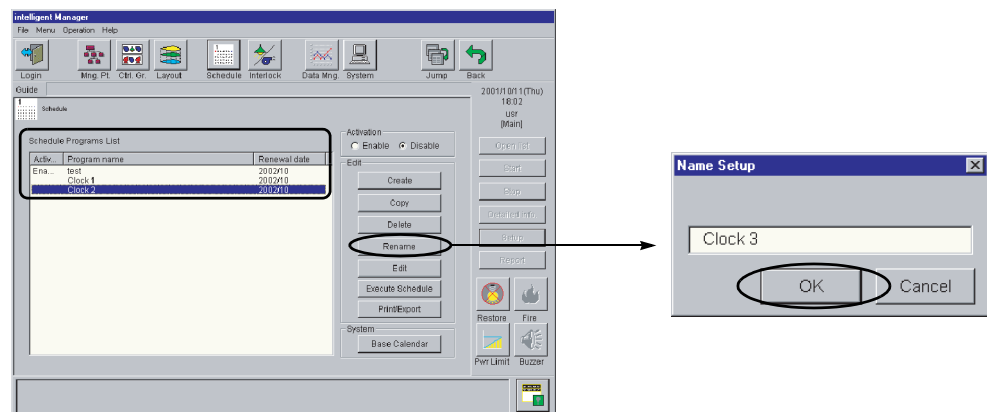

Select the schedule to be renamed and click the **Rename** button.

The name setup dialog box will then appear. Enter the new name and click the **OK** button.

**A schedule cannot be renamed when it is "enabled". First disable the schedule.**

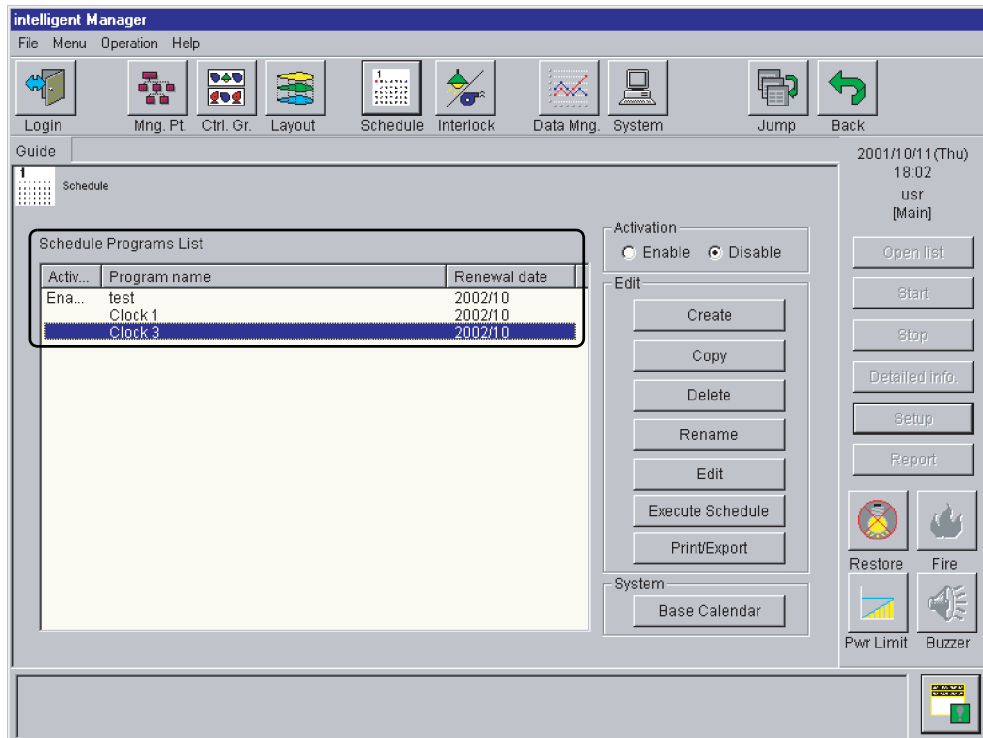

The schedule has been renamed.

## 5.5 Interlocking Function

- The interlocking function enables the cooperative action of the management points in accordance with the input conditions and output instructions defined by the interlocking program.  
When monitoring changes of state in the management points, if a change in setup state is detected in the input conditions, relevant output instructions (Start/Stop) are conveyed to the output management points.
- By means of the interlocking function, Start/Stop etc. forwarded to more than one piece of equipment - for interlocking when entering and exiting rooms, key management interlocking etc. - may be carried out.
- When interlocking control is executed, that operation is reported and registered in the history.

- The emergency stop may be set up along with the interlocking program.
- Up to 200 interlocking programs may be registered.

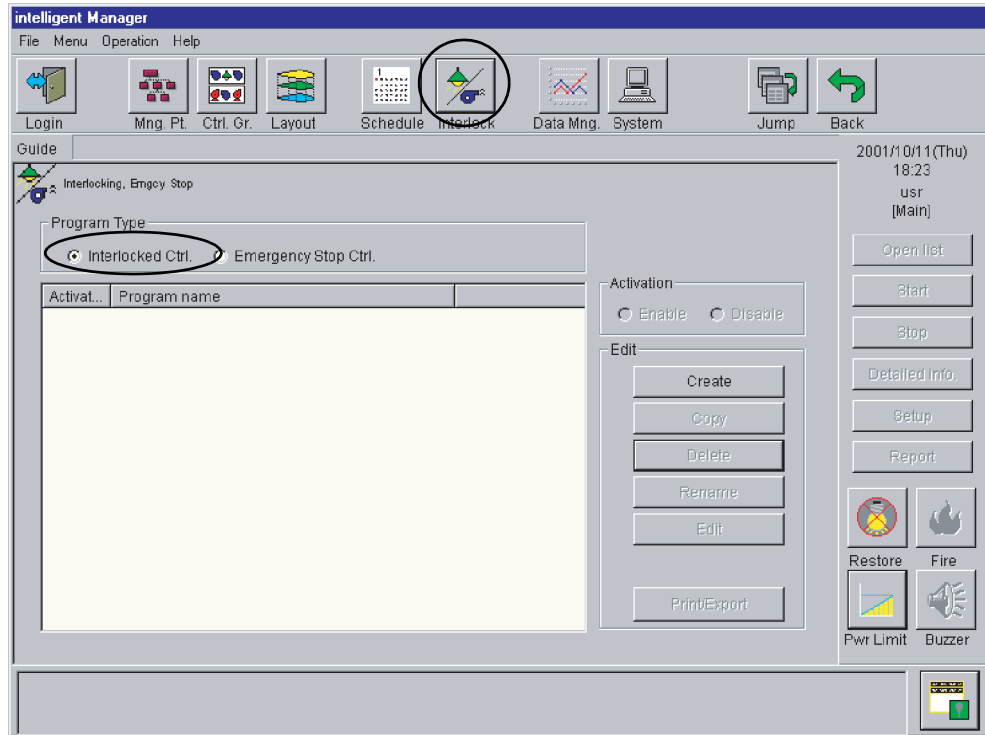

Click the **Interlocking** button from the menu buttons.  
The interlocking menu screen will appear.

### 5.5.1 Setting up an Interlocking Program

For every interlocking program, up to 128 input management points to be monitored and a maximum of 50 output items (management points or control groups) may be registered.

Select the interlocking program from the interlocking menu at the top of the screen.  
Click the **Create** button to newly register the program.

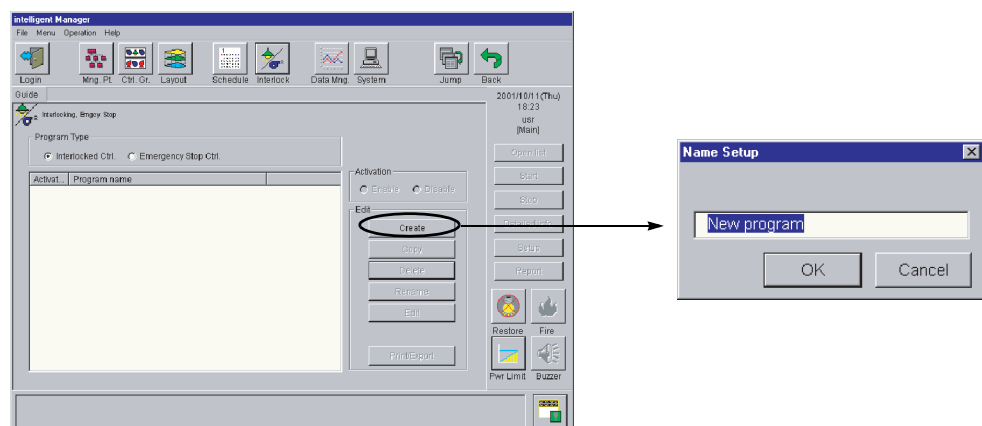

The name setup screen will appear. Enter the name and click the **OK** button. To cancel the name setup, click the **Cancel** button.

The newly registered program name is displayed on the screen.

Next set up the contents by clicking on the program name (click the scroll bar if necessary). The operation options button will be enabled on the right-hand side. Click the **Modify Program** button to display the interlocking program setup screen. An interlocking program name or contents registered previously can also be modified via the same procedure. However the program to be modified should be disabled. (Refer to next page for details of enabling/disabling switchover).

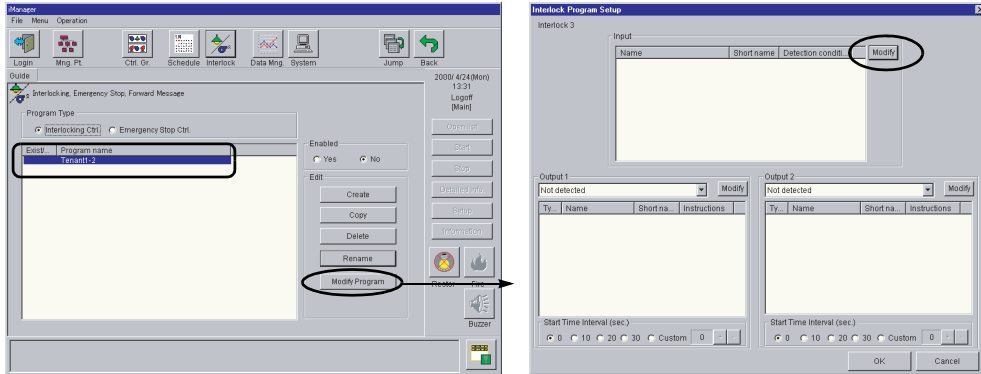

Click the **Modify** button in the Input frame.

First select the detection condition.

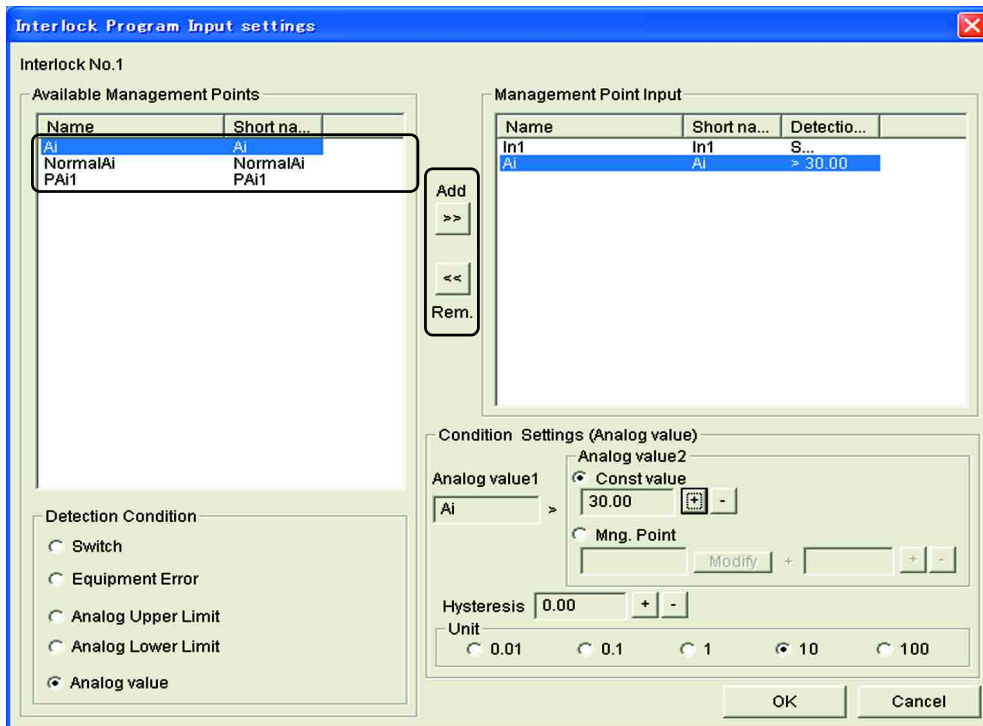

Select a management point/control group. (Click the scroll bar if necessary). When satisfactory, click the **Add >>** button. A list of the input management points registered will appear on the right.

Input management points can be removed by selecting the points to be removed from the list on the right-hand side (click the scroll bar if necessary) and clicking the **Remove <<** button.

If the setup is satisfactory, click the **OK** button. The interlocking program setup is cancelled by clicking the **Cancel** button.

The previous interlocking program setup screen (see next page) will be restored.

Five operating conditions of interlocked program are available as shown below.

- Switch (when started/stopped)
- Equipment error (when any trouble occurs)
- Analogue upper limit (when preset upper analogue limit is exceeded)
- Analogue lower limit (when preset lower analogue limit is exceeded)
- Analogue value (when preset condition formula is satisfied, where condition is judged at an interval of 1 minute.)

Output is then registered. Click the **Modify** button in the Output1 frame.

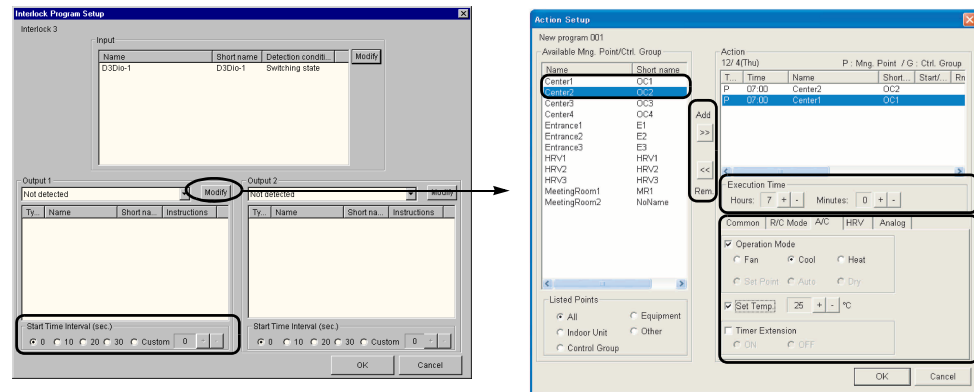

Select a management point/control group. (Click the scroll bar if necessary).

When satisfactory, click the **Add >>** button. A list of the output management points registered will appear on the right.

Select the output action from the bottom right action buttons.

It is also possible to modify only the action of previously registered output management points.

Click on the output management point name to be modified to enable action switchover.

Input management points can be removed by selecting the points to be removed from the list on the right-hand side (click the scroll bar if necessary) and clicking the **Remove <<** button.

Use the **+** and **-** buttons to modify the order of the output management point display. If everything is satisfactory, click the **OK** button. Clicking the **Cancel** button cancels the registration and the interlocking program setup screen is restored.

Next set up the output action. Select the condition from the drop-down list.

If "Not Detected" is selected, interlocking control cannot be carried out on the management point groups registered in Output1.

Sequential start time may be set up for multiple registrations of management points.

A similar procedure is used to register Output2.

If everything is satisfactory, click the **OK** button. Clicking the **Cancel** button cancels the interlocking program setup.

The interlocking/emergency program setup screen is restored.

---

Newly registered contents and modified contents are not saved if the operation is cancelled.

---

When "activated", the registered interlocking program executes.  
To execute the program, click on the program name displayed in the interlocking/emergency program screen (click the scroll bar if necessary). Then select the "Yes" option in the Activate frame.

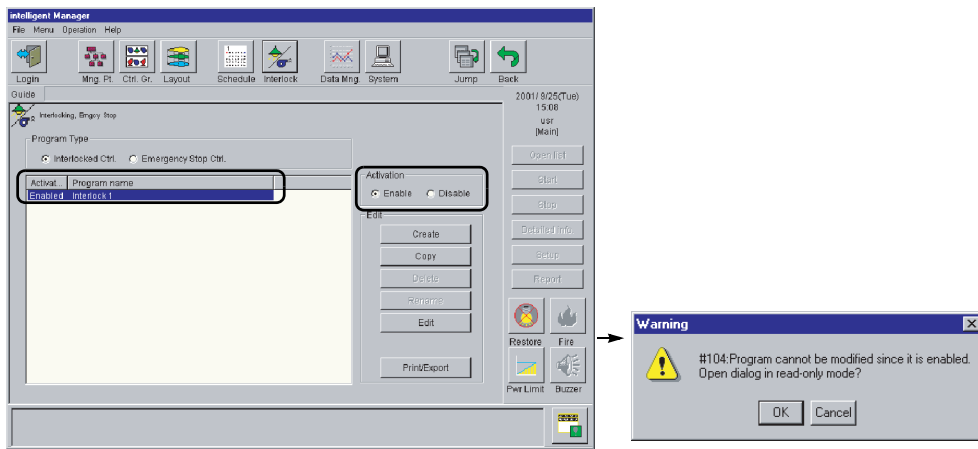

When modifying the content of a previously set up program, the program must be deactivated to allow modifications to take place.

Click on the program name and the **Copy Delete Rename** buttons to copy, delete and modify name respectively.

Set to "Disable" in the Activate frame when deleting or modifying names.

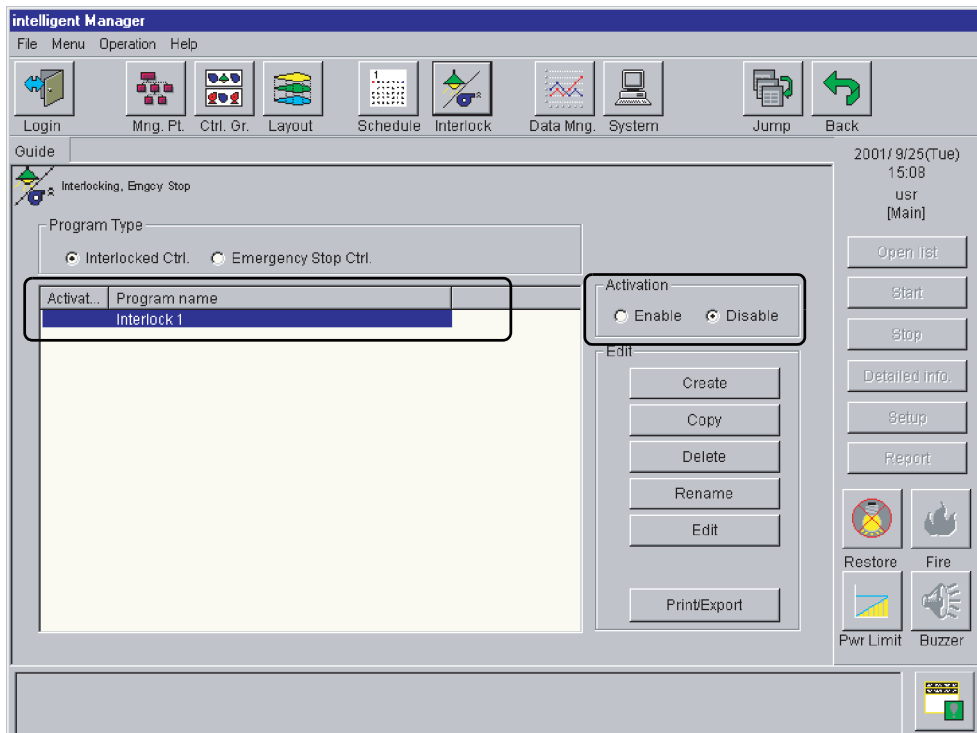

Enter the correct name and click the **OK** button. Cancel by clicking the **Cancel** button.

## 5.5.2 Setting up Emergency Stop Programs

Up to 32 Emergency Stop Programs may be registered.

Up to 6 input management points for monitoring and any number of output management points may be registered for every Emergency Stop Program.

The only output action of the Emergency Stop Program is to stop action.

Operation authority is required to edit the Emergency Stop Program.

The Emergency Stop Program may not be edited during an emergency stop.

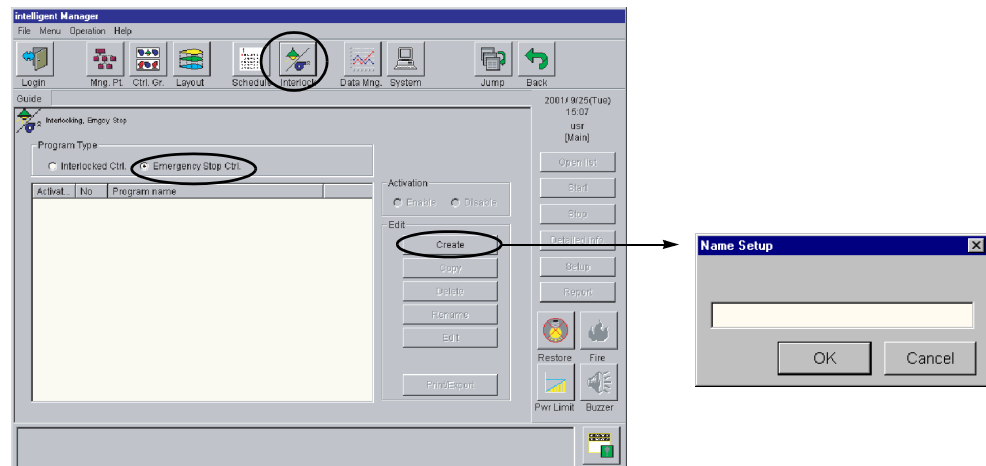

Select the Emergency Stop Program from the interlocking menu at the top of the screen.

Click the **Create** button to newly register the program.

The name setup screen will appear. Enter the name and click the **OK** button. To cancel the name setup, click the **Cancel** button.

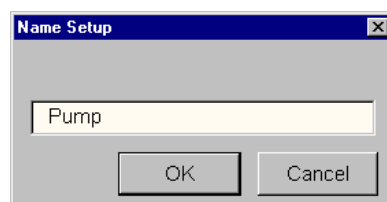

The newly registered program name is displayed on the screen.

Next set up the contents by clicking on the program name - click the scroll bar if necessary - to enable the operation buttons on the right-hand side.

Click the **Edit** button to display the Emergency Stop Program setup screen.

An interlocking program name or contents registered previously can also be modified via the same procedure. However the program to be modified should be disabled. (Refer to next page for details of enabling/disabling switchover).



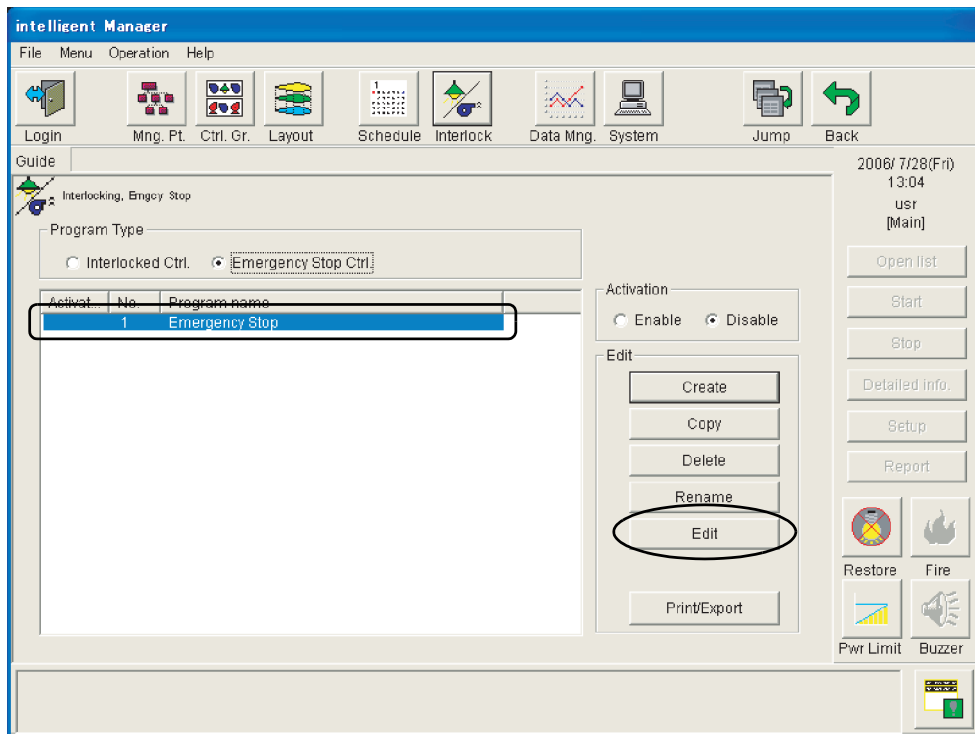

Click the **Edit** button in the Input frame to display the following management point selection screen.

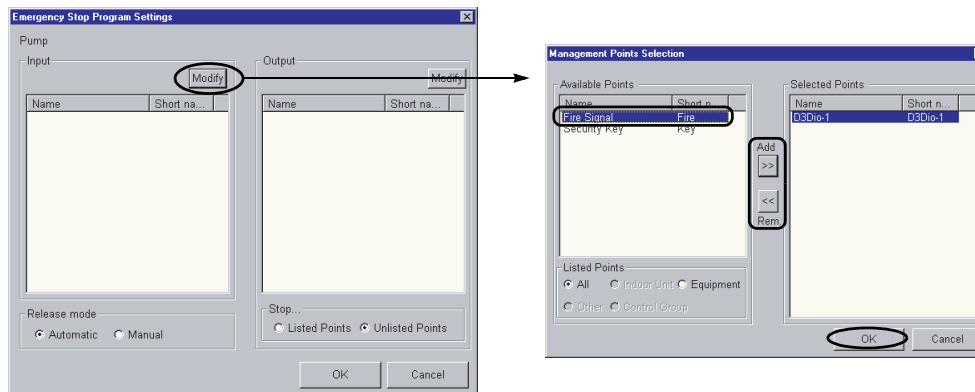

First select the detection condition.  
 Select a management point/control group. (Click the scroll bar if necessary). When satisfactory, click the **Add >>** button. A list of the input management points registered will appear on the right.  
 Input management points can be removed by selecting the points to be removed from the list on the right-hand side (click to roll down) and clicking the **Remove <<** button.  
 The previous interlocking program setup screen (see below) will be restored.

Output is then registered. Click the **Modify** button in the Output frame.

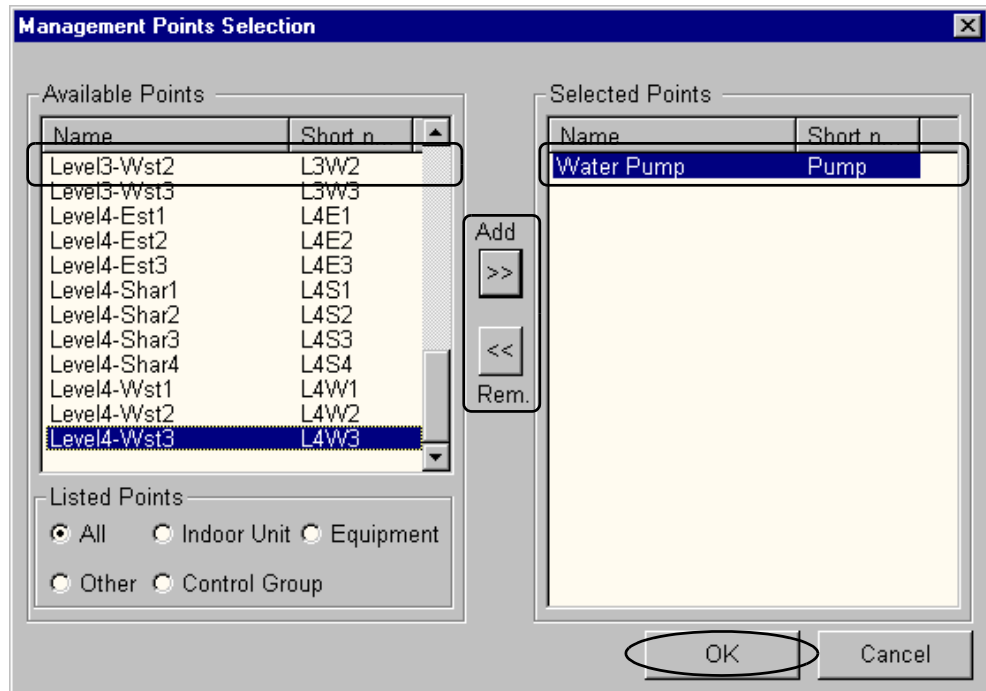

Select a management point from the available list. (Click the scroll bar if necessary). When satisfactory, click the **Add >>** button. A list of the input management points registered will appear on the right.

Input management points can be removed by selecting the points to be removed from the list on the right-hand side (click the scroll bar if necessary) and clicking the **Remove <<** button.

If the setup is satisfactory, click the **OK** button. The interlocking program setup is cancelled by clicking the **Cancel** button.

The previous Emergency Stop Program setup screen (see below) will be restored.

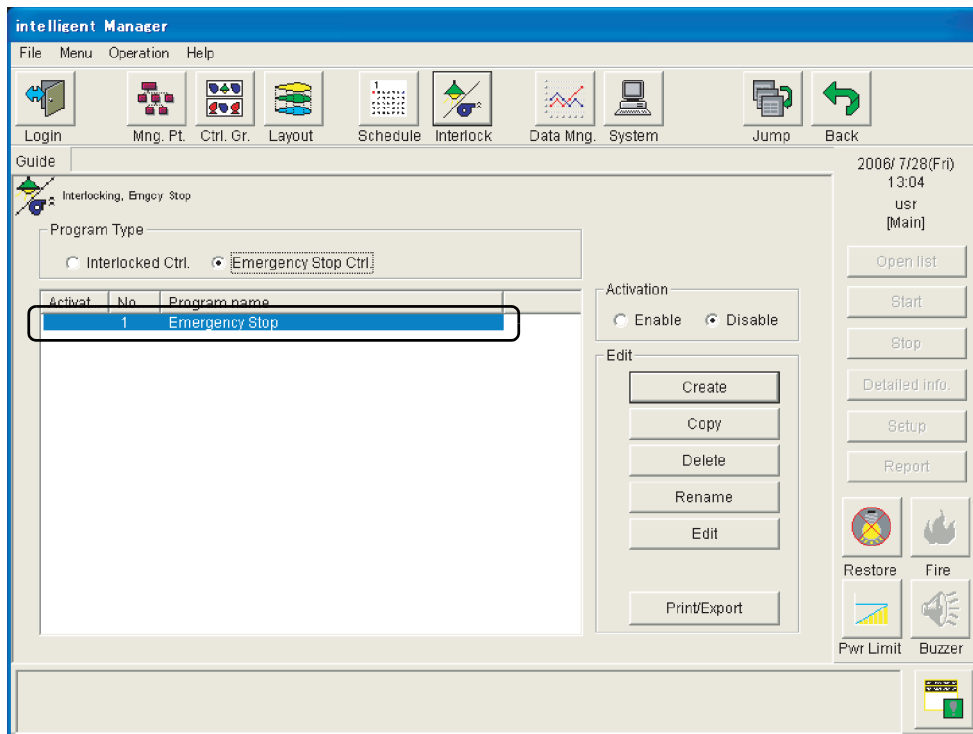

### Setting up the Release Mode

Automatically: emergency stop signals are automatically released when they are switched off.

Manually: once all emergency stop signals have been switched off, the specified program may be released manually.

#### Set up the specified Output Emergency Stop method

Depending on the Emergency Stop option selected, all listed output points or all output points other than those listed are stopped.

Listed points: specifies all the output management points to be stopped.

Unlisted points: all output management points other than those listed are to be stopped.

If the setup is satisfactory, click the **OK** button.

The Emergency Stop program setup is cancelled by clicking the **Cancel** button.

The previous Interlocking/Emergency Stop Program setup screen will be restored.

When "activated", the registered Emergency Stop program executes.

To execute the program, click on the program name displayed in the interlocking/emergency program screen (click the scroll bar if necessary). Then select the "Yes" option in the Activate frame.

When modifying the content of a previously set up program, the program must be deactivated to allow modifications to take place.

The program may not be deactivated during an emergency stop. Therefore the emergency stop must be released before deactivating the program.

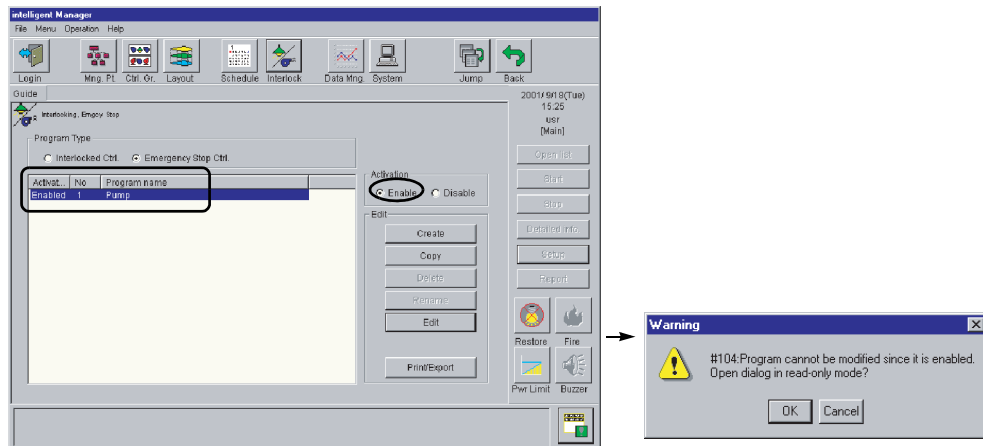

Click on the program name and the **Copy Delete Rename** buttons to copy, delete and modify name respectively.

Set to "No" in the Activate frame when deleting or modifying names.

Enter the correct name and click the **OK** button. Cancel by clicking the **Cancel** button.

## 5.6 Data Management

**Caution** This function of determining individual electrical power consumption is an ESTIMATION based on individual indoor units distribution load ratio and operating hours. It is not based on legal regulations from any governing body (such as "JIS" Japanese Law of Weighing calculation) and cannot stand up in a court of law. Collected data are saved in a daily report around midnight.

### 5.6.1 The Building Management applications

This function supports Building Management Business. External applications can be launched from the customizable buttons of this screen. When ship-ping, intelligent Manager is provided with an application for retrieving operational data from the intelligent Manager database. This application called intelligent Manager **Tenant Report Management** has two modules that are launched by the buttons **Tenant Setup** and **Tenant Report** as described in the two next sections.

**Note** The customization of the buttons (label as well as launched module) should have been performed beforehand by the installer (System Engineer) and is not explained in the current document.

Click the **Data Mng.** button from the menu buttons. The Data Management menu screen will be displayed.

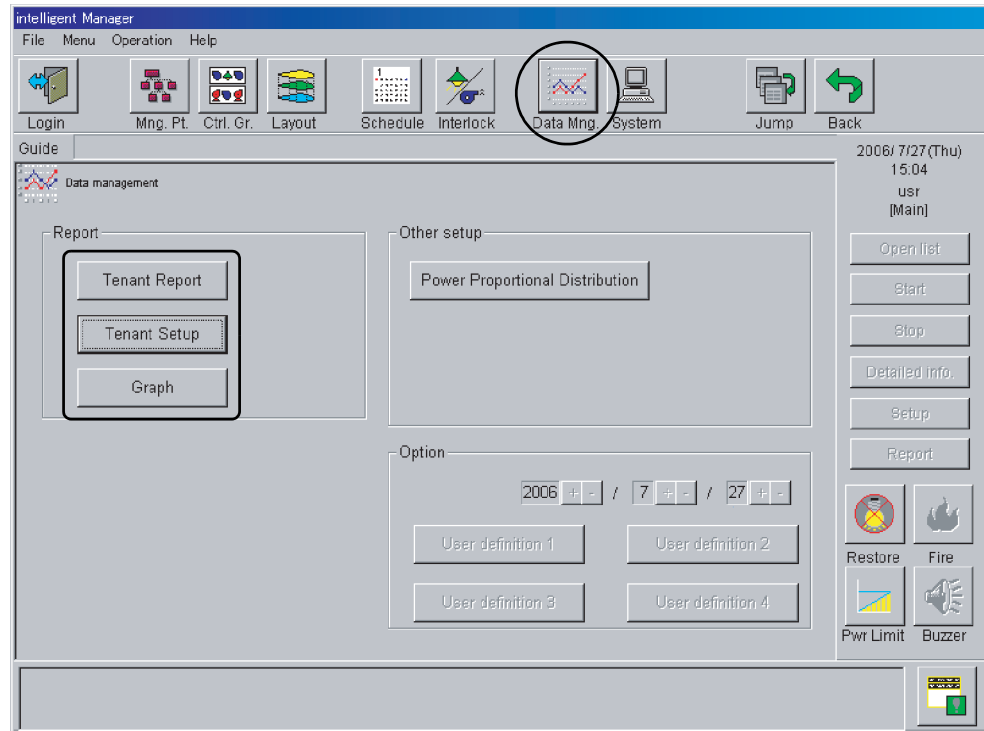

The reports are created in two steps, each with one of the modules of the application:

- **Step 1:** configure the tenants (this step can be performed once and then be reused)
  - Create the tenants
  - Associate to each tenant management points which data will be included in his report
- **Step 2:** retrieve the report data (this step can be performed on a regular basis on demand)
  - For each tenant, select the report limit dates and retrieve the operational data from the intelligent Manager database

### 5.6.2 Configuring the tenants

Click the **Tenant Setup** button to launch the tenant configuration module. The tenants with their information and management points' configuration setup are stored within the intelligent Manager database. Therefore, it is important to click the **Save Setup** button before exiting with the **Exit** button.

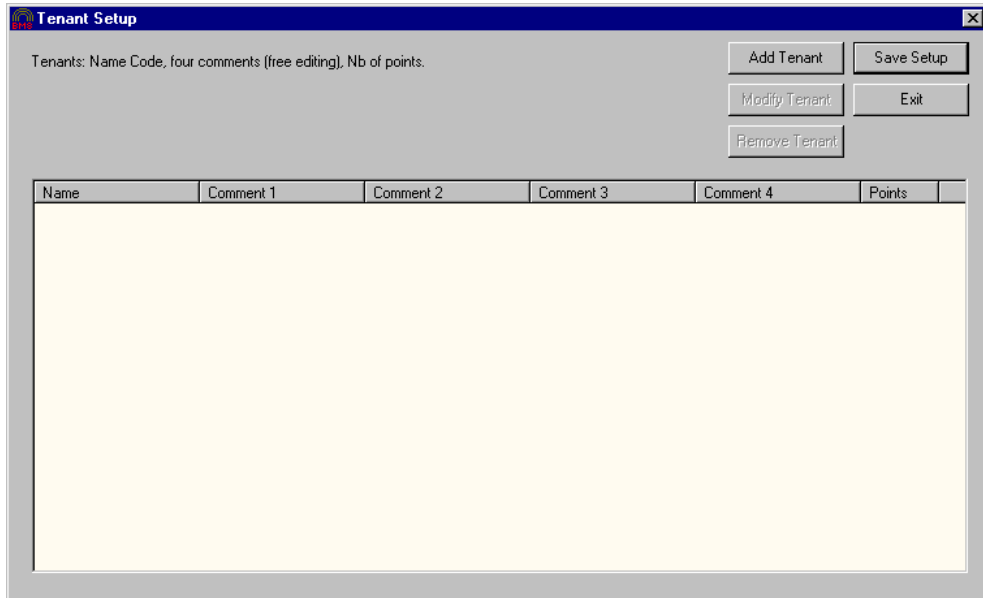

#### 5.6.2.1 Creating a Tenant

- (1) Click the **Add Tenant** button that will display the tenant configuration dialogue. The max number of tenants that can be registered is 100.

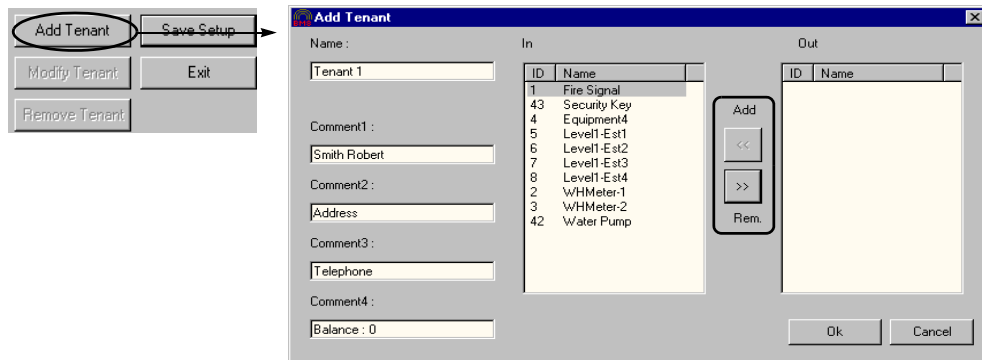

- (2) Enter the personal information of the tenant: its **name** (name duplication is not allowed) and its **comments** (up to 4 arbitrary values),
- (3) Select the points of this tenant from the **Out** list and click the << button to add them to his In list, click the >> button to remove them (a management point can belong to more than one tenant),
- (4) Click the **OK** button to validate this tenant.

The tenant with its personal information as well as the number of associated management points is displayed in a list as shown in the figure below.

#### 5.6.2.2 Modifying a tenant

It is possible to modify at any time both the personal information of a tenant (including its name) as well as his management points configuration.

- (1) First select an existing tenant from the displayed tenants list, then click the **Modify** button (if no tenant has been selected, an error message is displayed);

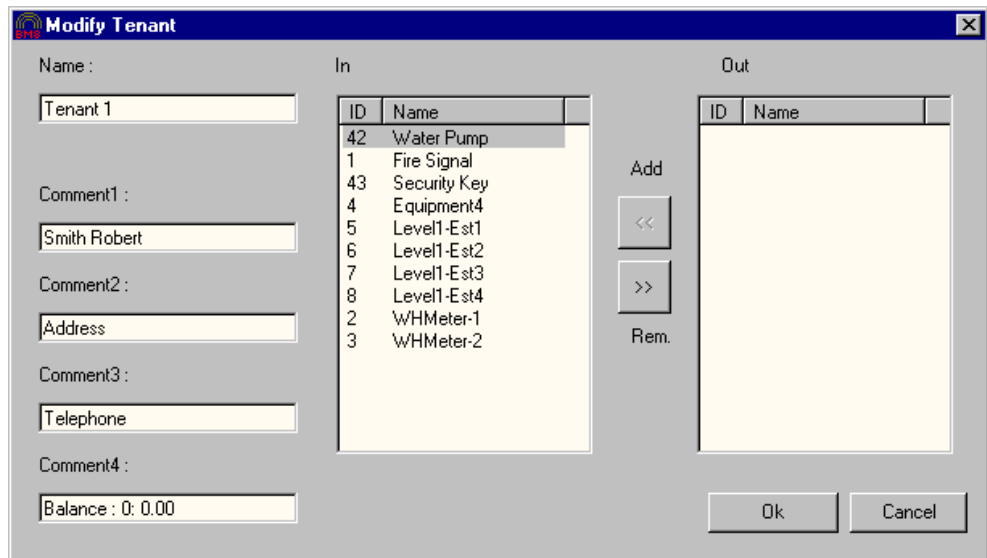
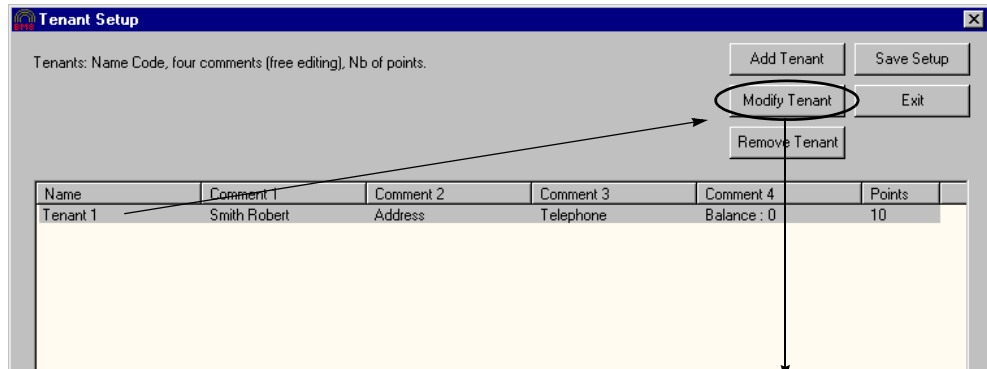

- (2) Perform as above from (2) to (4).

### 5.6.2.3 Removing a tenant

It is possible to delete a tenant from the list. Its personal information as well as management points configuration will be removed from the configuration file.

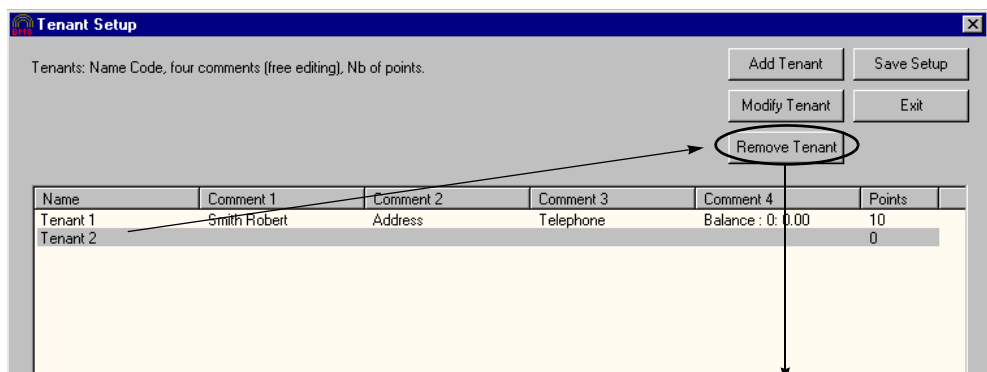

- (1) Select a tenant as above in (1);
- (2) Click the **Remove Tenant** button;
- (3) Confirm in the warning message box to validate the deletion.

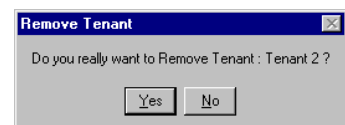



5.6.2.4 *Exiting the report setup application*

The configuration file is stored within the intelligent Manager database. Click the **Save Setup** button as shown in the figure below to update it. Then, the operation buttons are deactivated until transfer completion is notified. Click the **OK** button to acknowledge the backup completion.

After the configuration has been saved, click the **Exit** button. A confirmation box appears warning if the configuration has not been saved.

Click the **Yes** button to exit, or the else click the **No** button to return to the tenant setting application.

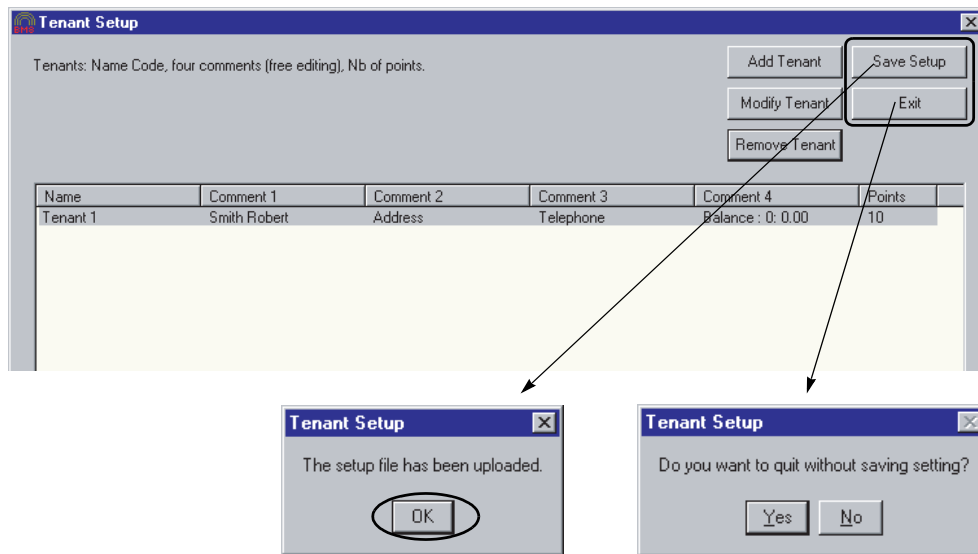

5.6.2.5 *Creating a report*

This module extracts from the intelligent Manager database the operational data for the management points of the tenant, making use of the previously set up configuration.

Click the **Report** button to launch under **Tenant Report** module.

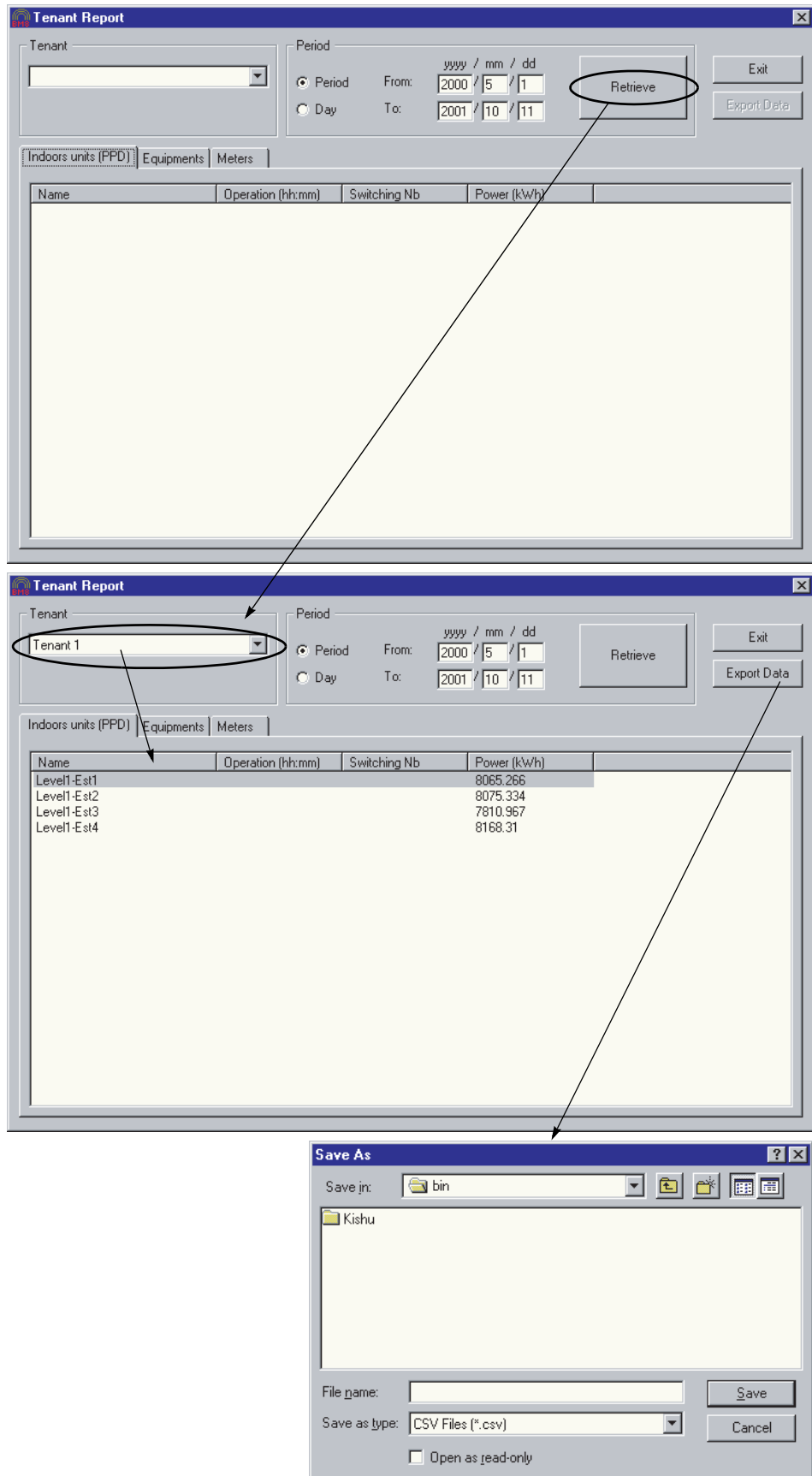

For each tenant and each period, perform as follows:

- (1) Select a report type from the option and enter the appropriate period:
  - **Daily:** the date of the data to be retrieved;
  - **Period:** the date of the first and last day of the data to be retrieved (and cumulated).
- (2) Click the **Retrieve** button, then the list of tenants displays;
- (3) Select the **Tenant** from the drop-down list;
- (4) **Export** the data in csv format, then making use of a worksheet editor, manipulate the retrieved data at will (select/copy/paste, save in an other worksheet, etc.).

After retrieving the data of each tenant for the period, click the **Exit** button to close the application

### 5.6.3 Graphical Report

#### 5.6.3.1 Introduction

The purpose of the Graphical Report function is to visualize graphically the daily evolution of pulse value and equipment or indoor unit running time. The graphical Report function makes also possible the graphical visualization of trend and daily value of analog management points.

In addition the function also makes possible printing of graphics and export of graphics data under the CSV format for further processing.

### 5.6.3.2 Starting the Graph function

Click on the **Data Mng.** button of the intelligent Manager software to display the **Data Management** screen. In this screen's Option frame click on the **Graph** button to launch the Graphical Report function.

The Graphical Report function's main screen is as shown below.

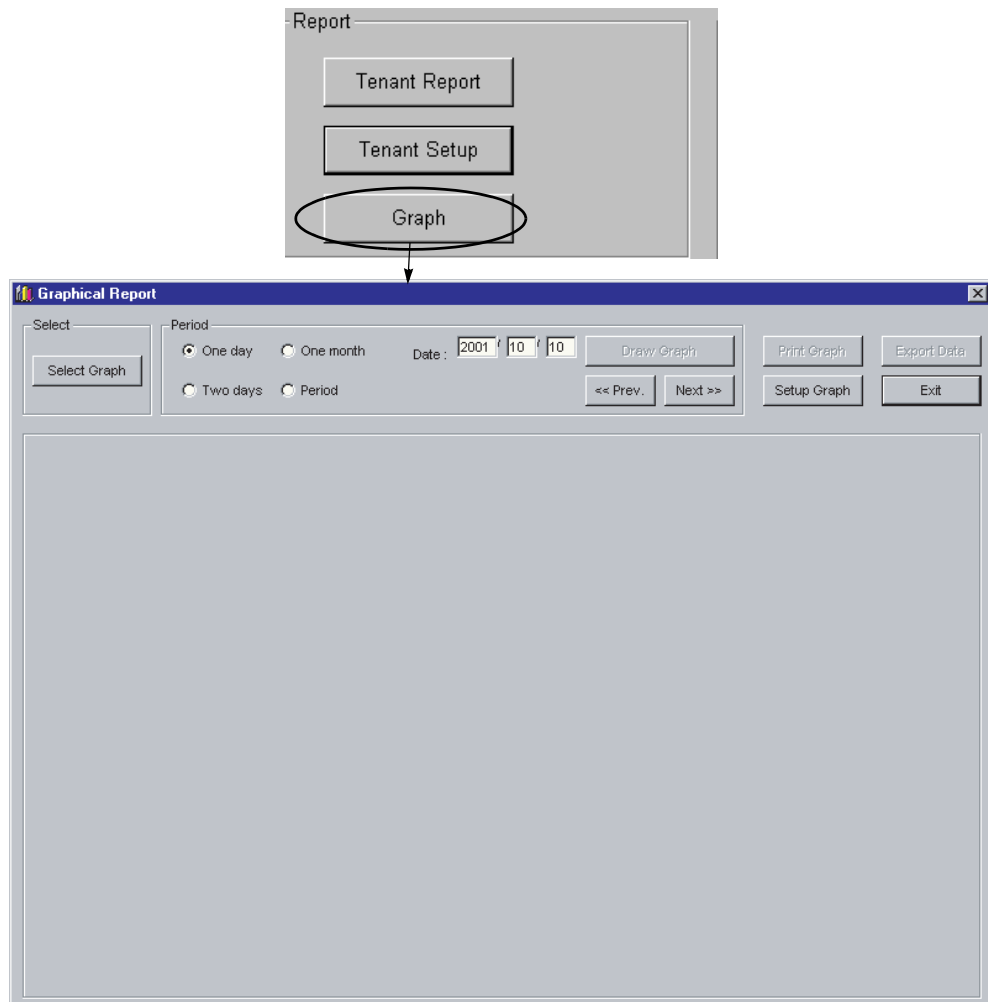

### 5.6.3.3 Setting up "Graphs"

When using the function for the first time, it is necessary to setup "Graphs".

- A "Graph" is a bundle of management points whose values will be displayed on the same graphic.
- A single management point may belong to more than one "Graph".
- The number of management points in a "Graph" is limited to 4.
- The number of different types of point (i.e. with different units) in a "Graph" is limited to 2.
- The number of "Graphs" is limited to 500.

To set up "Graphs", click on the **Setup Graph** button. The Graph Setup dialog displays, as shown below.

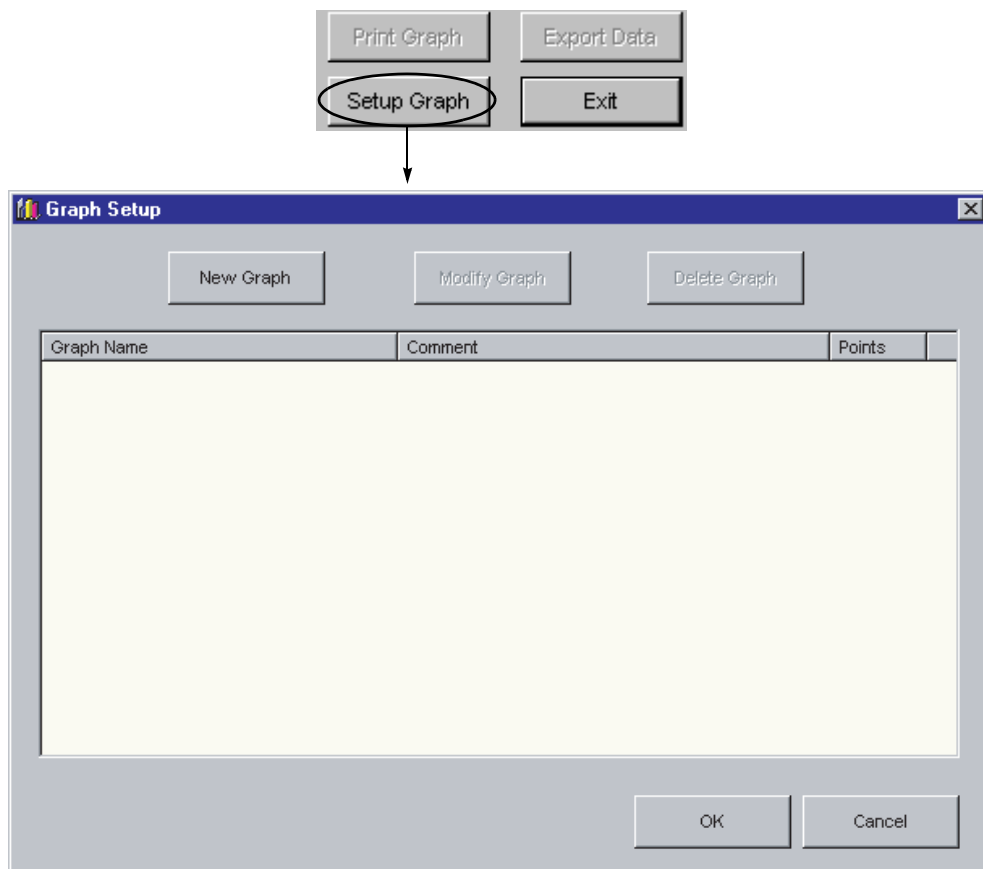

## (i) Creating a new "Graph"

To create a new graph, click on the **New Graph** button. The **New Graph** dialog displays as shown below.

The 'New Graph' dialog box contains the following elements:

- Available Management Points:** A table with two columns: 'Mng. Point Name' and 'Unit'.
 

Mng. Point Name	Unit
Equipment4	h
External Temperature	deg
Fire Signal	h
Level1-Est1	h
Level1-Est2	h
Level1-Est3	h
Level1-Est4	h
Security Key	h
Water Pump	h
WHMeter-1	kWh
WHMeter-2	kWh
- Displayed Types:** Four radio buttons: 'All' (selected), 'Indoor Unit', 'Equipment', and 'Other'.
- Add:** A '>>' button to move items from the available list to the graph content.
- Rem.:** A '<<' button to move items from the graph content back to the available list.
- Graph Content:** An empty table with columns 'Mng. Point Name' and 'Unit'.
- Graph Name:** A text box for entering the name of the graph.
- Comment:** A text box for entering an optional comment.
- Buttons:** 'OK' and 'Cancel' buttons at the bottom right.

Input the graph name in the **Graph Name** text box. Also input an optional comment in the **Comment** text box.

**Note**

Both Graph Name and Comment are limited to 32 characters.

The management points belonging to a Graph are selected from the list of available management points and added by clicking the **Add >>** button.

To remove a management point from the Graph, select the management point to be removed from the Graph content list and click the **Rem. <<** button.

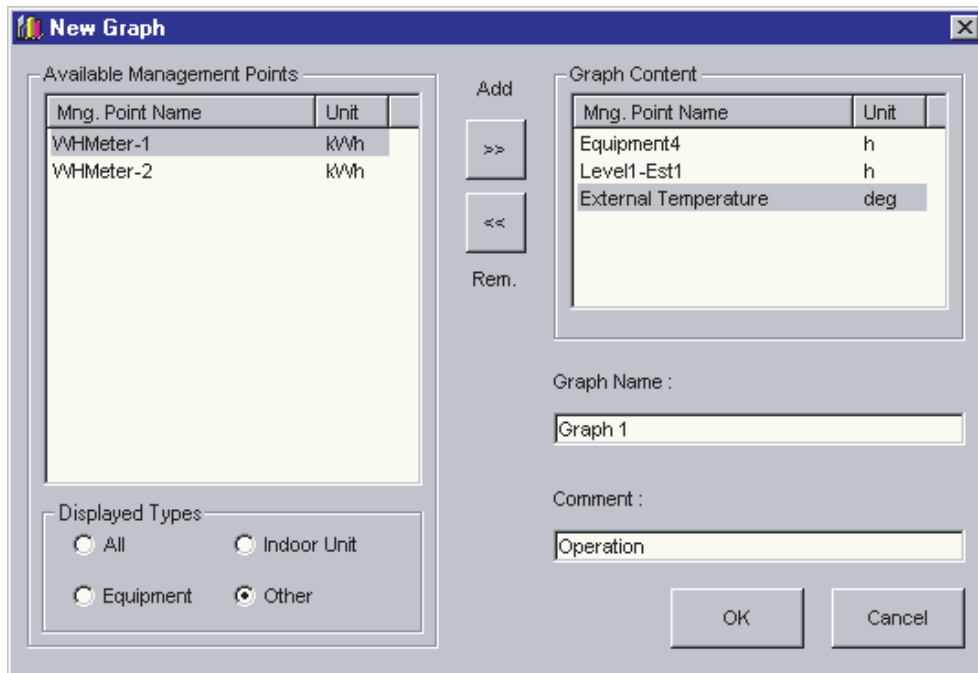

Use the option button to modify the type of the points displayed in the list of available management points. **Equipment** includes Di, Do and Dio management points. **Other** includes Ai, Ao and Pi management points.

If there is no management point, or if limit of number of management points, different types of point (i.e. different units) is exceeded, a warning message displays as shown below.

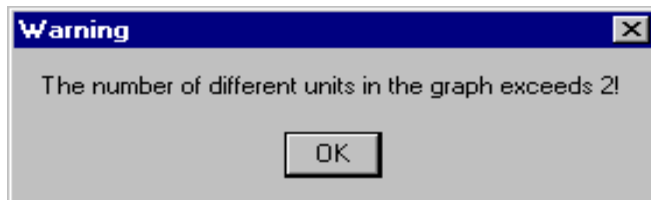

Click the **OK** button to save the new graph as shown in the figure below, or click the **Cancel** button to exit the dialog without saving the new graph settings

(ii) Modifying a graph

To modify a graph, first select it in the list, and then click on the **Modify Graph** button.

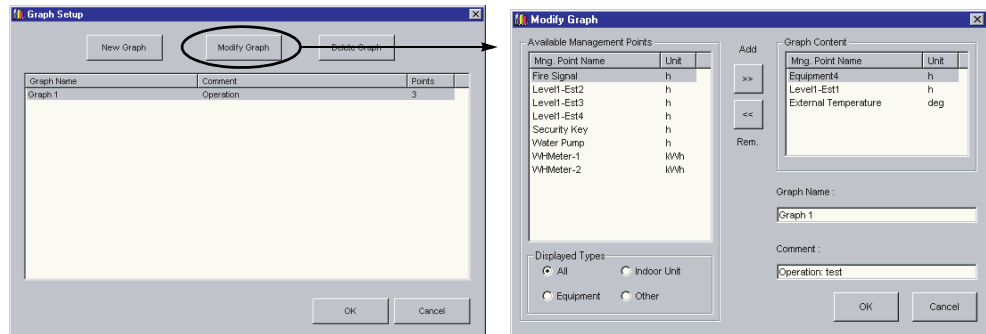

Perform as explained in **(i) Creating a new "Graph"** (p. 65) to modify the selected graph parameters.

After modifying parameters, click the **OK** button to save the graph new parameters, or click the **Cancel** button to leave the parameters unchanged.

**(iii)Deleting a graph**

To delete a graph, first select it in the list, and then click the **Delete Graph** button. A confirmation dialog displays as shown below. Click **Yes** to confirm the deletion or **No** to cancel it.

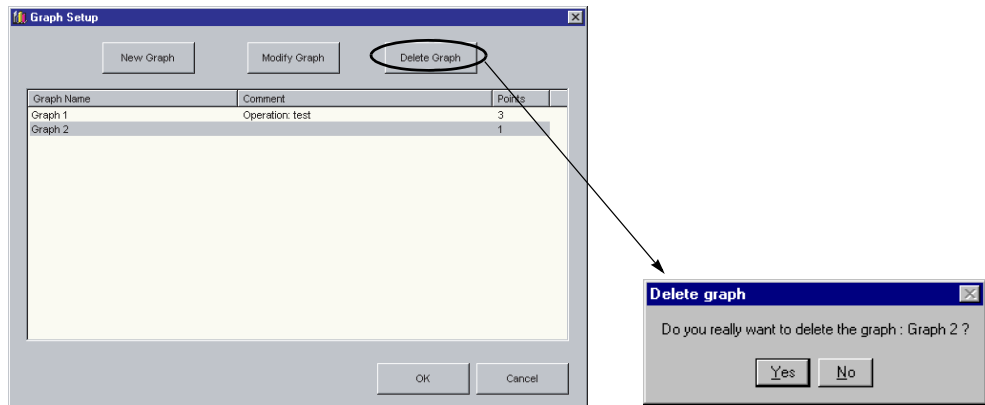

**(iv)Exiting Graph Setup tool**

Click on the **OK** button to save the modifications of the Graphs by updating the Graphs setting file. Click the **Cancel** button if you which to cancel the modifications and leave the Graphs setting unchanged.



5.6.3.4 Drawing a graph

(i) Selecting a graph

Select the graph to be drawn. Click on the **Select Graph** button to display the list of available graphs as shown below.

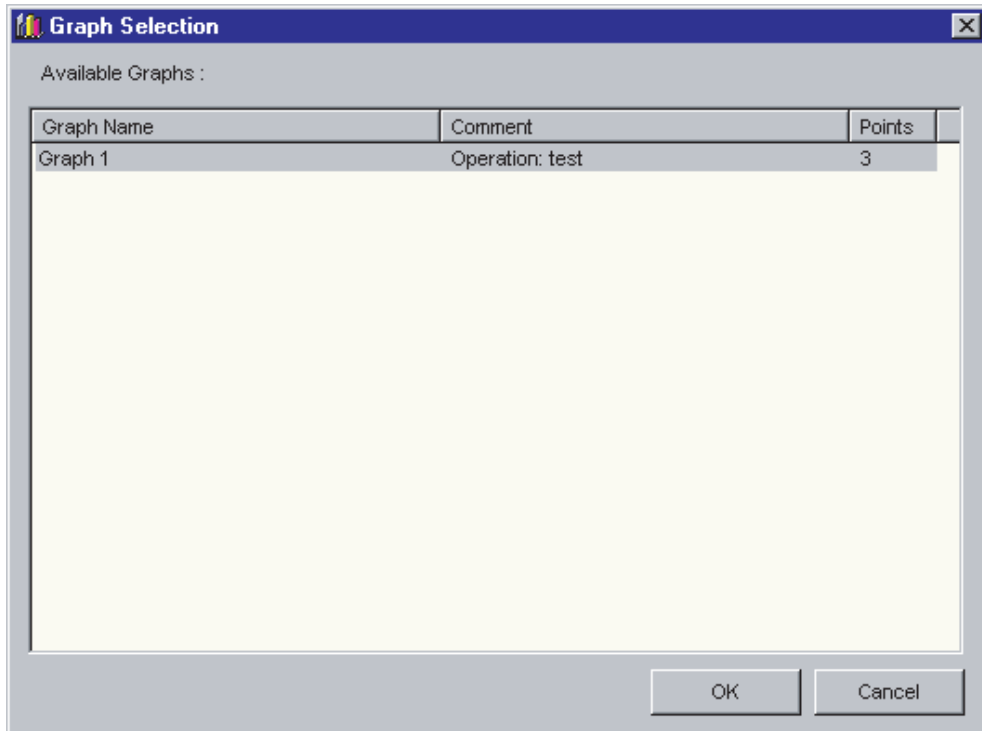

Select a graph in the list and click the **OK** button to update current selection. To exit the dialog without updating the current selection, click on the **Cancel** button.

(ii) Selecting a period

Select the period for which the data have to be displayed. This can be a **One Day** period, a **Two Days** period, a **One Month** period or a free **Period**. Use the option button to select the period type as shown below.

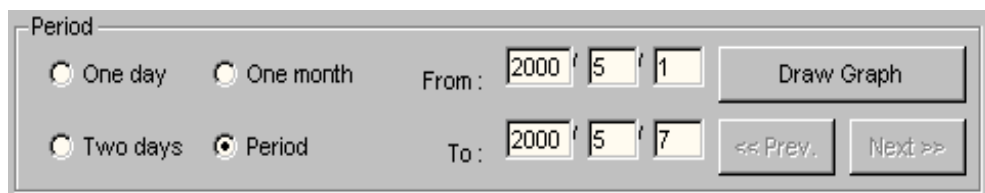

Input the date or month, the starting date, or the start and end dates according to the period type in the corresponding fields (YYYY/MM/DD).

Use the **<< Prev.** and **Next >>** buttons to remove or add one day to the date or starting date, in the case the period is a one day or a two days period.

Use the << **Prev.** and **Next** >> buttons to remove or add one month to the month in the case the period is a one month period.

**Note**

- A One Day period is a 24 hours period starting at midnight of the inputted date.
- A Two Days period is a 48 hours period starting at midnight of the inputted date.
- A One Month period is a period starting at midnight of the first day of the inputted month and ending at 23.59 of the last day of the inputted month.
- A Period is a period starting at midnight of the inputted start date and ending at 23.59 of the inputted end date.

(iii) Drawing the graph

To draw the graph, click on the **Draw Graph** button.

Analog management point and indoor units - one-day period

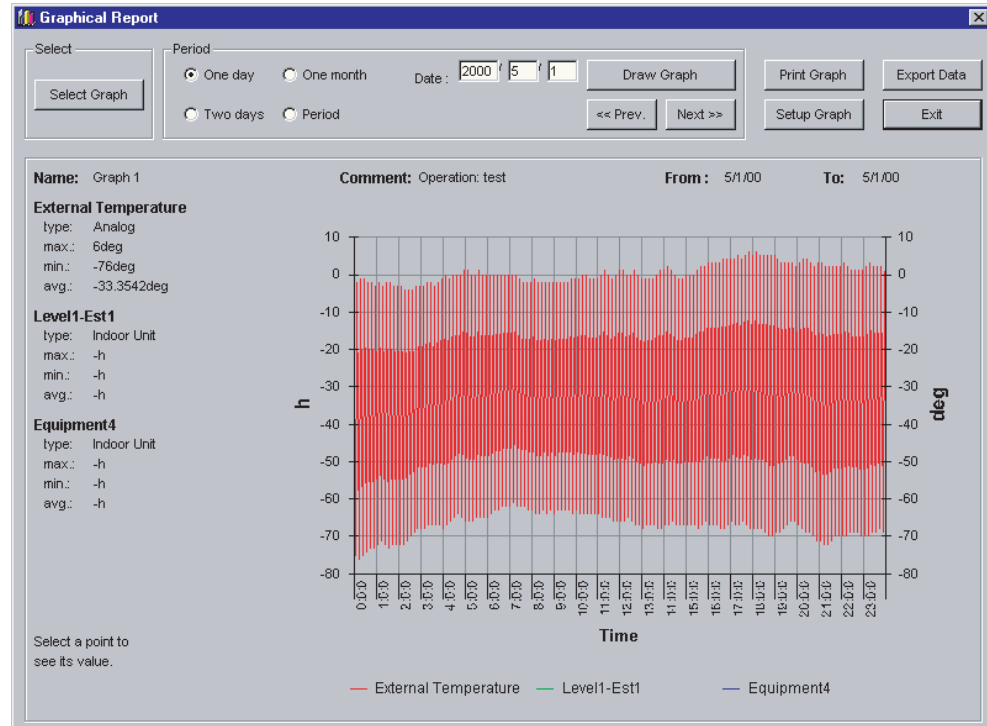

Indoor units -  
one-month  
period

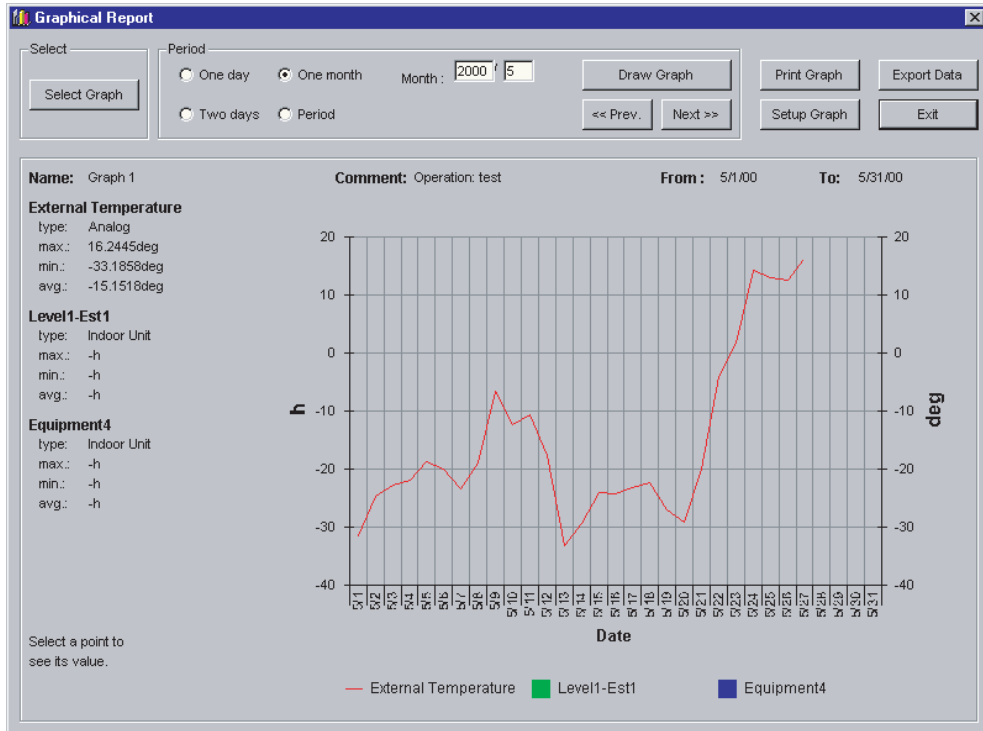

The top part of the graphic frame displays the Name and comment of the Graph as well as the data, start date and end date, depending on the period type.

The left part of the graphic frame displays information about each management point in the graph: its name, its maximum and minimum value over the period as well as its average value over the period.

In the case of a pulse management point, a equipment or a indoor unit, if the period type is a one day period only the value for the day is displayed, as the maximum, minimum and average are all equal.

**Note**

- If no data could be retrieved for the period or if all data for the period are invalid, a "-" is displayed instead of the value.
- After modification of the period type or range, or after modification of the current selection, click the **Draw Graph** button to update the display graphic.
- X Axis scale is:
  - 1 mark & 1 label / hour in case of a one day or two day period.
  - 1 mark & 1 label / day in case of a one month period or free period more than 2 days and less or equal to 31 days.
  - 1 mark & 1 label / 2 days in case of a free period of more than 31 days and less or equal to 61 days.
  - 1 mark & 1 label / 4 days in case of a free period of more than 61 days and less or equal to 122 days.
  - 1 mark & 1 label / 7 days in other cases.

- Analog values are displayed using lines for every type of period.
- Pulse, equipment and indoor units are displayed using bars for period of longer than 2 days and lines for period shorter or equal to 2 days.
- Displayed values (See table below):
  - For analog points, trend value is displayed for period less or equal to 2 days.
  - For period longer than 2 days, daily average value is displayed.
  - For other type of management points daily value is displayed for every type of period.

	1 day	2 days	1 month	period > 2 days
<b>Analog</b>	Trend value	Trend value	Daily value	Daily value
<b>Pulse</b>	Daily value	Daily value	Daily value	Daily value
<b>Equipment/ Indoor Unit</b>	Daily value	Daily value	Daily value	Daily value

(iv) Displaying a point value

To display the exact value of a point at a given time, click on the point of the curve you want to know the exact value as shown below.

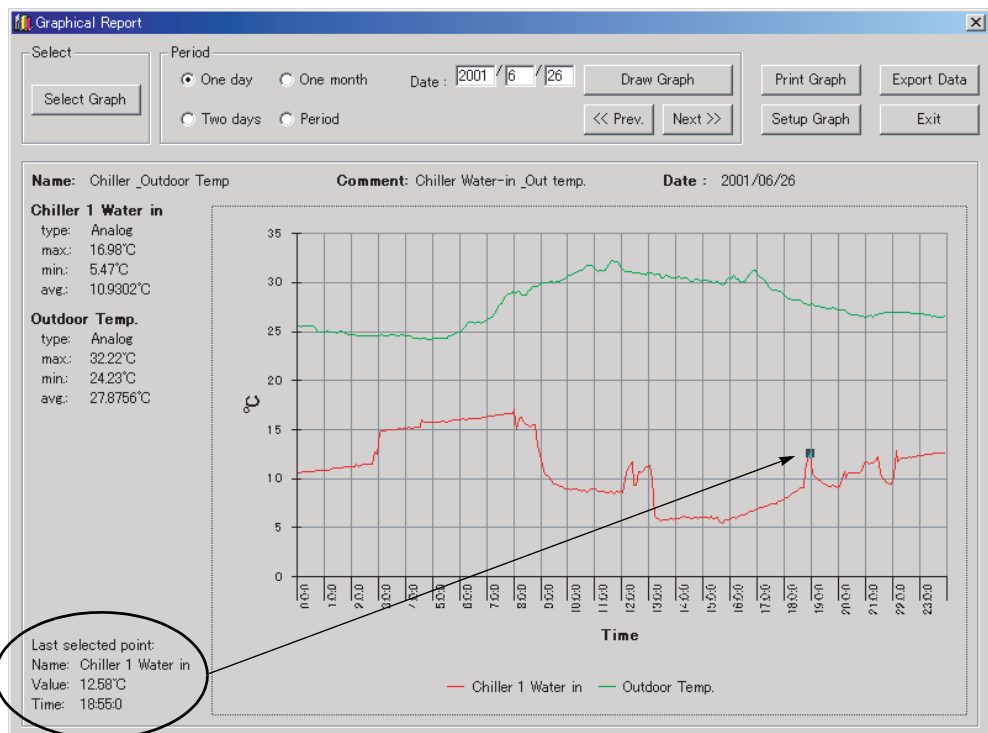

5.6.3.5 Printing a graph

To print a graph, click on the **Print Graph** button. The graphic will be printed on the system printer.

### 5.6.3.6 Exporting a graph data

To export a graph data in the CSV file format (which can be opened with text editor or Microsoft Excel for example), click on the **Export Data** button. The following dialog displays. Choose the folder, input the file name and click the **Save** button.



The CSV file contains information about the Graph (Name, Comment), the period (From, To). It also contains information about every member management point (Point Name, Point ID, Point Type, Unit).

---

**Note**

Point Type:  
 1 = Equipment (Di, Do, Dio)  
 2 = Pulse (Pi)  
 3 = Analog (Ai)  
 4 = Indoor Unit, HRV, Chiller, AHU

---

Maximum, Minimum and Average value over the period are also displayed for every management point as well a data (Date/Time, Value and Validity).

### 5.6.4 Setup of Power Proportional Distribution (option)

---

**Note**

When you use this function, be sure to inform the person in charge of system setting in advance. When this function is used, power proportional distribution cannot be calculated.

---

If this optional function is present in your configuration, the power used by the outdoor units can be divided between the indoor units and equipment as initially configured in the engineering procedure. By using this dialogue, it is possible to determine when this proportional division should be performed or not.

- Exclusion time zones (time zones in which power division is not calculated proportionally) may be set up on any day of the week.
- Regardless of exclusion time zone setup, special days may be set up on the calendar (in this case the whole day is calculated, regardless of normal setup).

Click the **Power Proportional Division Setup** button.

The screen will appear as shown below.

**Electric Power Proportional Division**

Special Fee Days (Normal Pattern)

2001 year   Special Day

Sun	Mon	Tue	Wed	Thu	Fri	Sat
	1	2	3	4	5	6
7	8	9	10	11	12	13
14	15	16	17	18	19	20
21	22	23	24	25	26	27
28	29	30	31			

Exclusion Period (Normal Pattern)

	All Day	Period	Morning	Evening	hr.	min.	~	hr.	min.								
<input type="checkbox"/> Sun	<input checked="" type="radio"/>	<input type="radio"/>	<input type="radio"/>	<input type="radio"/>	0	+	-	0	+	-	~	24	+	-	0	+	-
<input type="checkbox"/> Mon	<input checked="" type="radio"/>	<input type="radio"/>	<input type="radio"/>	<input type="radio"/>	0	+	-	0	+	-	~	24	+	-	0	+	-
<input type="checkbox"/> Tue	<input checked="" type="radio"/>	<input type="radio"/>	<input type="radio"/>	<input type="radio"/>	0	+	-	0	+	-	~	24	+	-	0	+	-
<input type="checkbox"/> Wed	<input checked="" type="radio"/>	<input type="radio"/>	<input type="radio"/>	<input type="radio"/>	0	+	-	0	+	-	~	24	+	-	0	+	-
<input type="checkbox"/> Thu	<input checked="" type="radio"/>	<input type="radio"/>	<input type="radio"/>	<input type="radio"/>	0	+	-	0	+	-	~	24	+	-	0	+	-
<input type="checkbox"/> Fri	<input checked="" type="radio"/>	<input type="radio"/>	<input type="radio"/>	<input type="radio"/>	0	+	-	0	+	-	~	24	+	-	0	+	-
<input type="checkbox"/> Sat	<input checked="" type="radio"/>	<input type="radio"/>	<input type="radio"/>	<input type="radio"/>	0	+	-	0	+	-	~	24	+	-	0	+	-

Print/Export

#### Exclusion Time Zones (usual format)

Check the Exclusion Time setup day check box. Use the radio buttons to select the day, time zone option (whole day, within the time zone, or outside of the time zone) and set the time zone if necessary with the + - buttons.

#### Special Day Setting (usual format)

Calendar can be set up with special days for which the exclusion time zone setup does not apply. Click on a date to set it up as a special day to be displayed in red. Clicking again cancels the setup.

Example of setup screen.

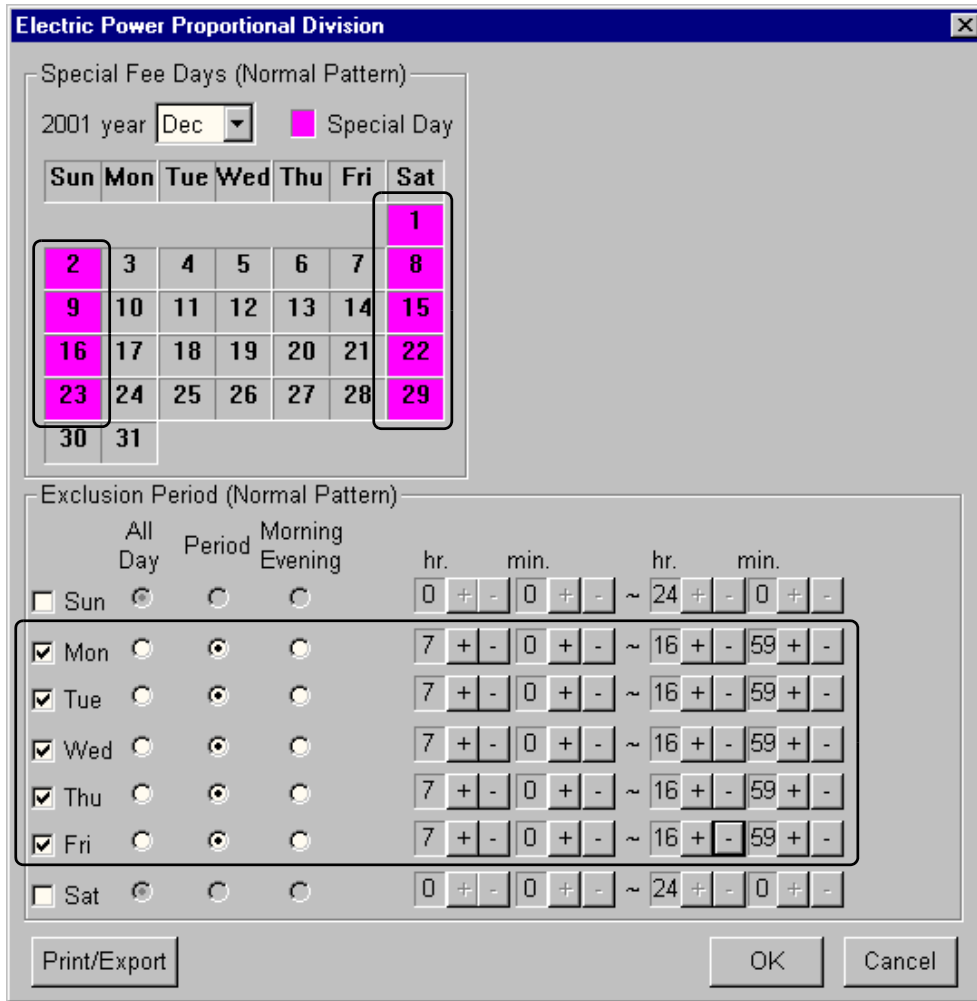

Click the **OK** button to validate the setup content. Clicking the **Cancel** button invalidates the setup content.

**Important** This dialogue set up the period when the power is NOT proportionally divided. Therefore, unchecked boxes as well as the special days of the calendar mean that the division is carried out all day.

### 5.7 System options

In order to meet the requirements of every user in the best possible way, various setup functions are available.

These are known as the system setup.

To carry out a system setup, the appropriate authority - such as "system setup authority" - is required.

The system setup has the following setup functions.

- Points Management:
  - Management group setup;
  - Control group setup;
  - Management point attribute setup.

- User environment:
  - Login setup;
  - Confirmation dialog setup;
  - Centralized control setup;
  - Buzzer setup;
  - History setup.
- System Time:
  - Time (clock) setup;
  - Daylight saving Time setup.
- Automatic control:
  - Automatic Change Over;
  - Sliding Temperature;
  - Temperature Limit;
  - Heating Mode Optimization.

Click the **System** menu button. The system shown below will be displayed.

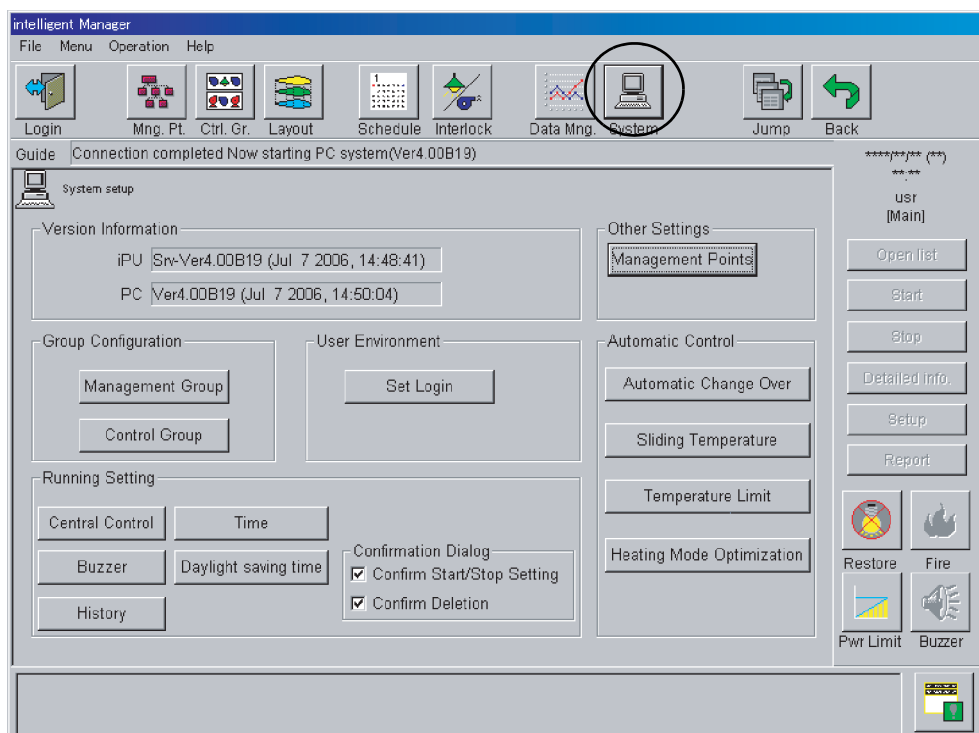

Click the button of the item to be setup to display the setup dialog.

### 5.7.1 Configuring Management Groups

- Management groups can be named at will.
- Icons indicating a management group is automatically assigned a group icon. (No modification possible).
- The layered structure of the management groups is automatically displayed in the management group list.
- Management group operation authority is required to operate a management group.
- Management Groups can be printed out either (on the default printer) or exported into CSV (comma separated) format files.

\* As cell size and arrangement are similar to those of a control group, refer to **5.7.2 Configuring Control Groups** (p. 79).



### Operational Procedure

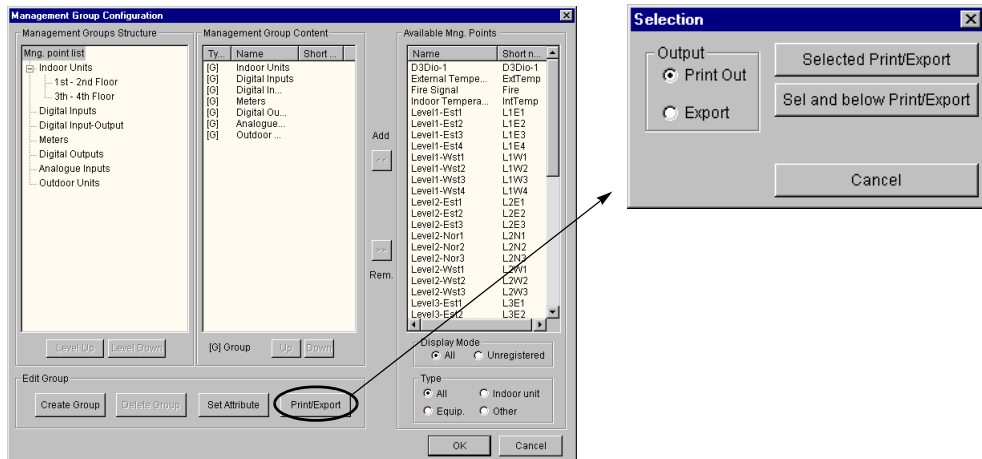

Select the management group to which the group to be created will belong.  
 Click on the **Print/Export** button to print on the system printer or export to a text file either the currently selected group or all the groups.

Enter the group name and click the **OK** button.

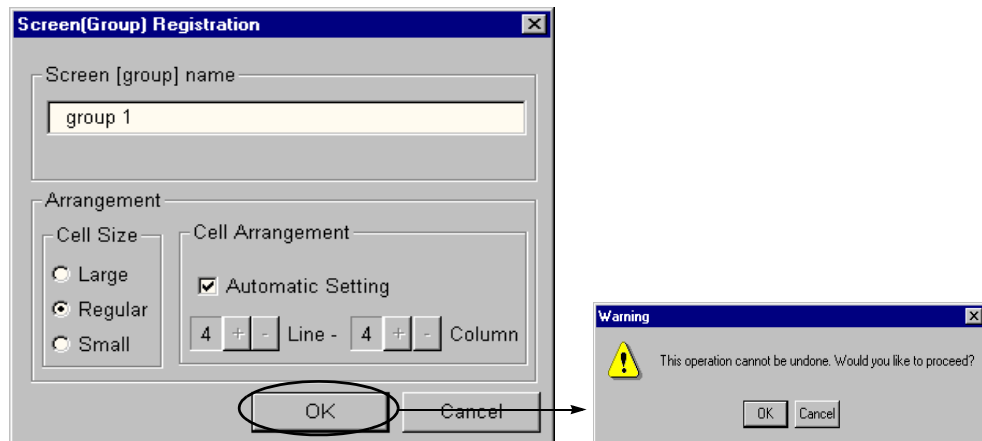

A warning box will appear at the time of the first operation.  
 Click the **OK** button to proceed with the operation or the **Cancel** button to cancel it.

The new group will then be displayed in the management group structure.  
 The level of this group in the tree structure can be modified by clicking the **Level Up** and **Level Down** buttons.

As well, the position in the sub-tree can be modified by clicking the **Up** and **Down** buttons.

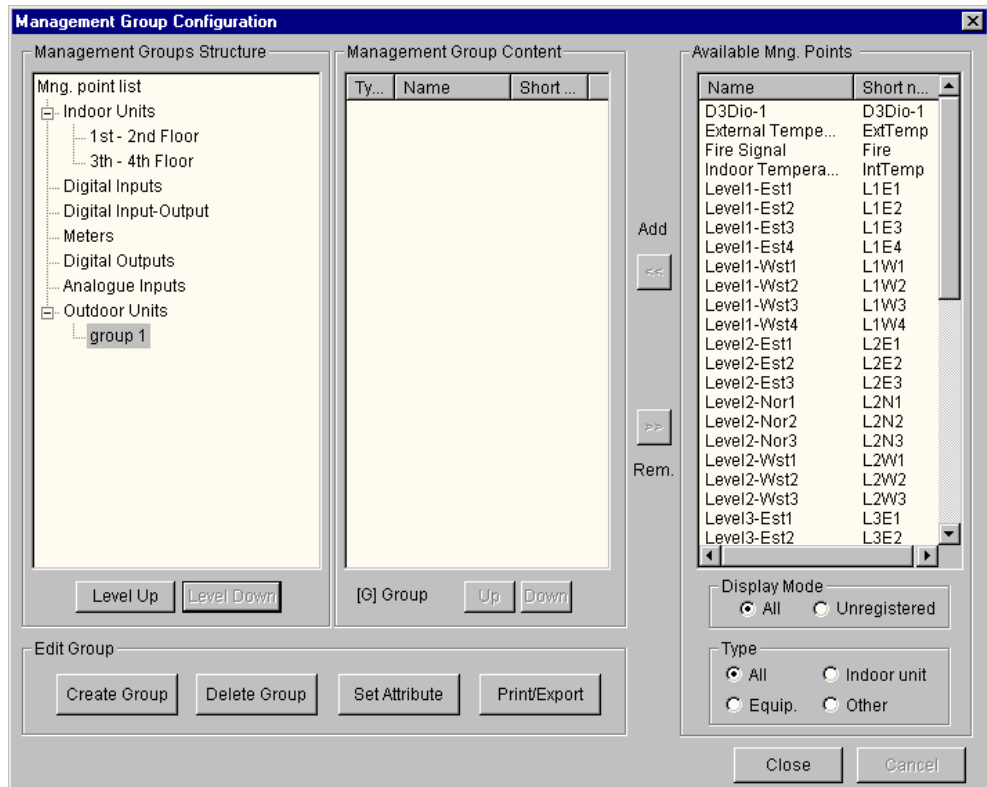

The management points belonging to this group are selected from the list of available management points and added by clicking the **Add <<** button. To remove a management point, select the management point to be removed from the management group content list and click the **Remove >>** button.

When a management point is registered, it will be displayed as in the screen below.

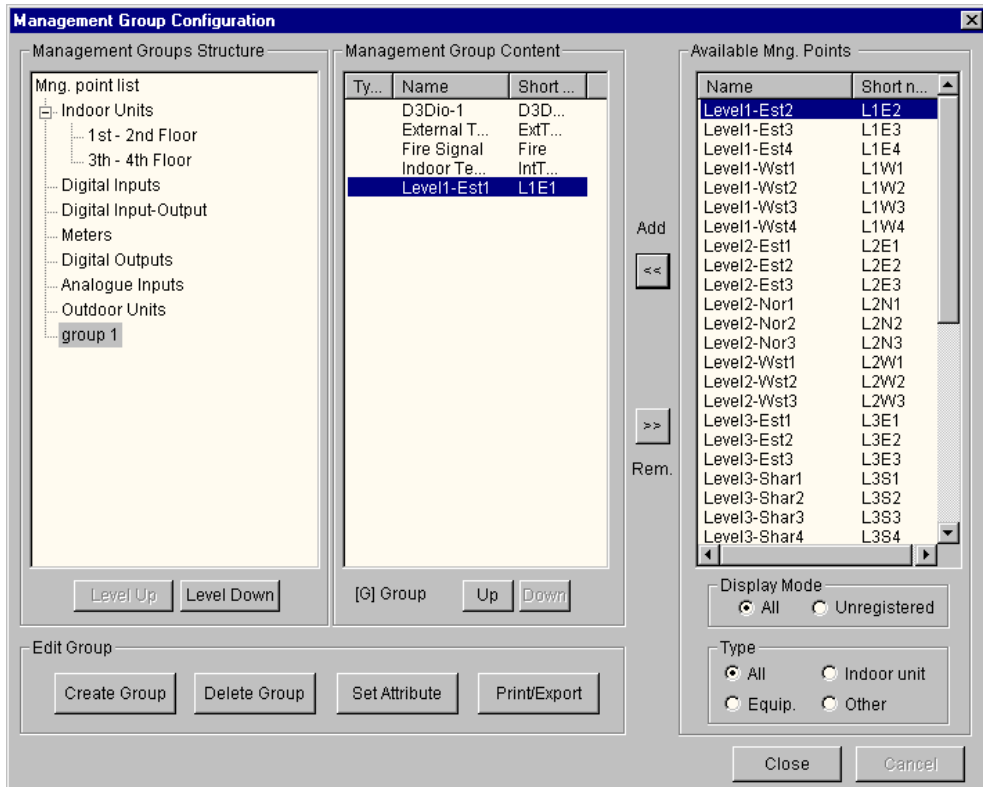

When all registrations have been completed, click the **Close** button.

Additionally, if a management point group needs to be deleted, select the management point group to be deleted and click the **Delete Group** button. If a management point group needs to be renamed, select the management point group to be modified and click the **Set Attributes** button. A group registration dialog box will appear, thereby allowing name and arrangement specification to be modified.

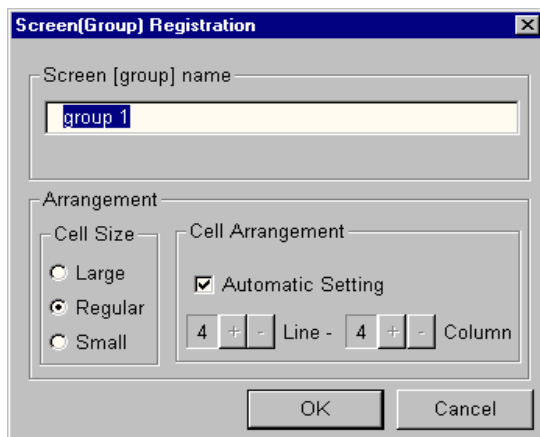

### 5.7.2 Configuring Control Groups

- It is allowed to prepare 200 control groups at the maximum. It is allowed to register 1024 management points at the maximum in each control group.
- Control groups can be named at will.
- Icons indicating a control group can be setup at will as representative icons.
- The control groups created by the control group operation are automatically displayed in the control group list.
- Control group operation authority is required to operate a control group.
- The order of the registered management points, the sequential startup time interval at the time of collective start and the sequential stop time interval at the time of collective stop (0, 10, 20, 30 or any number of seconds from 0-180) can be specified in a control group. A sequential startup (stop) time interval is the time elapsed between instructions.
- \* This assumes that if collective running time is started up sequentially, the peak electric electrical power load required at startup will be reduced.
- Both management points with Start/Stop capability and management points for monitoring only can be set up as control group members.
- If an instruction - such as collective startup - is issued to a control group while it is being edited (registration/deletion of management points or modifications of the time interval), the modification will come into effect for subsequent instructions only.
- Control Groups can be printed out either (on the default printer) or exported into CSV (comma separated) format files.

### Operational Procedure

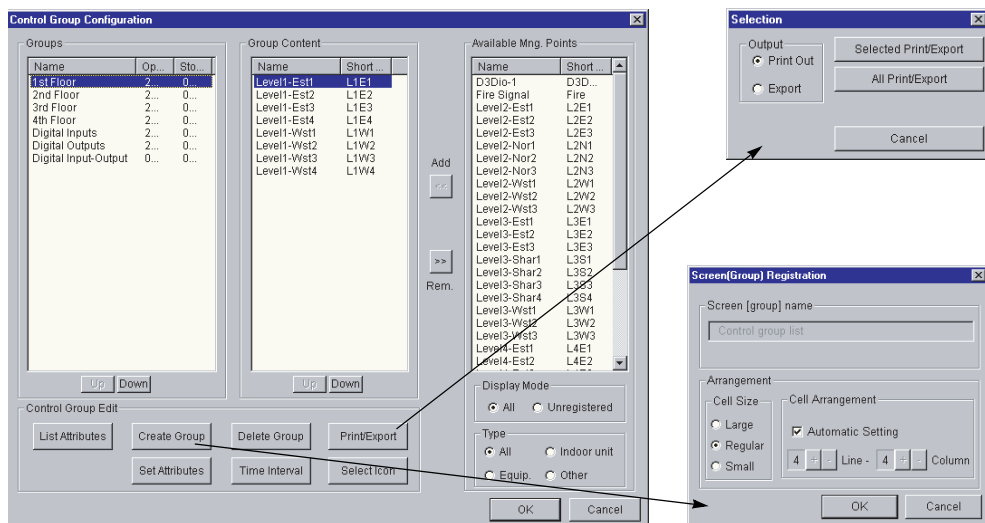

Default attributes of new groups can be preset as shown above.

Click on the **Create Group** button to display the group screen registration dialog box.

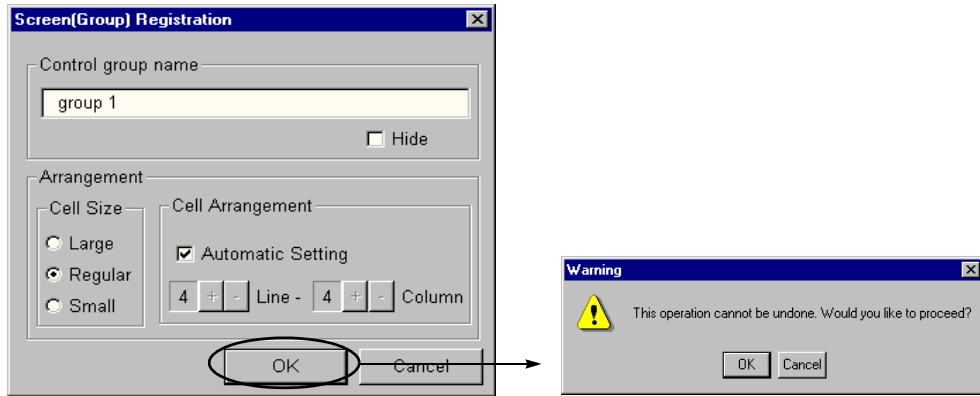

Enter the group name and click the **OK** button.

A warning box will appear at the time of the first operation.

Click the **OK** button to proceed with the operation or the **Cancel** button to cancel it.

The control group will then be displayed in the control group structure.

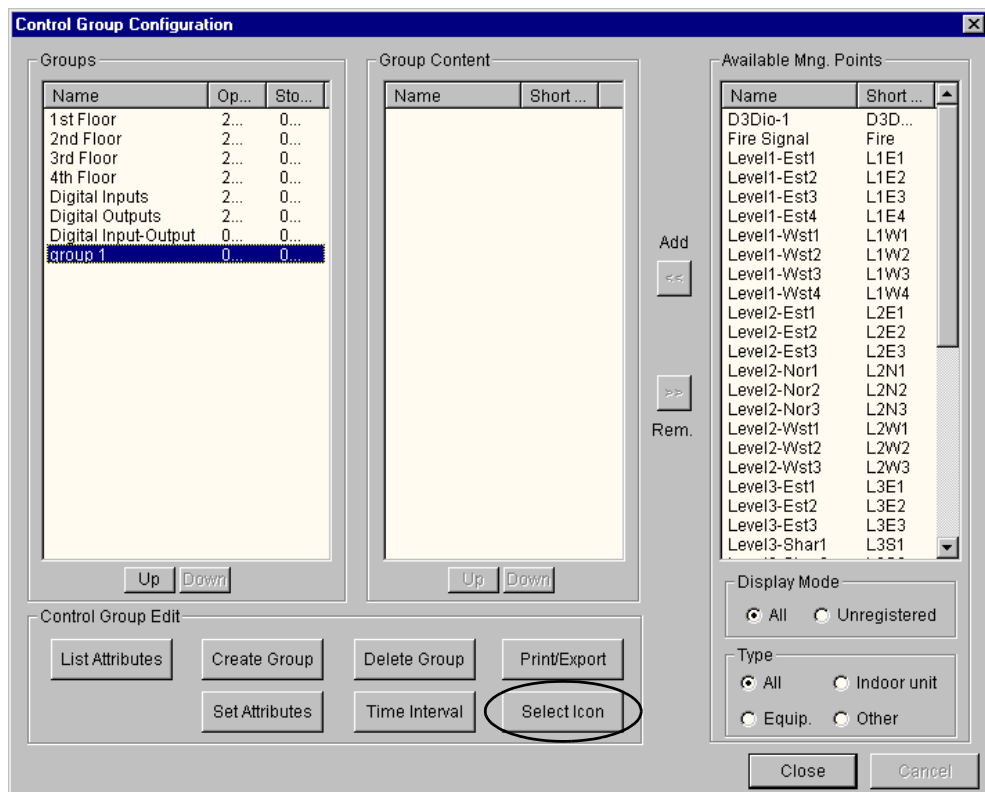

Select the group from the control group structure and click the **Select Icon** button to select the icon.

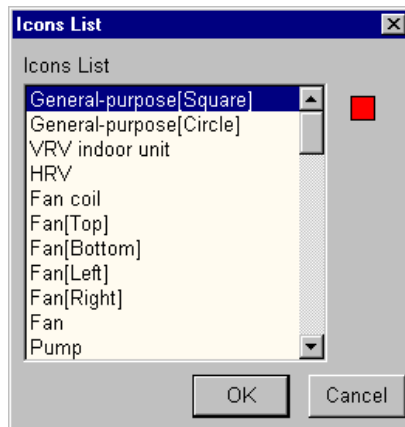

The management points belonging to this group are selected from the list of available management points and added by clicking the **Add <<** button. To remove a management point, select the management point to be removed from the management group content list and click the **Remove >>** button.

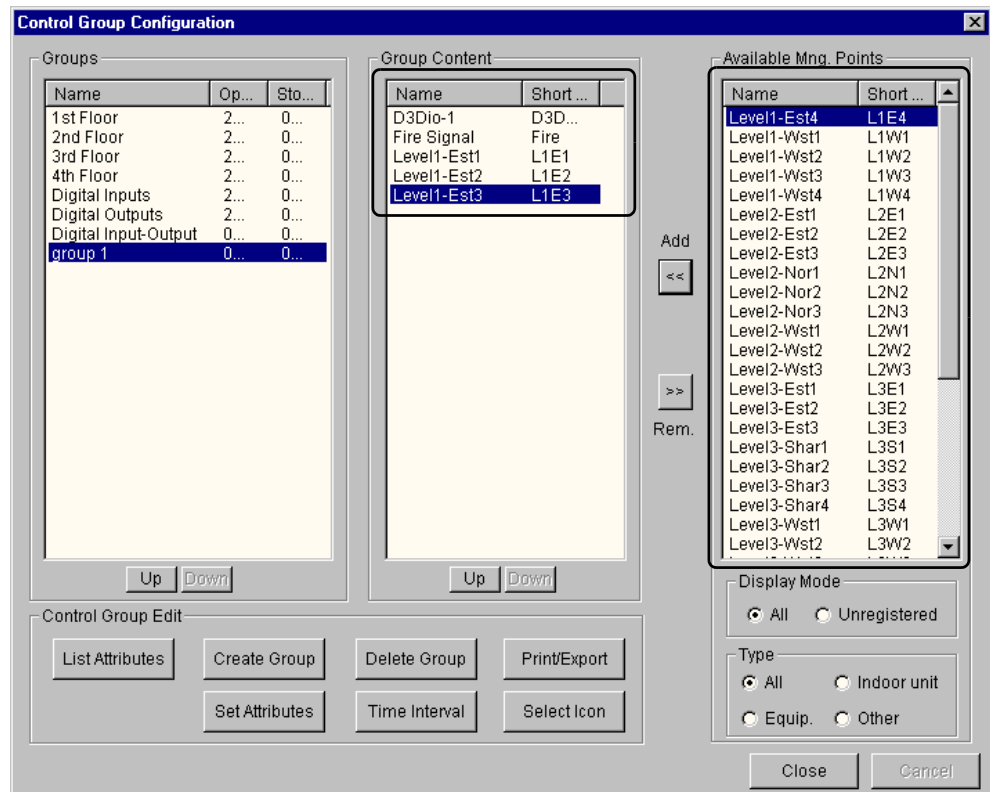

When a management point is registered, it will be displayed as in the screen above.

Sequential Start/Stop intervals may be set up for Start and Stop.

Select the group to be set up and click the **Time Interval** button to display a dialog box. Then set the sequential Start/Stop intervals.

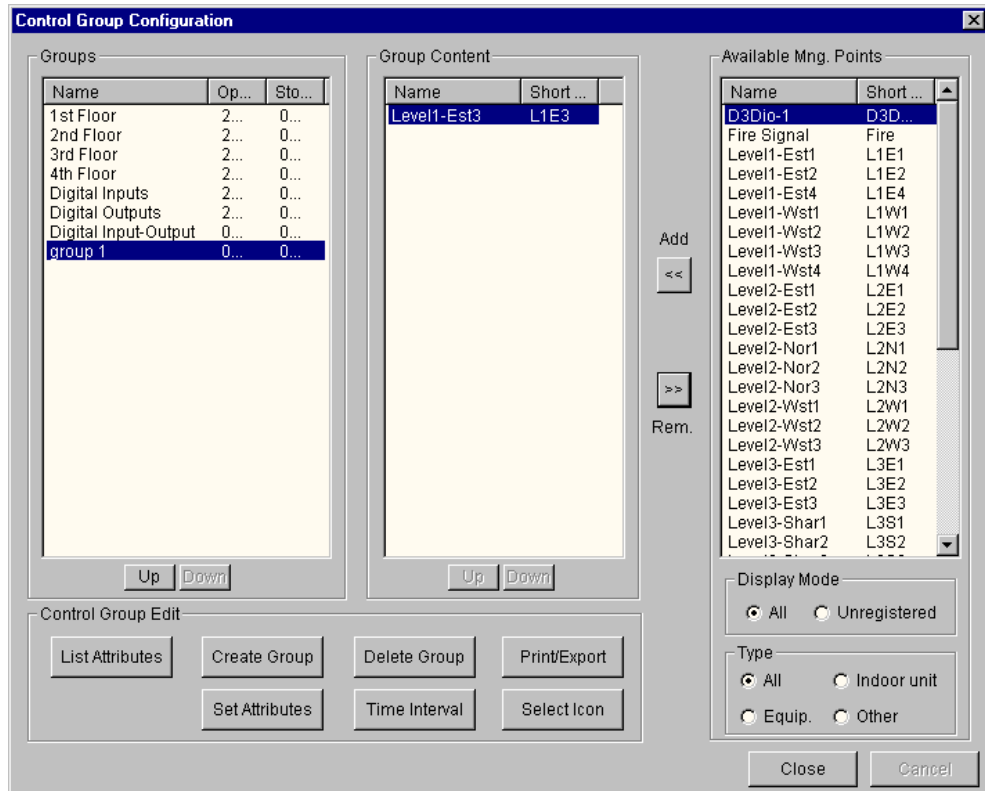

When all registrations have been completed, click the **Close** button.

Additionally, if a control group needs to be deleted, select the control group to be deleted and click the **Delete Group** button.

If a control group needs to be renamed, select the control group to be modified and click the **Set Attributes** button. A group registration dialog box will appear, thereby allowing name and arrangement specification to be modified.

### 5.7.3 Configuring user Login

#### 5.7.3.1 Fundamentals

A user's execution authority may be set up in order to restrict the range of operation and consultation.

**Note** Administrators only can perform this procedure. An administrator is an operator whose profile includes authorization to Register Users.

### User Management

- By logging in, a user may operate within the range of authority granted to him.
- A single user may not log in simultaneously from more than one connected monitoring PC.
- The items for which authority can be set up are shown as follows.

Authority	If authority is granted	If authority is not granted
<b>Start/Stop Setup</b>	Start/Stop/Setup operation is possible	Start/Stop/Setup operation is not possible
<b>Schedule Registration</b>	Consultation and registration/editing of schedule is possible	Schedule consultation only is possible
<b>Interlocking Control Registration</b>	Consultation and registration/editing of interlocking control is possible	Interlocking control consultation only is possible
<b>Emergency Stop Registration</b>	Consultation and registration/editing of emergency stop is possible	Emergency stop consultation only is possible
<b>Emergency Stop Release</b>	Forced release of emergency stop is possible	Operation cannot be performed
<b>History Operation</b>	Consultation and setup of history is possible	History consultation only is possible
<b>System Setup</b>	System setup is possible	Operation cannot be performed
<b>Centralized Control Setup</b>	Centralized control setup is possible	Operation cannot be performed
<b>User Registration</b>	User registration and authority may be set up	Operation cannot be performed
<b>Under Maintenance Mode</b>	Under maintenance mode may be set up	Operation cannot be performed
<b>Register Power Limit</b>	Consultation and editing of Power Limit parameters is possible	Power Limit consultation only is possible
<b>Register Eco Mode</b>	Consultation and editing of Eco Mode parameters is possible	Eco Mode consultation only is possible

### Screen Authority

It is possible to set up an authority able to open all screens or an authority able to open only those screens as specified in the screen registration.

---

Even if a screen may be opened, if the operation authority for that screen has not been granted, the authority takes precedence and operation will not be possible.

---



**Operational Procedure**

- Start intelligent Manager, then login as an administrator user,
- Click the **System** menu button; the **System Setup** screen displays,
- Click the **Set Login** button; the **Login Setup** screen displays,
- The list of users already registered is displayed as in the figure below,
- Perform as explained hereafter.

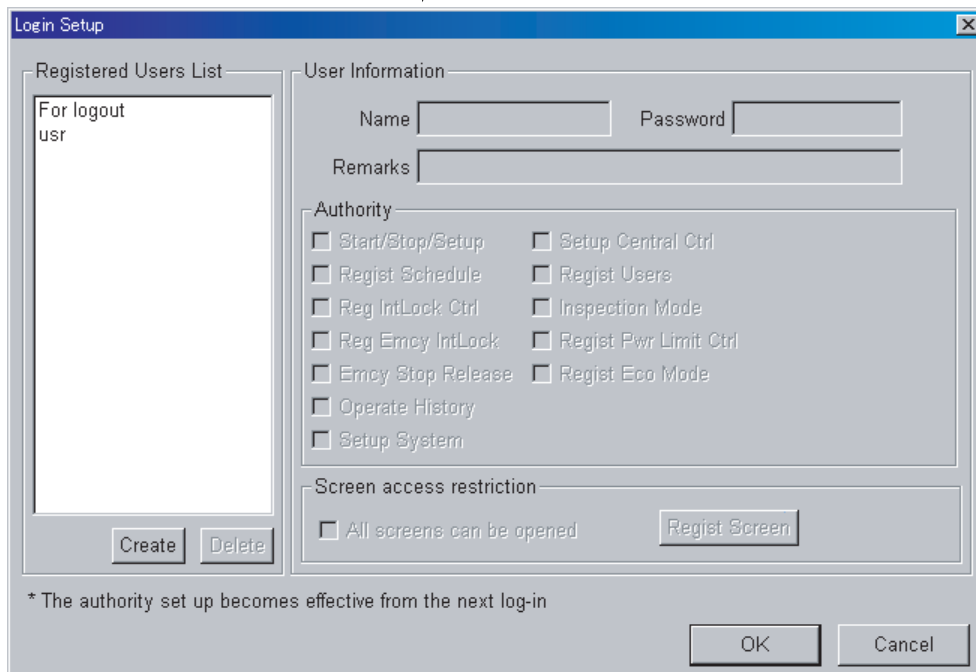
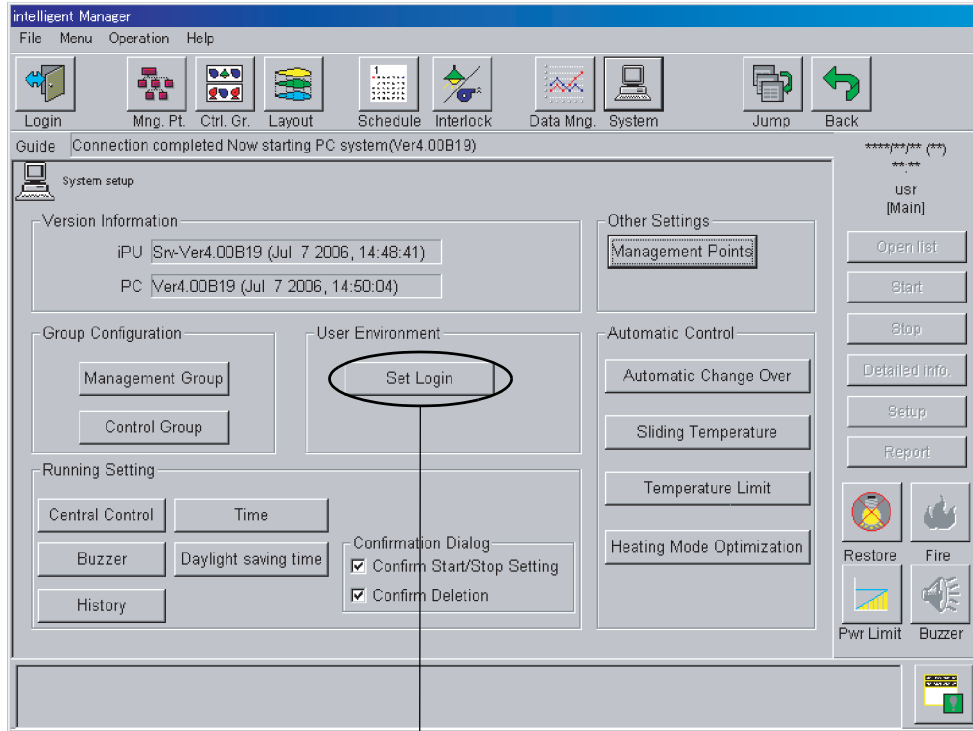

### 5.7.3.2 Creating a user

Click on the **Create** button to register a new user.  
It is allowed to prepare 255 users at the maximum.

The screenshot shows the 'Login Setup' dialog box. On the left, the 'Registered Users List' contains 'For logout' and 'usr'. The 'Create' button is circled in red. The 'User Information' section on the right has 'Name' set to 'Logoff' and 'Password' as an empty field. The 'Authority' section has several checkboxes, with 'Start/Stop/Setup' and 'Operate History' checked. The 'Screen access restriction' section has 'All screens can be opened' checked. At the bottom, there are 'OK' and 'Cancel' buttons.

The screenshot shows the 'Login Setup' dialog box after a new user has been created. The 'Registered Users List' now includes 'For logout', 'usr', and 'new01'. The 'Create' button is no longer circled. The 'User Information' section has 'Name' set to 'new01' and 'Password' as an empty field. The 'Authority' section has all checkboxes unchecked. The 'Screen access restriction' section has 'All screens can be opened' unchecked. At the bottom, there are 'OK' and 'Cancel' buttons.

Once a new user has been registered, the user name, password, remarks, authority and screen restrictions may be set up.

Enter the user name and password.

Check the check boxes to indicate those items for which authority setup will be granted.

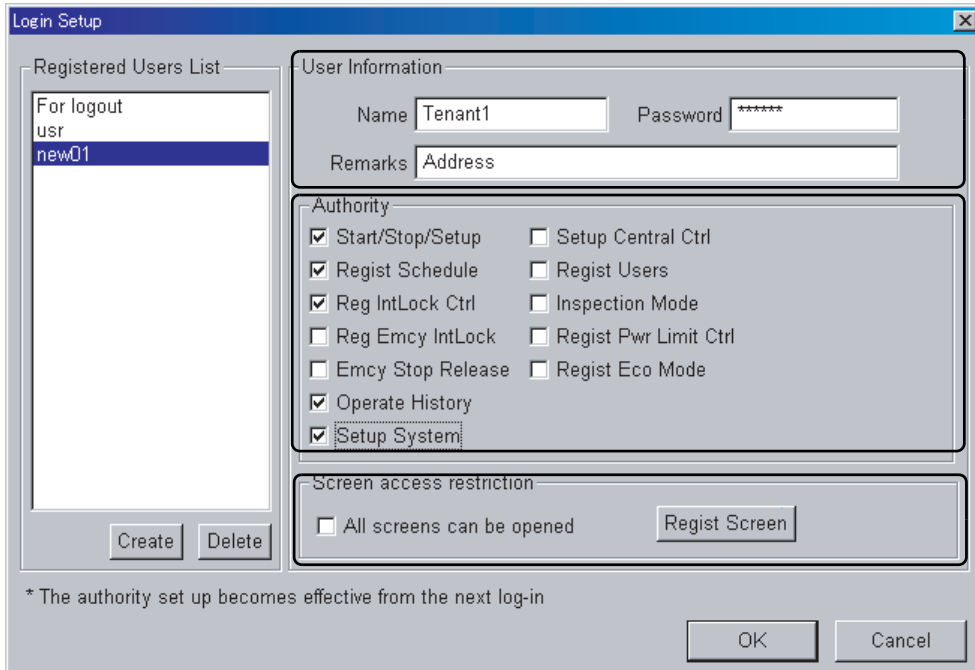

If the user is to be granted the authority to open all screens, check the appropriate checkbox.

If the screens that may be opened are to be restricted, click the **Regist Screen** button to display the screen selection dialog box.

The screens that may be opened are selected from the list of available screens and added by clicking the **Add >>** button.

To remove a screen, select the screen to be removed from the screen selection list and click the **Remove <<** button.

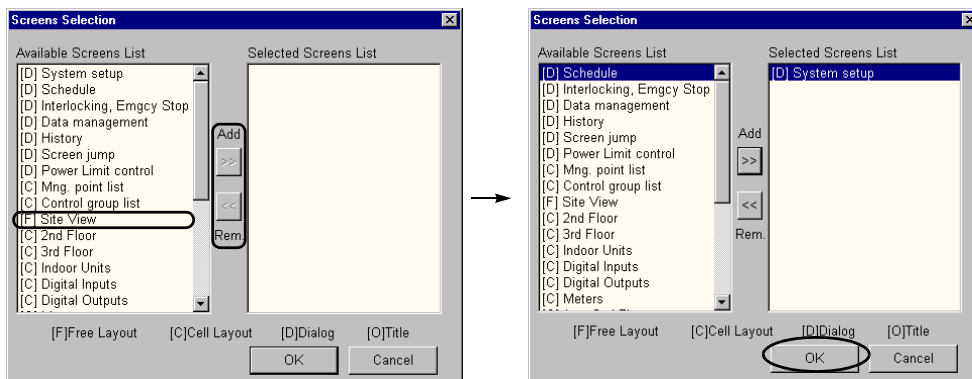

Click the **OK** button when selection is completed.

When all registrations have been completed, click the **OK** button.

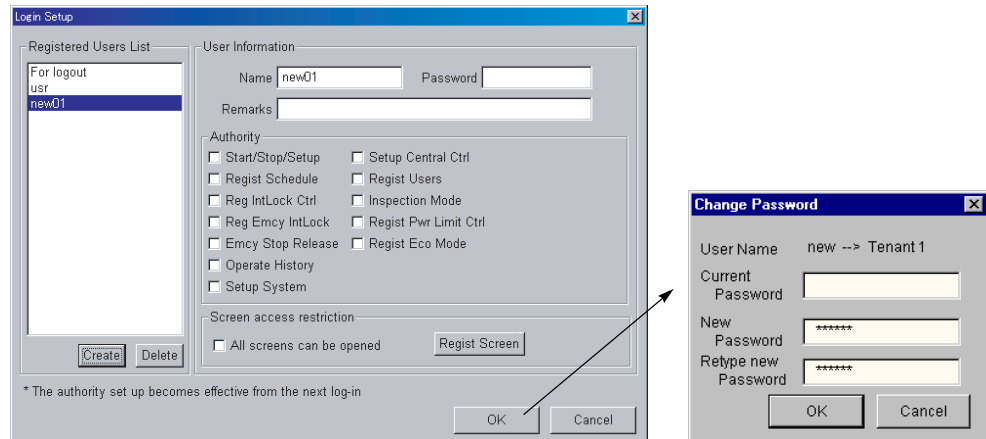

If the **Set Login** button from the **System Setup** menu is clicked again, the user will be seen to have been added as shown in the above figure.

- (1) Click the **Create** button; the fields for input enable.
- (2) Input the profile of the user:
  - Name: as used for Login,
  - Password: idem,
  - Remarks: freely describes the profile of the user,
  - Authority: check the boxes for the operation which this user can perform,
  - Screen Access:
  - Check the **All Screens** box
 or
  - Click the **Regist Screen** button; the **Screen Selection** screen appears, then:
    - Select the screens which you want the user to have access to from the left side list and click the **Add** button,
    - Select the screens which you want the user NOT to have access to from the right side list and click the **Remove** button,
    - Click the **OK** button; the Screen Selection screen closes,
    - Click the **OK** button will display the **Password** confirmation screen:
    - Enter the **Current** password and the **New** password (twice),
    - Click the **OK** button to confirm.

#### 5.7.3.3 Modifying a user

- (1) Select a user from the list; the fields for input enable.
- (2) Perform input as above step (2).

#### 5.7.3.4 Deleting a user

- (1) Select a user from the list; the confirmation dialogue box appears.
- (2) Click the **Yes** button.

Click the **OK** button; the **Login Setup** screen closes. The modifications are immediately effective.

### 5.7.4 Editing Management Points

It is possible to modify the following information contained within a management point.

- Name of management point.
- Short name of management point.
- Setup of maximum values of operation time and number of Start/Stop.

System setup authority is required for operation.

#### Operational Procedure

Select the management point whose information needs to be modified and click the **Attribute** to group to display the management point attribute modification dialog box.

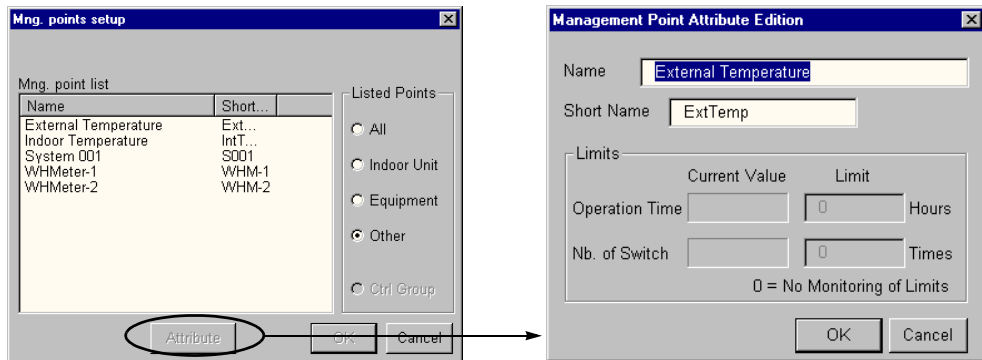

Modify the name, short name and maximum values as required. Click **OK** to return to the management point setup dialog box.

---

If the cumulative maximum value is set to 0, it may not be possible to monitor maximum values.

---

When all modifications have been completed, click the **OK** button of the dialogue box for the management point setup.

### 5.7.5 Setting up Central control

It is possible to set centralized control for permission/prohibition for every DIII-net port.

Central control permission/prohibition is used to indicate whether or not permission is to be granted for an operation from a connected Daikin centralized control unit (for example: remote controller etc.).

System setup authority is required to operate it.

## Operational Procedure

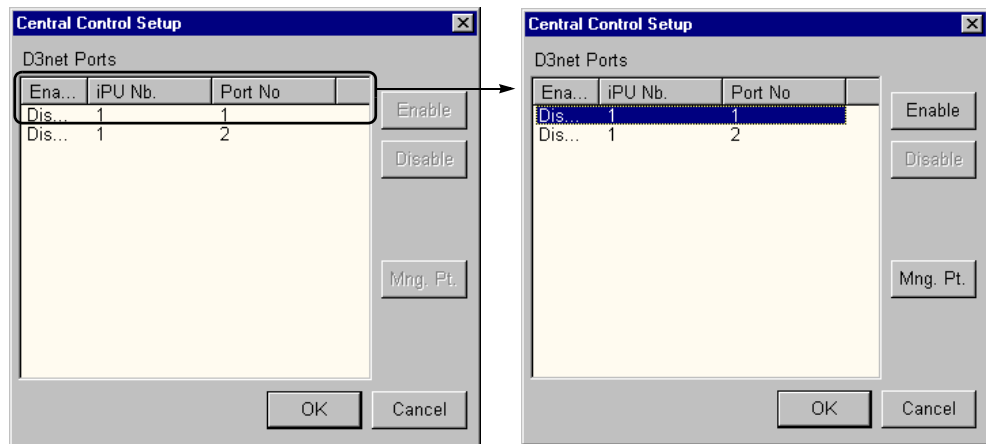

The state of permission or prohibition of the Station numbers and Port numbers connected to the main system is displayed.

Permission/prohibition is used to define whether or not permission is to be granted for an operation from a connected Daikin centralized control unit.

If permission is granted for the Start/Stop operation, priority will be given to other Daikin central control units. If permission is denied, operation will only be possible from intelligent Manager.

Select the line of the Station and port number to be modified.

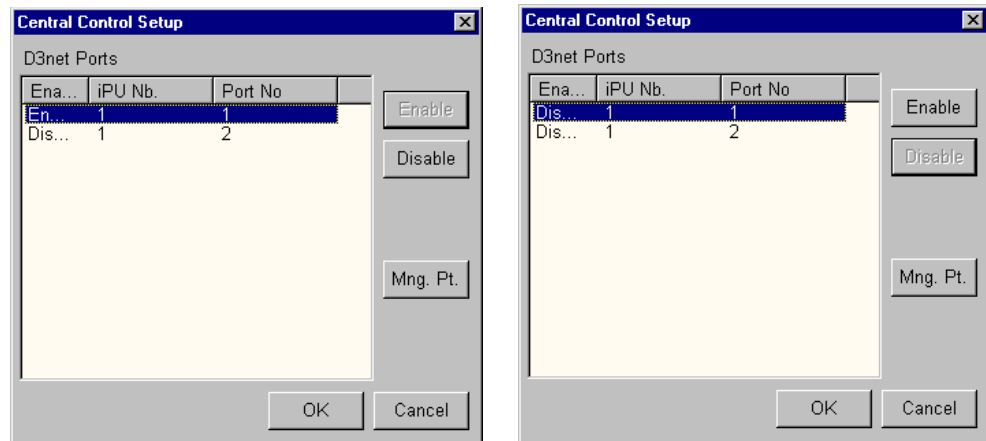

The selected line is displayed in reverse field and the button showing the reverse of the current state is displayed. (If permission has been granted for the current state, the **Disable** button will be enabled and vice-versa the **Enable** button will be enabled if permission has been denied).

In the screen above click the **Enable** button.

The state of Port 1 has been modified to prohibition.

To display the management points, select the Port number to be displayed and click the **Management Points** button to display a dialog box.

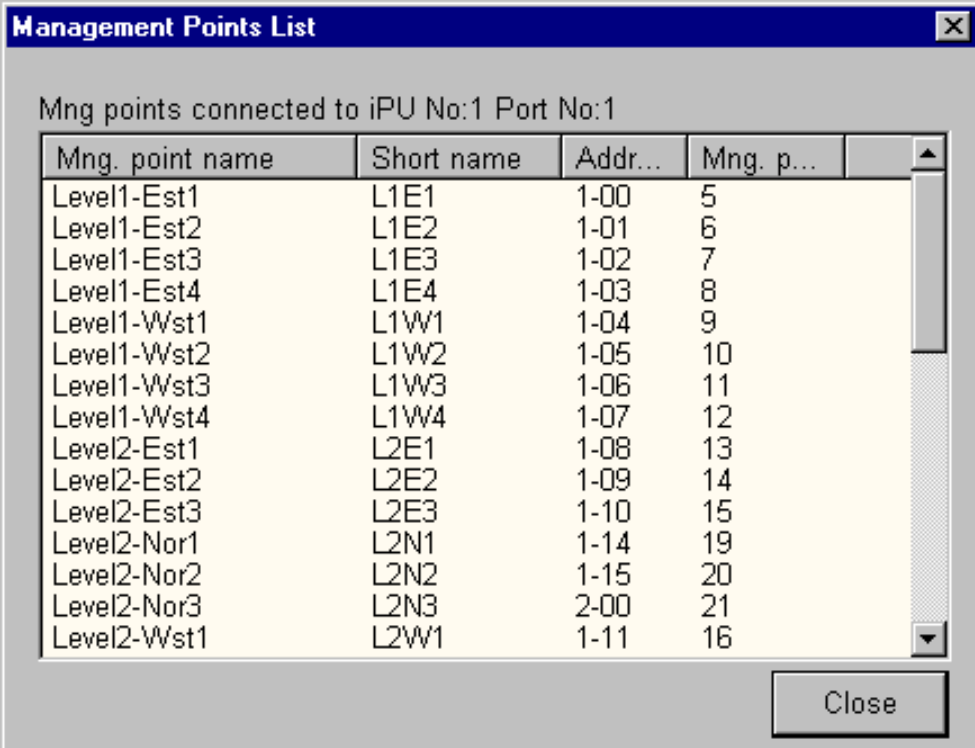

The image shows a dialog box titled "Management Points List" with a close button in the top right corner. Below the title bar, it says "Mng points connected to iPU No:1 Port No:1". The main area contains a table with four columns: "Mng. point name", "Short name", "Addr...", and "Mng. p...". The table lists 16 management points, grouped into Level 1 and Level 2. A "Close" button is located at the bottom right of the dialog box.

Mng. point name	Short name	Addr...	Mng. p...
Level1-Est1	L1E1	1-00	5
Level1-Est2	L1E2	1-01	6
Level1-Est3	L1E3	1-02	7
Level1-Est4	L1E4	1-03	8
Level1-Wst1	L1W1	1-04	9
Level1-Wst2	L1W2	1-05	10
Level1-Wst3	L1W3	1-06	11
Level1-Wst4	L1W4	1-07	12
Level2-Est1	L2E1	1-08	13
Level2-Est2	L2E2	1-09	14
Level2-Est3	L2E3	1-10	15
Level2-Nor1	L2N1	1-14	19
Level2-Nor2	L2N2	1-15	20
Level2-Nor3	L2N3	2-00	21
Level2-Wst1	L2W1	1-11	16

#### 5.7.6 Configuring the Buzzers

- Buzzers may be assigned as required to various types of alarm.
- Four types of sound are available for the alarm buzzer.
- It is possible to disable any particular buzzer.
- The duration of the buzzer sounding may be specified.
- The icon changes in accordance with the state of the buzzer.

- When the buzzer sounds, any screen saver in current operation is simultaneously stopped.
- System setup authority is required for the buzzer setup.

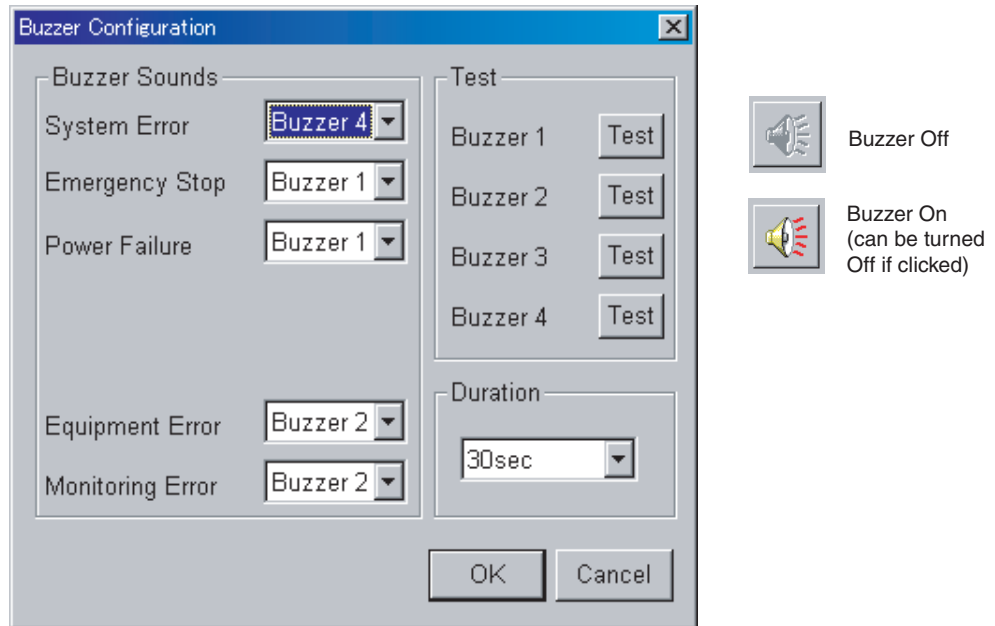

### 5.7.7 Configuring History options

The following history setups are possible, depending on data type:

- Display - Yes/No,
- Print by alarm printer - Yes/No,
- Save as File - Yes/No,

Keep history of a limited selection of Management points (default setting is all points)

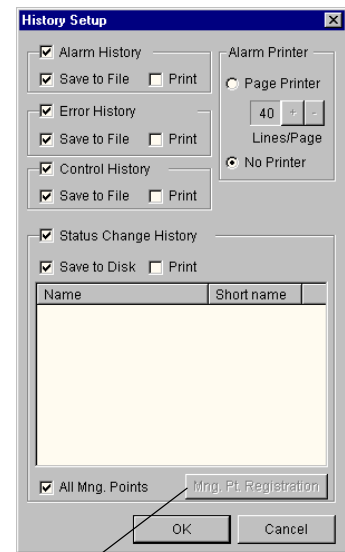
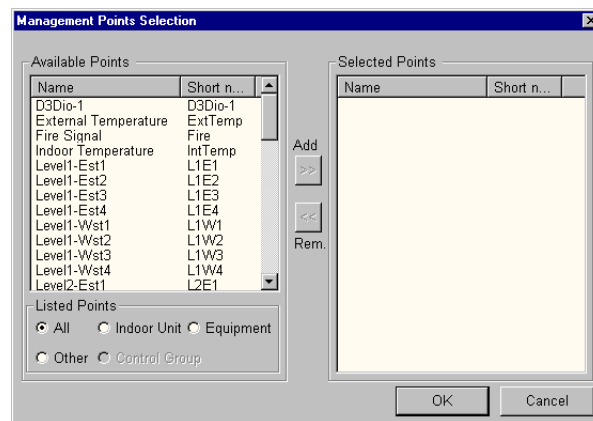

### 5.7.8 Adjusting the Time

- The Station clock is set to the PC (personal computer) time.
- The PC clock may be set to the Station time.
- System setup authority is required to set the PC clock.
- Time modifications should be avoided between 23:30 and 2:30 as the Station is engaged in data management.



### Modifying Station time

When time is put forward, scheduled operations for the intervening period are skipped.

When time is put back, control that has already been executed is repeated and the data collected before the modification is updated and managed.

When time is to be modified, the Station time setup is performed once the programs of running control etc. have been deactivated.

### Data management setup (in particular billing-related matters) should be completed before time modifications are made.

Major time modifications should be avoided. (This can lead to inaccuracies in billing management data, daily report data etc.).

---

To ensure accurate monitoring, time should be correctly adjusted on a monthly basis (particularly in the case of billing management).

---

### Operational Procedure

Click the **Setup** button to select method of time setup.

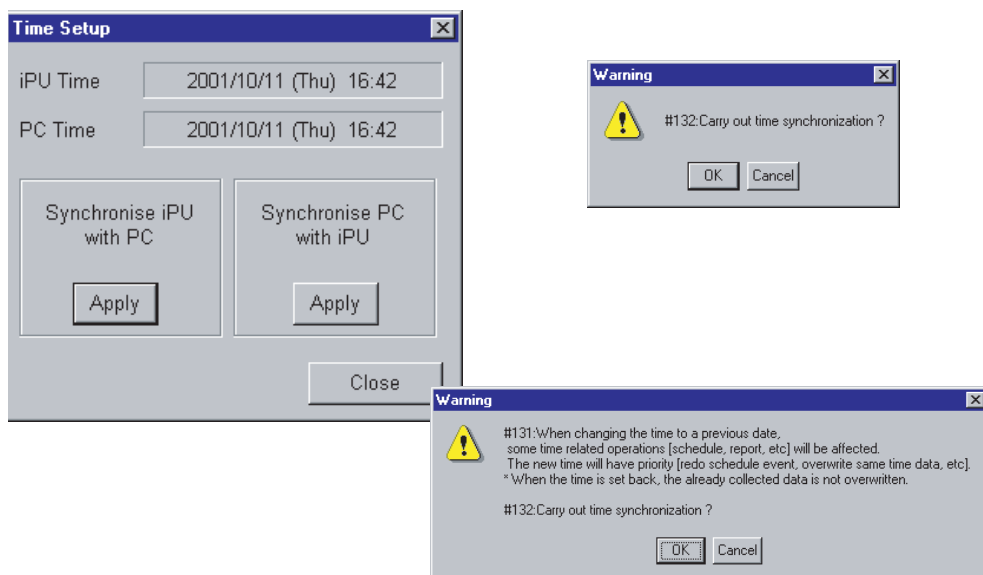

### 5.7.9 Enabling Confirmation Dialog

---

Serves to confirm the execution or cancellation of an operation (Start, Stop, Setup).

---

### Operational Procedure

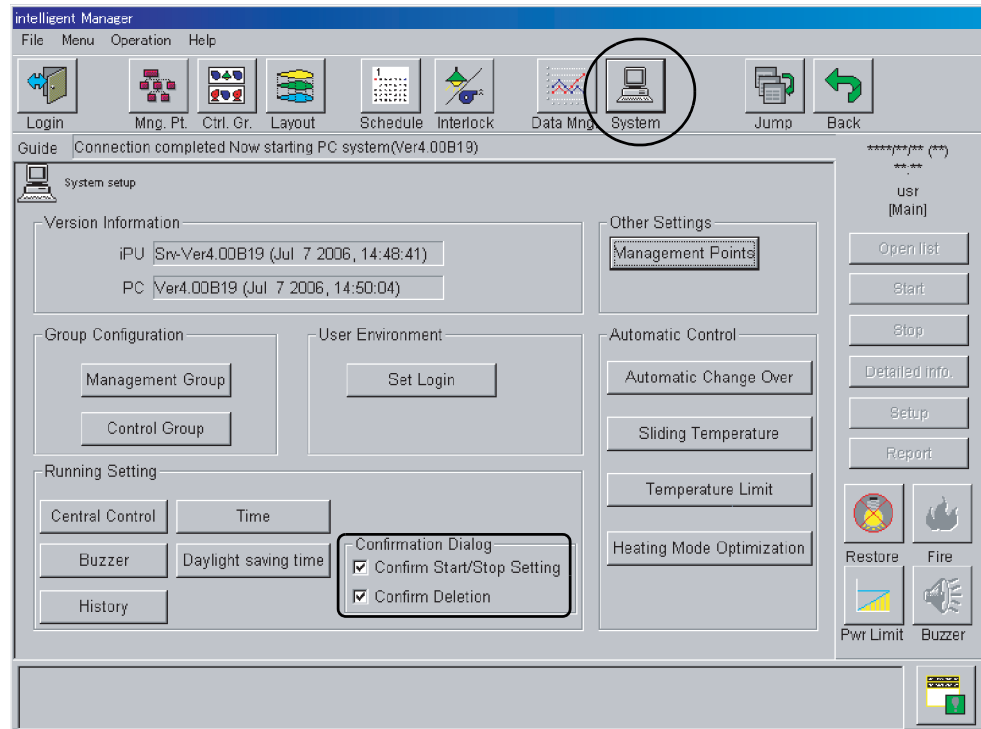

Check the appropriate "Confirmation dialog - yes/no" checkbox to make use of the confirmation dialog as required.

Check the checkbox to enable the dialog - leave the checkbox blank to disable the dialog.

#### 5.7.10 Setting up the Daylight saving time

Serves to configure the date and time for the shift when daylight saving time is used (summer time).

### Operational Procedure

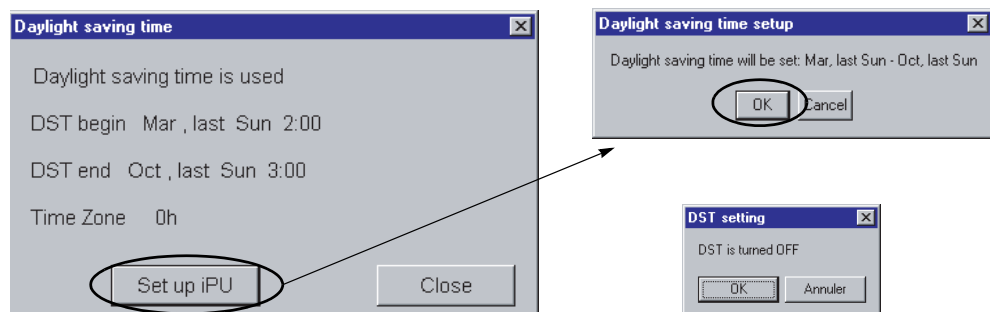

### 5.7.11 Automatic Change Over

Serves to configure the function that change the operation mode of a group of indoor units according to the room temperature as shown on the figure below.

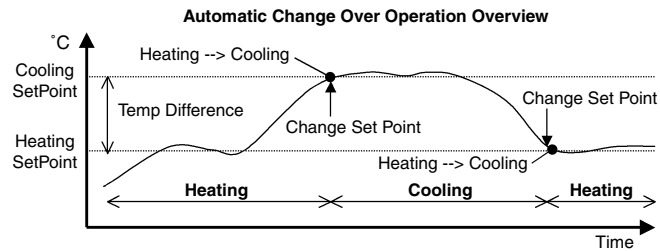

#### Operational Procedure

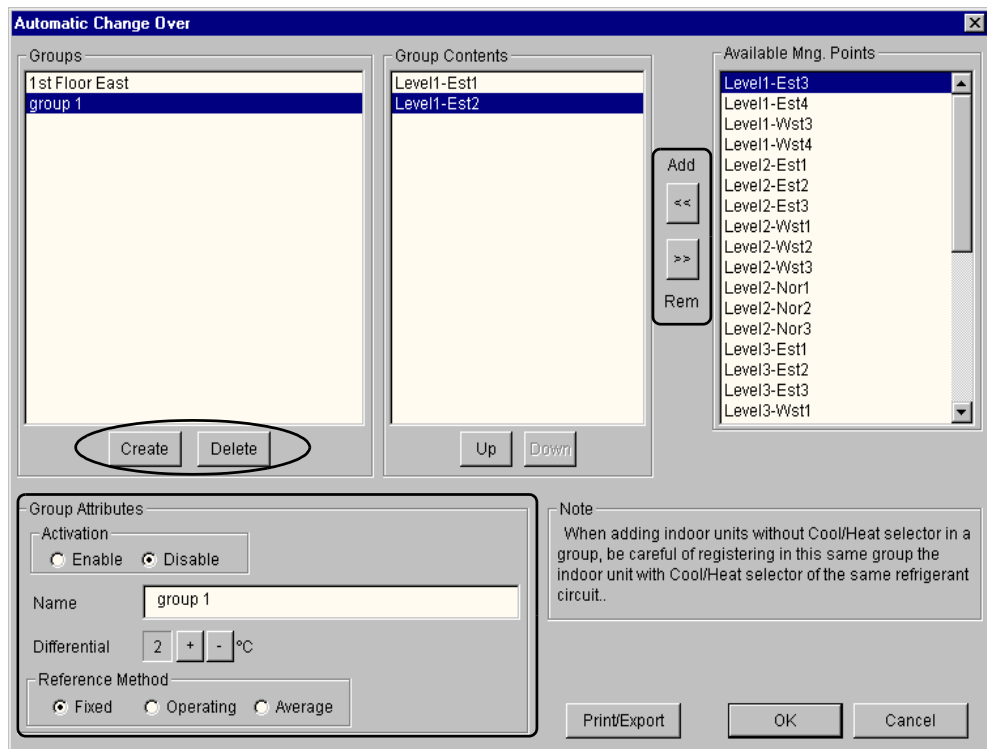

- Create the group;
- Enter the group name;
- Add/Remove indoor unit members of the group (with the referential one at first);
- Select the selection method between:
  - Fixed (the first indoor unit of the group);
  - Running (the first indoor unit in operation of the group);
  - Average (average value of all indoor units of the group).
- Enter the Differential temperature (between Cooling and Heating Set Point);
- Enable the group.

Click on the **Print/Export** button to print all groups settings on the system printer or to save them in a CSV (comma separated) format file.

**Note** Up to 512 groups can be created for this function, each group registering up to 128 management points.

**Important** In order to ensure a correct operation always register in a same group the "slave" indoor units (i.e. without Cool/Heat Selector) with the "master" indoor unit (i.e. with Cool/Heat Selector) of the same refrigeration circuit. Always register the "slave" indoor units after the "master" indoor units, because the selection method (Operating) is performed in order of the group list.

### 5.7.12 Sliding Temperature

Serves to configure the function that change the Cooling Set Temperature of a group of indoor units according to the outdoor temperature as shown on the figure below.

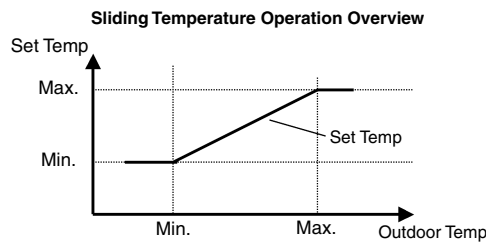

**Note** This function requires a separate sensor for the outdoor temperature.

### Operational Procedure

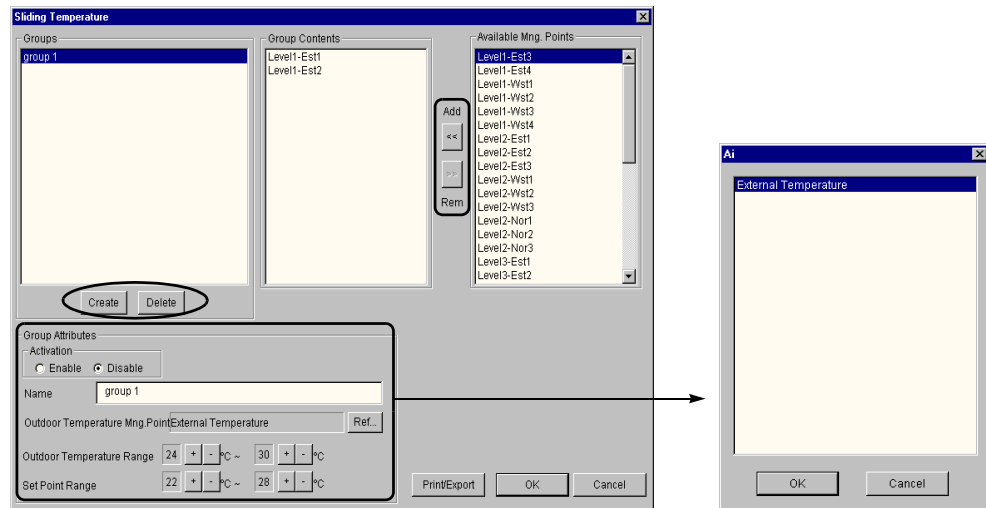

- Create the group;
- Enter the group name;
- Add/Remove indoor unit members of the group;
- Select the outdoor temperature management point (Ai);
- Select the min and max for:
  - Outdoor temperature;

- Set Temperature;
- Enable the group.

Click on the **Print/Export** button to print all groups settings on the system printer or to save them in a CSV (comma separated) format file.

**Note** Up to 8 groups can be created for this function, each group registering up to 128 management points.

### 5.7.13 Temperature Limit

Serves to configure the function that starts automatically (and individually) the indoor units in heating mode (when the temperature is too low) or in cooling mode (when the temperature is too high) as shown on the figure below.

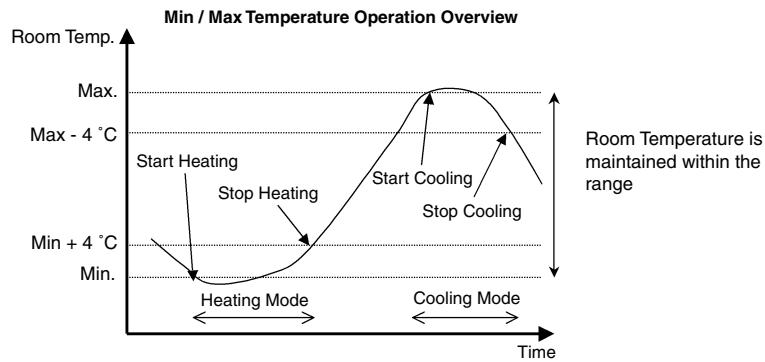

### Operational Procedure

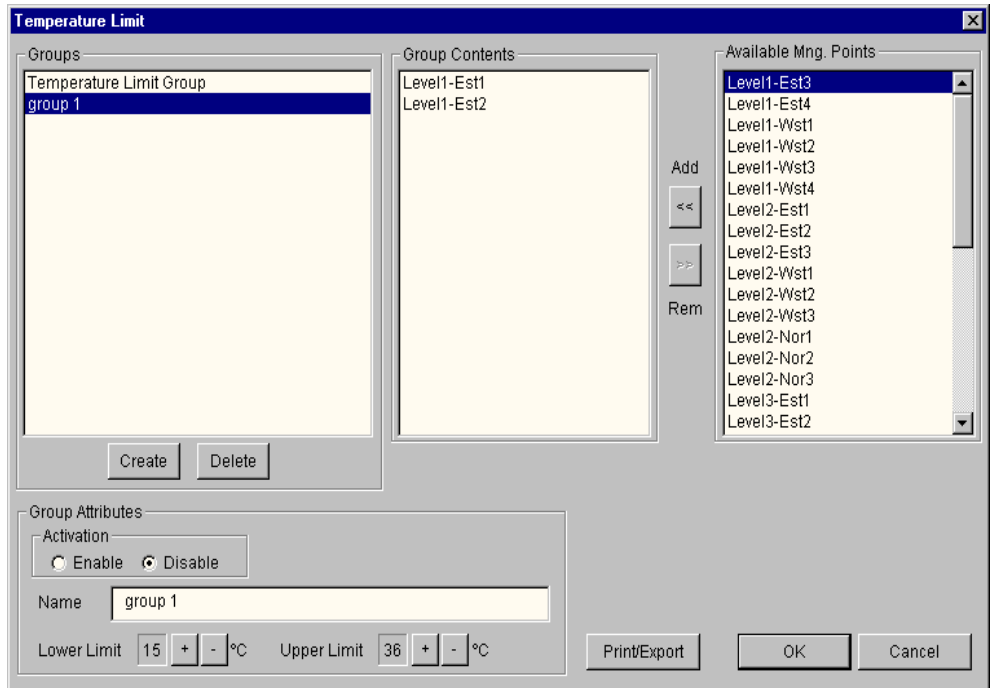

- Create the group,
- Enter the group name,
- Add/Remove indoor unit members of the group,

- Select the min and max Room temperature,
- Enable the group.

Click on the **Print/Export** button to print all groups settings on the system printer or to save them in a CSV (comma separated) format file.

**Note** Up to 8 groups can be created for this function, each group registering up to 128 management points.

**Important** In order to ensure a correct operation always register in a same group the "slave" indoor units (i.e. without Cool/Heat Selector) with the "master" indoor unit (i.e. with Cool/Heat Selector) of the same refrigeration circuit. Always register the "slave" indoor units after the "master" indoor units, because the selection method (Operating) is performed in order of the group list.

### 5.7.14 Heating Mode Optimization

Heating Mode Optimization (HMO) function stops the indoor unit in order to suppress wasteful rise of room temperature during heating operation (energy saving) and to suppress uncomfortable draft. While HMO is being operated, the remote controller is held to the stop state but on the intelligent-Manager, the unit looks like running. In the event that room temperature drops from the temperature setting, the unit automatically resumes heating operation. This function is activated during heating only. However, this is not activated in the automatic heating mode.

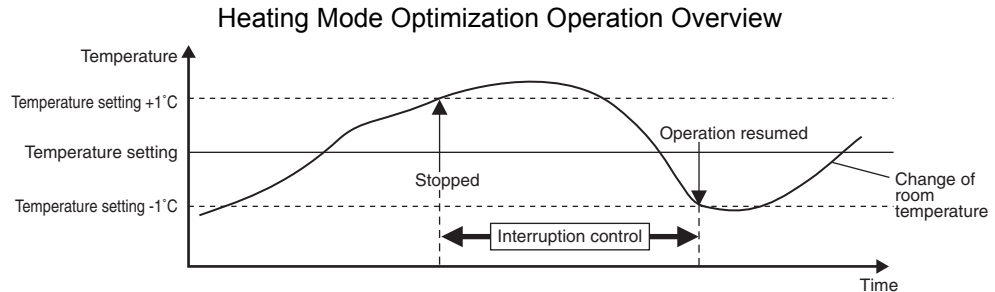

#### Operation Procedure

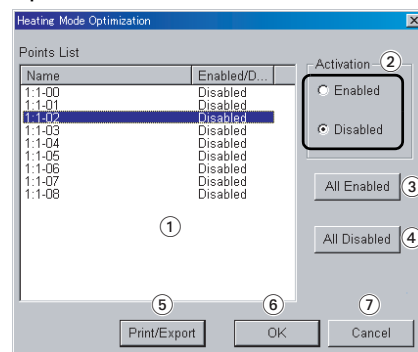

- Select indoor unit from the list.
  - With the Activation radio button, select Valid/Invalid.
- Pressing ALL Enable button enables HMO setting of all the indoor units in the list.  
 Pressing ALL Disable button disables HMO setting of all the indoor units in the list.

Click on the Print/Export button to print all setting on the system printer or to save them in a CSV (comma separated) format file.

**Note** In order to indicate indoor units on the list, setting by the management point setting tool is required.

### 5.8 Moving between Screens

It is possible to move between screens at will and there are two ways of doing so: 'simple movement' and 'movement by the reservation button'.

Moreover, if the automatic circular sequence function is used, multiple registered screens will be displayed and automatically switched over at a predetermined frequency.

Click the **Jump** button.

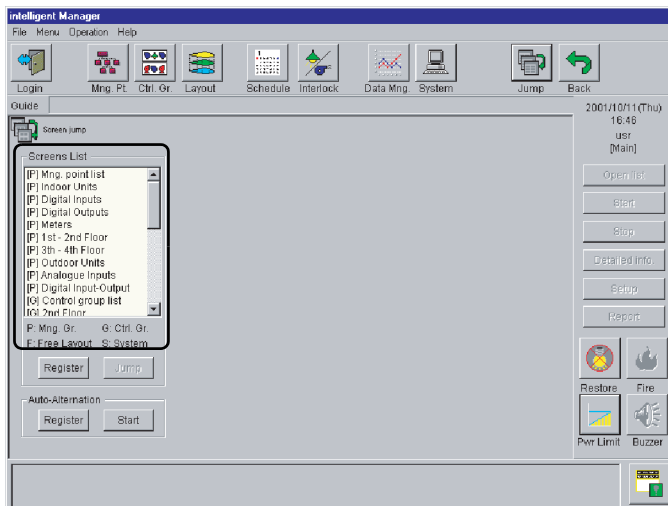
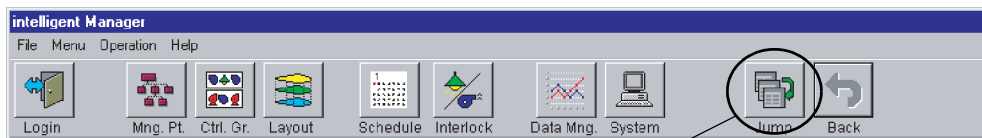

Types of screens that may be moved to:  
[P]: Screen of the management points of management groups  
[G]: Screen of the management points of control groups  
[S]: Screen related to the system

### 5.8.1 Simple Movement

A list of the screens that may be moved to is displayed. Select the screen to be moved to from the screen list and click on **Jump** button to move to this screen.

Screens to be moved to.

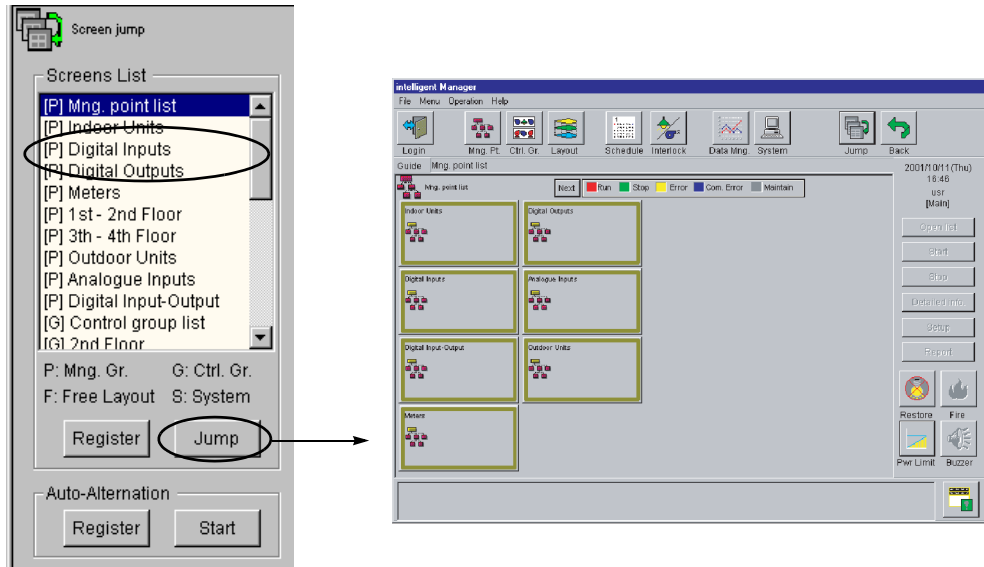

### 5.8.2 Movement by Reservation Button

Click the **Register** button to display the following dialog box.

Select the screen to be reserved from the screen list and click the **Add >>** button to register it in the list of reserved screens. To remove from the reserved area, click the **Remove <<** button.

Select the order of the buttons: select the button screen from the reserved screen list and click the **Up** button to move the button to the top. To move the button to the bottom, click the **Down** button.

Finally click the **OK** button.

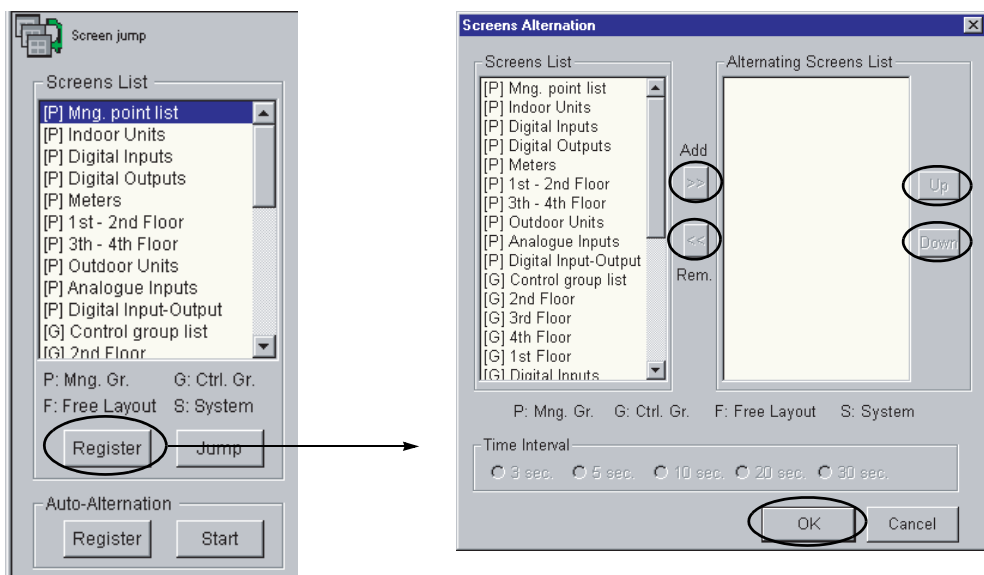



The buttons are generated.  
 Click the respective button to jump to the corresponding screen.

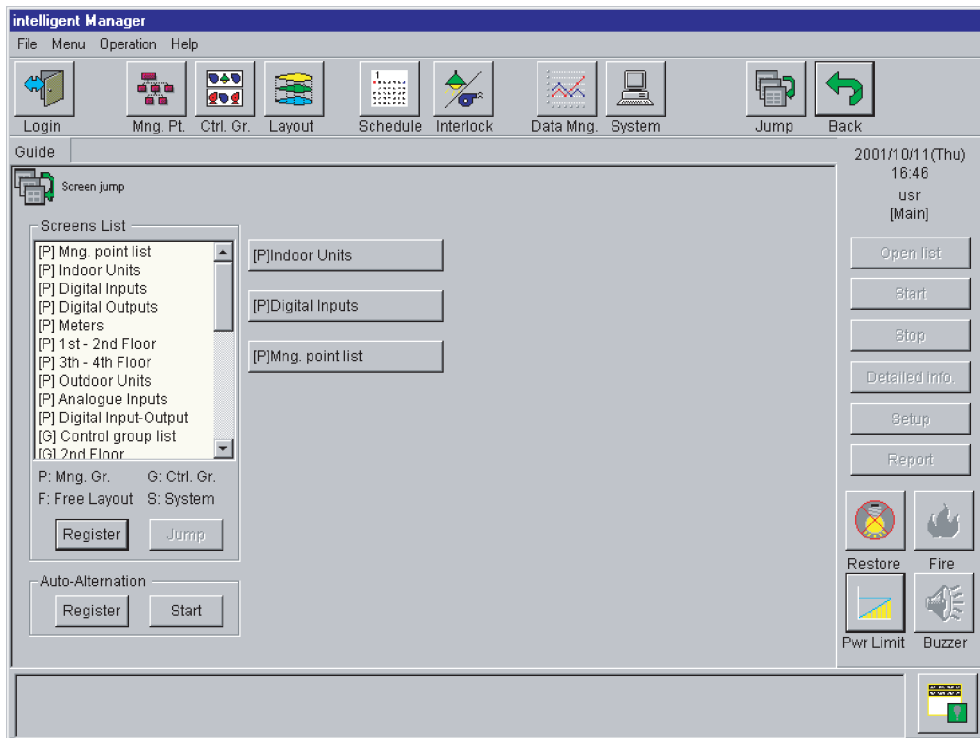

### 5.8.3 Automatic Circular Sequence

Pre-registered multiple screens may be displayed and made to switch over at a pre-determined frequency.

Click the **Register** button to display the following dialog.

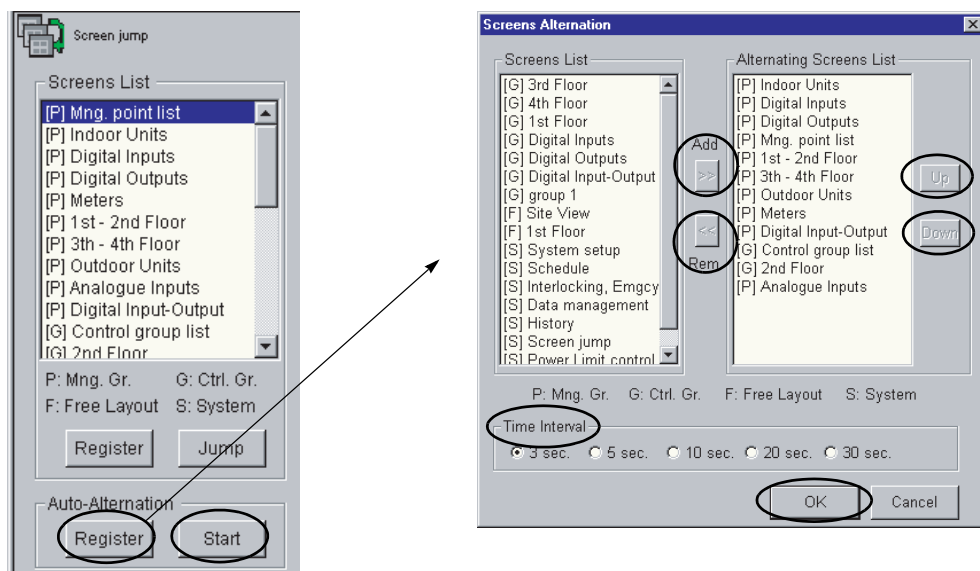

Select the screen to be reserved from the screen list and click the **Add >>** button to register it in the list of reserved screens. To remove from the registered area, click the **Remove <<** button.

Select the screen **Switchover Time Interval** from the radio buttons.

Finally click the **OK** button.

Click the **Start** button to activate the automatic circulation of screens in their registered sequence.

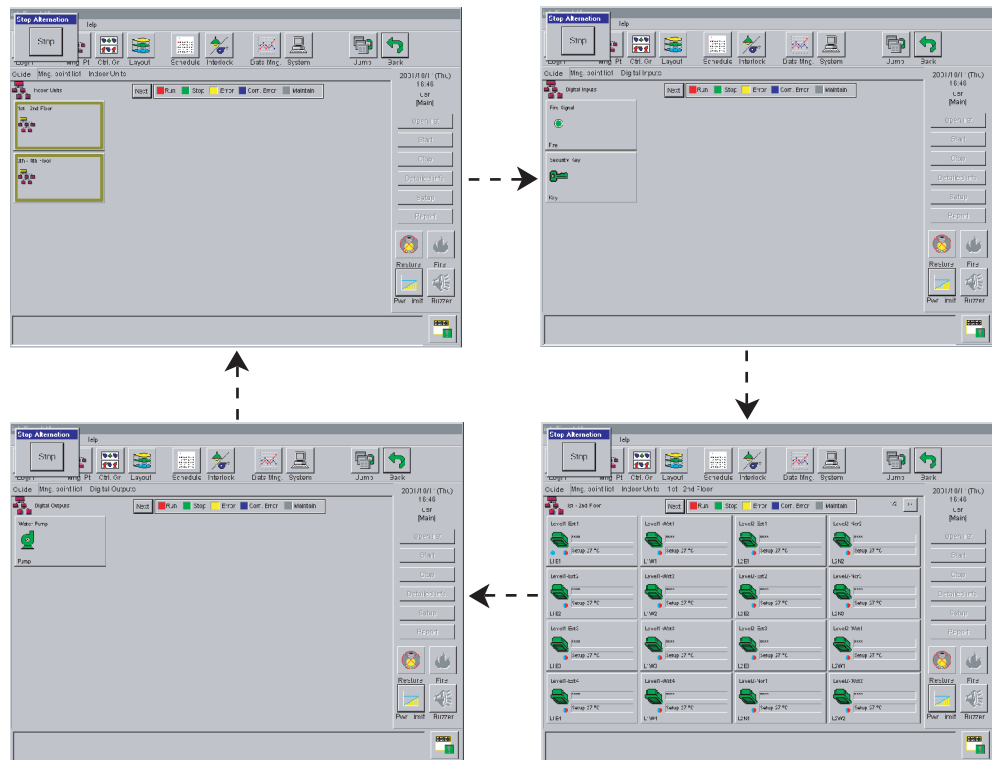

Click the **Stop** button to stop the automatic circular sequence.

## 5.9 Malfunction Display and History Management

If the monitored equipment malfunctions, details of the content will be displayed in the **[Malfunction history real-time display area]** at the bottom of the screen. At the same time, in accordance with system settings, an alarm buzzer will sound.



After the equipment malfunction has been confirmed/ dealt with, the **[Detailed history screen]** is able to color-code and manage whether the confirmed malfunction has been acknowledged.

The 20 most recent cases of malfunction messages are displayed in the **[Malfunction history real-time display area]** and the 100 most recent cases of malfunction and change in Equipment State (such as Start/Stop) are displayed in the **[Detailed history screen]**.

Moreover, a direct switchover function makes it possible to jump to the **[Management point list screen]** on which the management point responsible for generating the error is displayed.

In addition to the above real-time data, data of the malfunctions and changes in state from over approximately the past one-year period can be saved separately in a file on the hard disk. This saved data may also be consulted on the **[Detailed history screen]**.

### 5.9.1 Displaying Malfunction Messages

If a malfunction or breakdown forecast is generated in the monitoring equipment, details of the content will be displayed in the **[Malfunction history real-time display area]** at the bottom of the screen. At the same time, if the alarm buzzer has been set to ON (set up on the system setup screen), an alarm buzzer will sound.

Above is an example extracted of the main screen. However, **[Malfunction history real-time display area]** can appear on any screen and if a malfunction or breakdown forecast is generated, details of the content will be displayed in this area.

### 5.9.2 Operator History Display Function

This is the function to store the additional information in the state change history, when an instruction (start/stop, temperature setting, and operation mode) to the management point is executed and the instruction state is changed by the monitor panel instruction.

The following two types of additional information are stored:

- Automatic control name  
When an instruction is automatically issued from iPU, the auto-control name is recorded in the state change history as the additional information.
- User name  
When an instruction is manually issued from iPU, the login user name and "from monitor panel" are recorded in the state change history as the additional information.  
When the user manually operates it without login, the login user name is recorded as "--" in the state change history.

The condition below determines whether the additional information for an instruction to the management point is recorded in the state change history.

1. When the state change coincides with the instruction or the instruction state change includes all the instruction, iPU is determined as an operator.
2. When the state change partly coincides with the instruction, iPU is determined as an operator.
3. When the state change totally differs from the instruction, the remote-controller or other centralized equipment is determined as an operator.  
(When multiple operations are issued from iPU, the latest instructed operation is determined as an operator.)

\* The additional information for an operation from the remote-controller or other centralized equipment is not recorded in the state change history.

As shown below, the additional information is displayed in the state change history in the history display screen of the monitor panel.

Operator	History display string ("****" stands for a state change string, USER stands for the user name)
Monitor panel	****(PC:USER)
WEB	****(WEB:USER)
Schedule	****(Schedule)
Optimal startup control	****(Optimum Startup)
Interlock control	****(Interlocking)
Emergency stop	****(Emg. Stop)
Goal electric power control	****(Power Limit Ctrl)
Energy saving control	****(Eco Mode)
Power outage/power recovery control	****(Power Status)
Automatic Change Over	****(ACO)
Heating Mode Optimization	****(HMO)
Timer Extension	****(Timer Exl.)
Temperature Limit	****(Temp. Limit)
Sliding Temperature	****(Sliding Temp.)

### 5.9.3 Detailed History Screen

In addition to malfunction of management points, changes in state (such as Start/ Stop) brought about by automatic control (scheduling etc.) may be managed on the detailed history screen.

Information displayed on the detailed history screen may be either real-time data or information saved in a file on the hard disk.

#### [Detailed History Screen (saved data)]

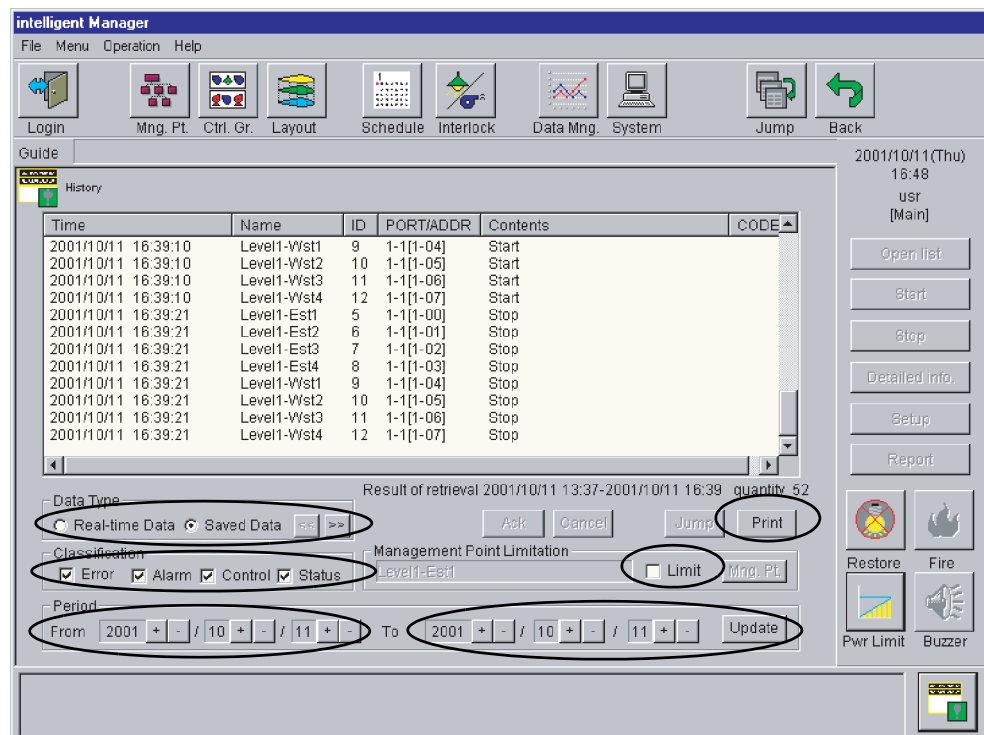

By means of the detailed history screen, it is possible to search and display selections from 100 items of real-time data and approximately 500,000 items of saved data.

It is possible to restrict the types of error and management points displayed in both real-time and saved data. Moreover, fixed term searches can be made in the case of saved data. 100 items of search results can be displayed on the screen at any one time and the search can be continued using Next >> and Previous <<.

Various setups are possible according to the type of data in the content of the history display. Please refer to **5.7.7 Configuring History options** (p. 91).

[Detailed History Screen (real time data)]

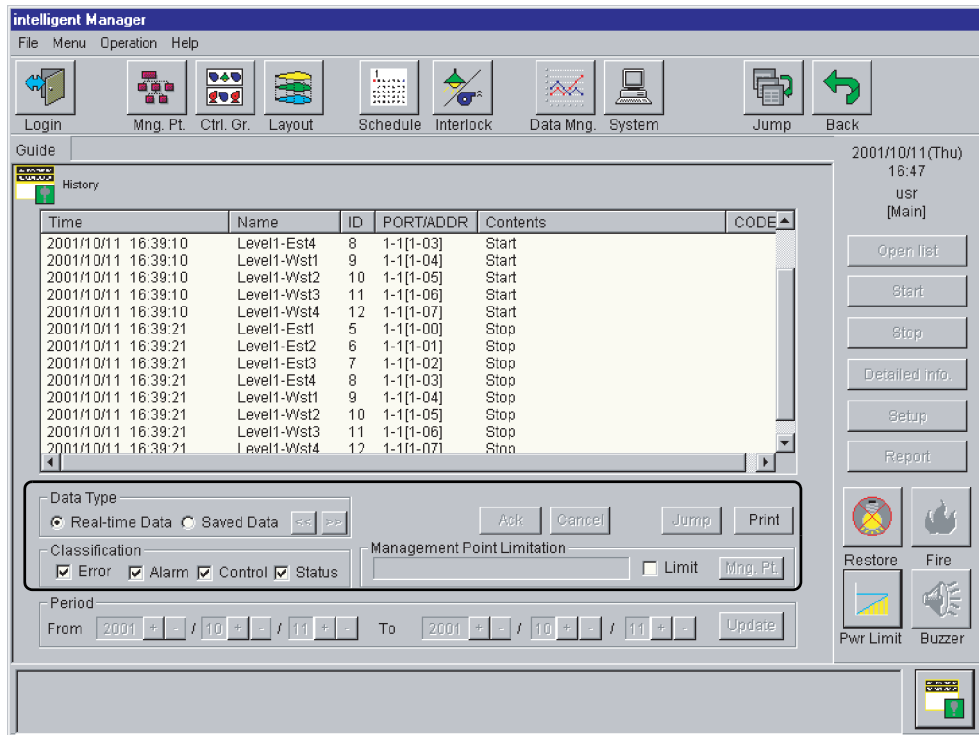

The color of the message display varies according to the type of history.

The color of a message that has been confirmed is indicated in brackets ().

- |             |              |
|-------------|--------------|
| Malfunction | Red (purple) |
| Warning     | Blue (gray)  |
| Release     | Green        |
| Other       | Black        |

## 5.10 Energy saving functions (Option)

These functions automatically control the indoor and outdoor units to lower power consumption.

There are 2 possible controls methods:

- Power Limit Control (recommended for high-demand season, i.e. summer): optimizes the power consumption trend and adjust set temperature of indoor units to remain below the target consumption;
- Eco mode: calendar based, stops indoor units intermittently or lowers capacity of outdoor units to lower the power consumption.

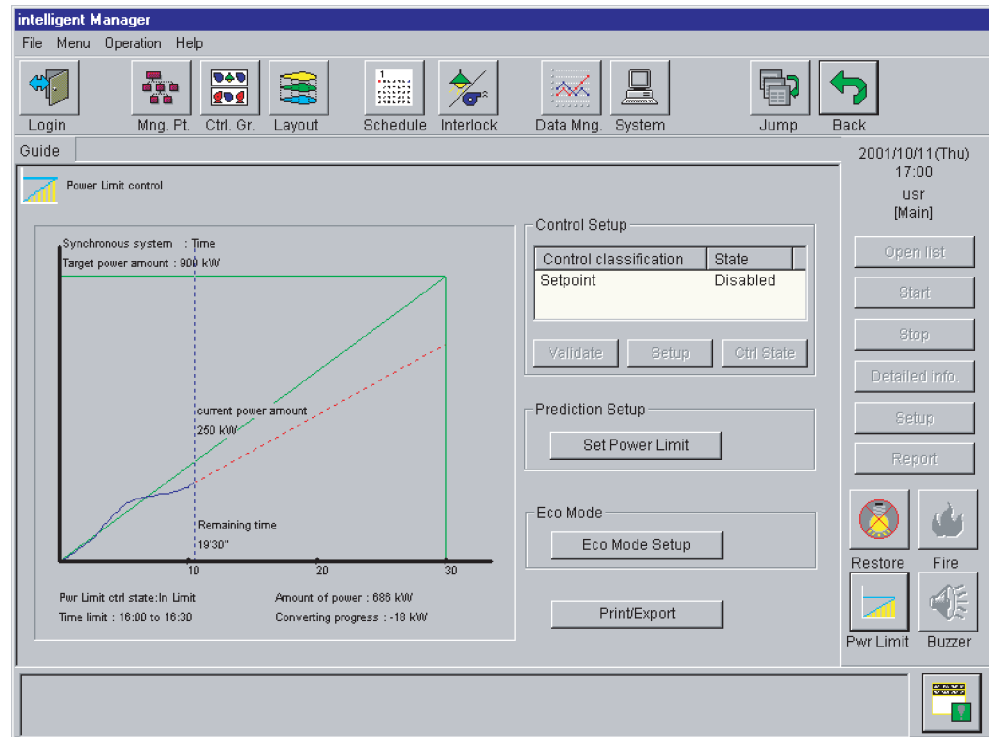

### 5.10.1 Power Limit Control

This limits based on target power measured on a pulse meter.

The setup is carried out in two steps:

- Set the power limit;
- Configure the control classifications:
  - Set temperature of indoor units;

#### 5.10.1.1 Setting the power limit

This procedure set up the calendar of the power limit values (measured on the pulse input management point configured by the system engineer beforehand) as shown below.

The value can differ for the summer period and for other seasons in order to provide specific control for higher demand.

As well, it can change daily according to up to 4 time zones. The time zones can overlap, but the current time is evaluated in priority from top (Peak Time) to down (Off-Peak Time).



According to the level of power consumption, increment/decrement of power value can be of 1, 10 or 100 kWh.

The maximum value of past year and month are displayed as shown below (see as well Power Graph section for display of actual data).

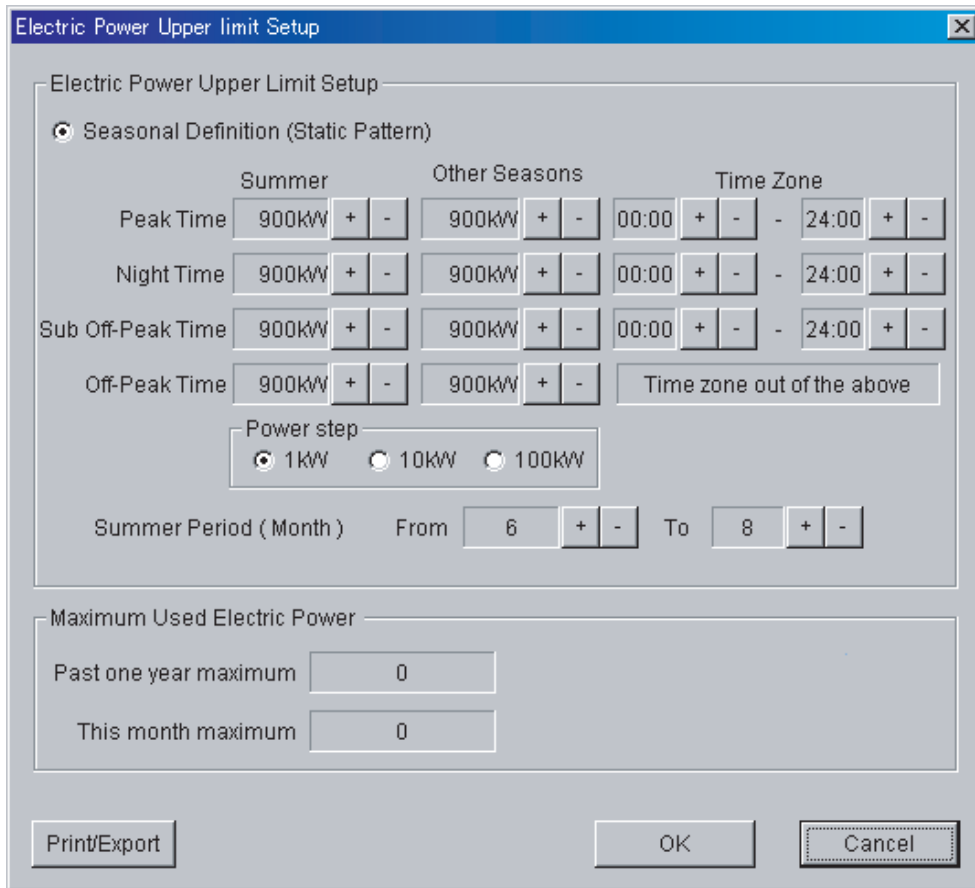

Operational procedure:

- Click the **Set Power Limit** button;
- Select the **Power Step**: 1 kW (small demand), 10 (medium demand), or 100 kW (large demand);
- Enter the limits of the **Summer Period** (from beginning of first to end of last month);
- Enter for each necessary time interval:
  - **Power Values** (for summer and other seasons);
  - daily **Time Zone**;
  - click on the **Print/Export** button to print all power limit data on the system printer or to save them in a CSV (comma separated) format file;
- Click the **OK** button.

#### 5.10.1.2 Setting the control parameters

This procedure set up the control groups, priorities and actions (set temperature of indoor units according to power demand: raise in cooling mode, lower in heating mode).

8 control groups are composed of indoor units are available and 8 levels of action are already configured in intelligent Manager:

- Level 1, 2: shift set temperature by 2 degrees,
- Level 3, 4: shift set temperature by 4 degrees,
- Level 5, 6: shift set temperature by 6 degrees,
- Level 7, 8: stop the indoor units (Thermostat Off).

Levels correspond to the power consumption trend compared with the target power consumption.

When the trend is aiming above the target, the level is incremented and action of this level is taken for each group

### Operational procedure

Click the **Validate** button to activate/deactivate the control;

- Initially, click the **Setup** button and perform settings of groups as explained below (control must be deactivated);
- At any time, Click the **Control State** button to check the adjustment on groups as explained below.

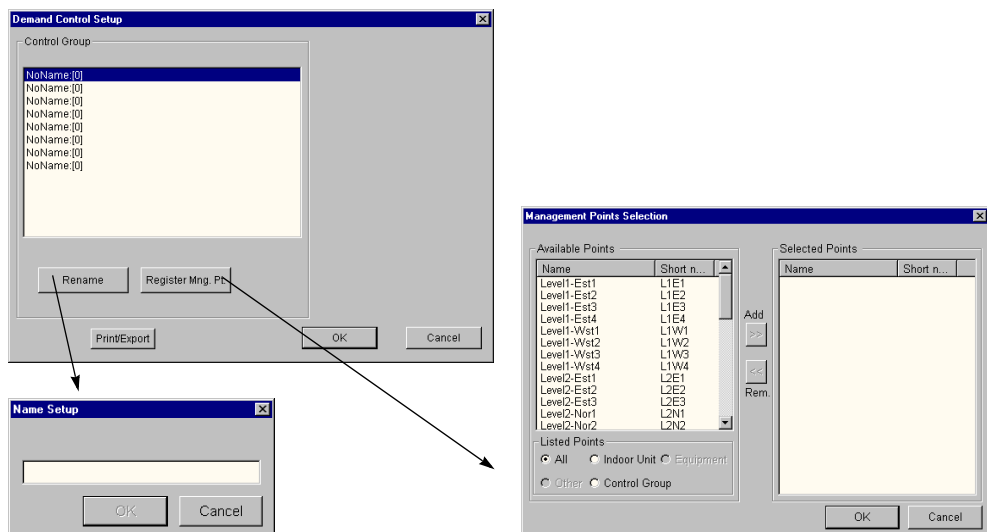

### Setting up the control parameters

Order of groups cannot be changed, however you can **Rename** the groups.

Proceed setup as explained below for each group:

- Register the indoor units (a same indoor unit cannot belong to more than one group):
  - click the **Register Mng. Pt** button;
  - select an indoor unit;
  - click the **>>** and **<<** buttons;
  - click the **OK** button to validate, or the **Cancel** button to abort;
- Click on the **Print/Export** button to print setting data on the system printer or to save them in a CSV (comma separated) format file;
- Click the **OK** button to validate, or the **Cancel** button to abort.

### Controlling the execution state

The control level of power limit, the status of the classification, and the temperature shift of each group is indicated.

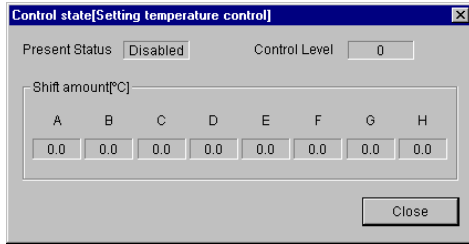

### 5.10.2 Setting up Eco Mode

Click the **Eco Mode Setup** button and select one of the two control classifications as shown below

#### 5.10.2.1 Setting up Intermittent operation control

This intermittently switches Off and On registered indoor units based on a calendar as shown below.

3 groups of indoor units can be defined, to be stopped for a ratio of 10 to 40% evenly within a 30 minutes cyclical interval during the calendar based seasons.

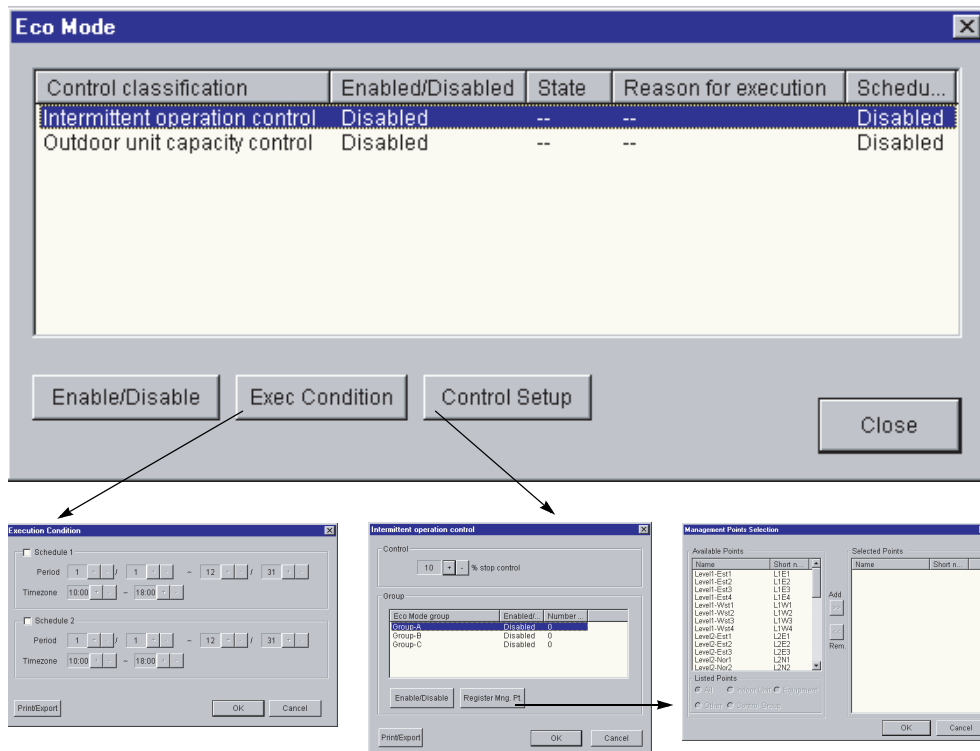

#### Operational Procedure:

- **Execution conditions:** Setup the calendars (2 seasons available with daily activation period) and check their box to **Enable** them, then click the **OK** button;
- click on the **Print/Export** button to print all calendars settings on the system printer or to save them in a CSV (comma separated) format file;

- Control setup:
    - select the interruption rate **Control** (10%, 20%, 30% or 40%): see example of interruption patterns below;
    - select each of the 3 available groups and **Register management points** of indoor units to be stopped (a same indoor unit cannot belong to more than one group);
    - **Enable** the groups;
    - click on the **Print/Export** button to print all groups settings on the system printer or to save them in a CSV (comma separated) format file;
    - click the **OK** button;
  - **Enable** the selected control classification;
  - Click the **Close** button.
- 

**Note** For a better result, do not register (i.e. stop at the same time) all indoor units of a same refrigeration circuit.

---

Examples of interruption patterns (grayed out) within 30 minutes (from 0' to 30') for rates of 10% to 40% in case of 1, 2, or 3 activated groups (approximate timing):

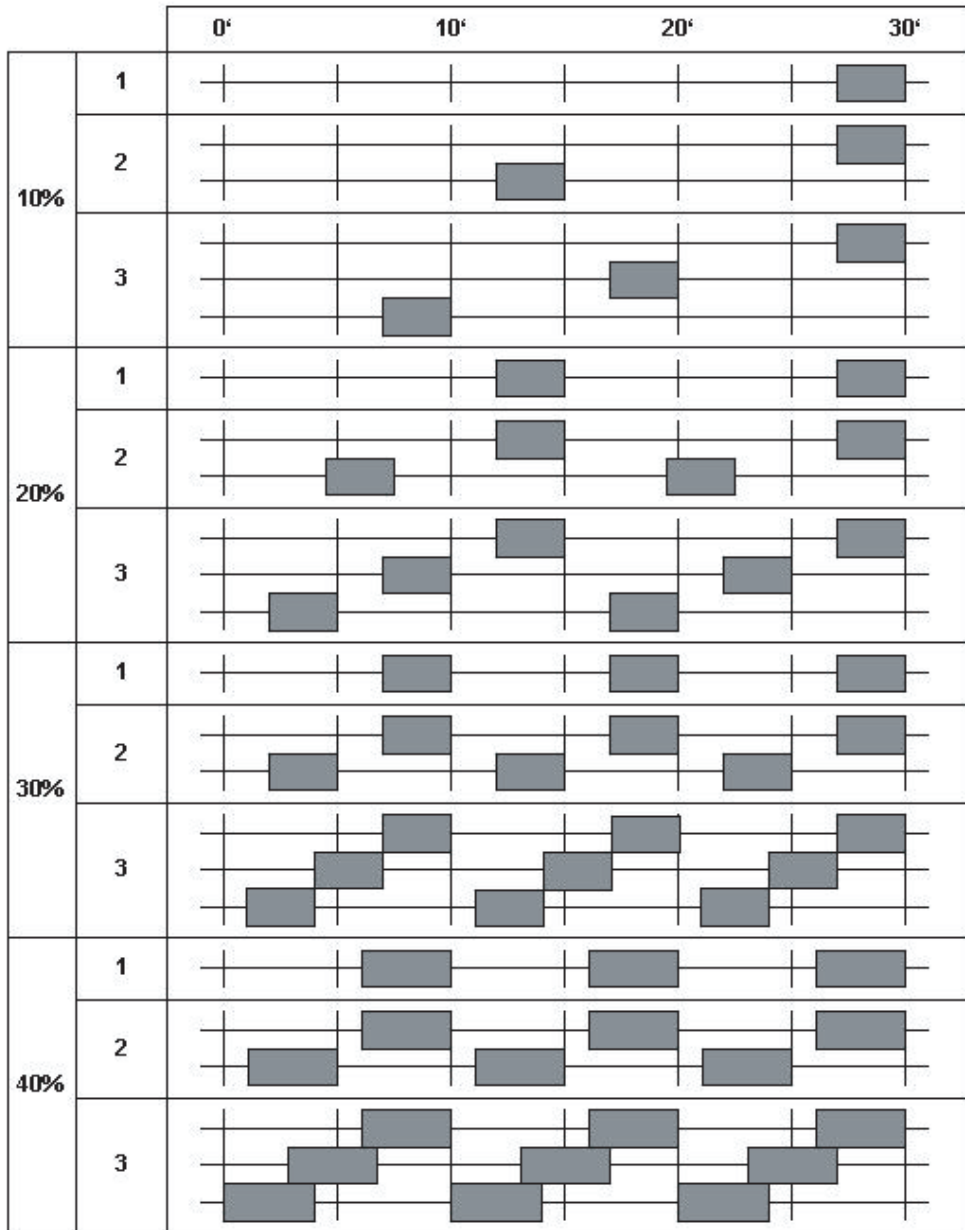

5.10.2.2 Setting up outdoor unit capacity control

This intermittently lowers capacity of registered outdoor units based on a calendar as shown below.

2 groups of outdoor units can be defined, for the capacity to be lowered for a ratio of 40 or 70% within the daily interval during the calendar based seasons.

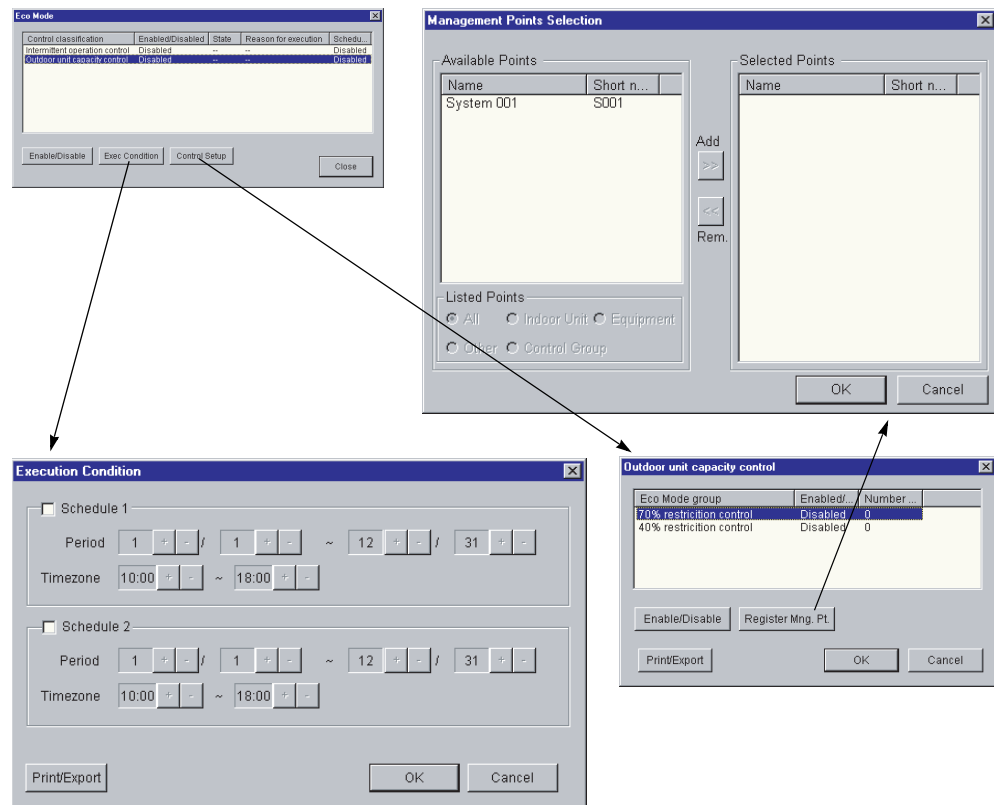

**Operational Procedure:**

- **Execution conditions:** Setup the calendars (2 seasons available with daily activation period) and check their box to **Enable** them, then click the **OK** button;
  - Click on the **Print/Export** button to print all calendars settings on the system printer or to save them in a CSV (comma separated) format file;
- **Control setup:**
  - select each of the 2 available groups and **Register management points** of outdoor units which capacity will be lowered;
  - **Enable** the groups;
  - click on the **Print/Export** button to print all groups settings on the system printer or to save them in a CSV (comma separated) format file;
  - click the **OK** button;
- **Enable** the selected control classification;
- Click the **Close** button.

## 5.11 Web Functions (Option)

### 5.11.1 Web Setting

- Set up the operation authority of the Web functions for each user ID.
- The user ID without operation authority cannot use the Web functions.
- If the Web option is invalid, the Web access restriction group box will not be displayed.
- The operation authority of the Web functions can be set up as follows:
  - Control functions authority
    - Regist Schedule
    - Regist Sum up Power Proportional Distribution's Data
    - Operate History
  - Control Group Edit
    - Control group to monitoring setting
- Only Web Administrator\*1 can set up the Control functions authority.
- The number of control groups you can register is 0 - 1024 groups per user (however, up to 10,000 groups for all users).

\*1 A Web Administrator is the user who has been granted the authority to operate all management points using the Web functions.

#### Operational Procedure

- Start intelligent Manager, then login as an administrator user
- Click the System menu button, the System Setup Screen displays
- Click the Set Login button, the Login Setup Screen displays
- The list of users already registered is displayed as in the figure below
- Perform explained hereafter
- \* The Web access restriction group box is displayed only when the Web Option is enabled.

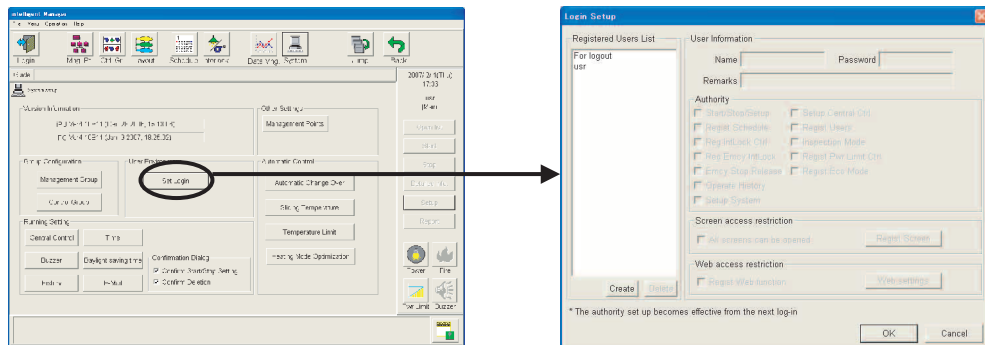

5.11.1.1 Web Access Restriction Setting

- Select user IDs whom you want to grant the Web operation authority in the Registered Users List, check the Regist Web function check box, and then click the Web settings button. The Web Setting screen appears.
- \* If no user ID is selected in the Registered Users List, or if For Logout is selected in the Registered Users List, the Regist Web function check box is grayed out.

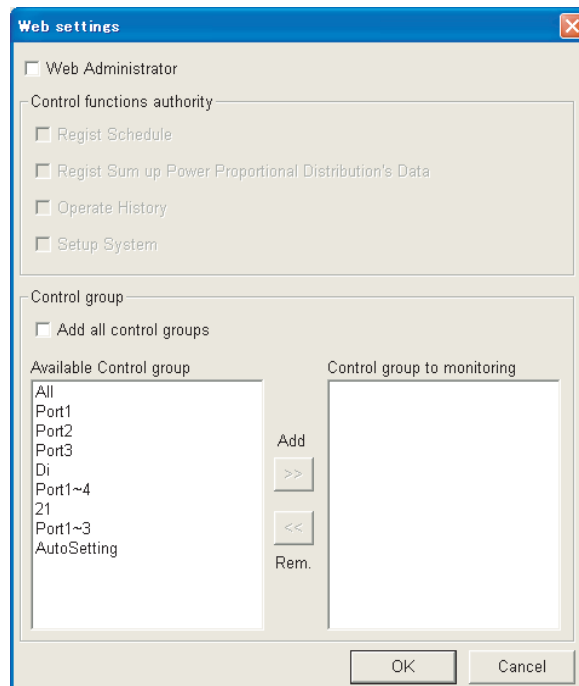
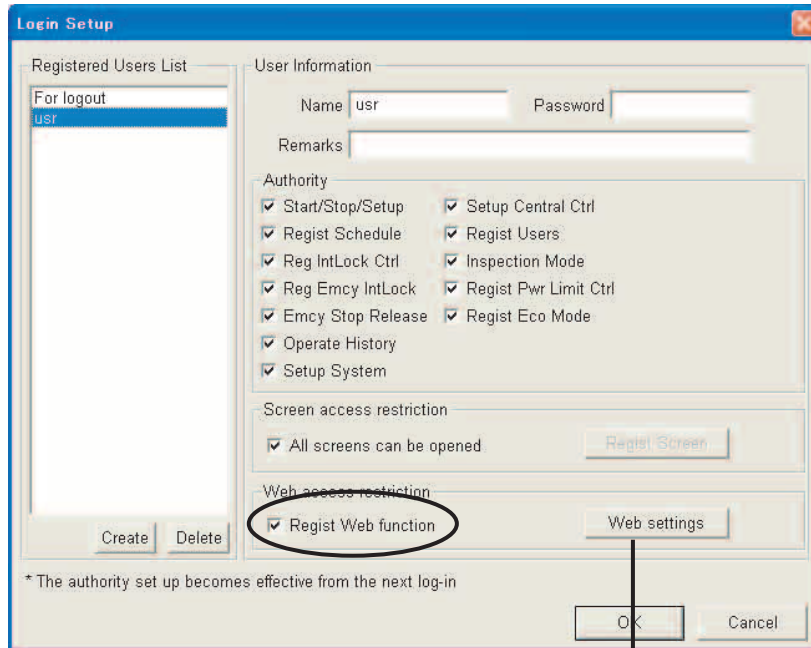



5.11.1.2 Web Setting

- To designate the selected user IDs for the Web Administrator, enable the Web Administrator check box. Set up the Control functions authority group box. If designated for the Web Administrator, the user IDs can operate all control groups, so the Control group box is grayed out.
- To designate the selected user IDs for the normal user authority, set up the Control Group Edi group box. If the Add All Control Group check box is enabled, the user IDs are enabled to operate all control groups using the Web functions. To set up the operational control groups using the Web functions, select the control groups whom you want to grant from the Available Control Group list, and click the Add button. The selected control groups are displayed in the Control group to monitoring list. To delete control groups from the Control group to monitoring list, select the control groups and click the Rem. button.
- \* Only the Web Administrator can set up the Control functions authority group box.
- \* If the Add All Control Group check box is enabled, the Available Control Group list, the Control group to monitoring list, the Add button, and the Rem. button are grayed out.

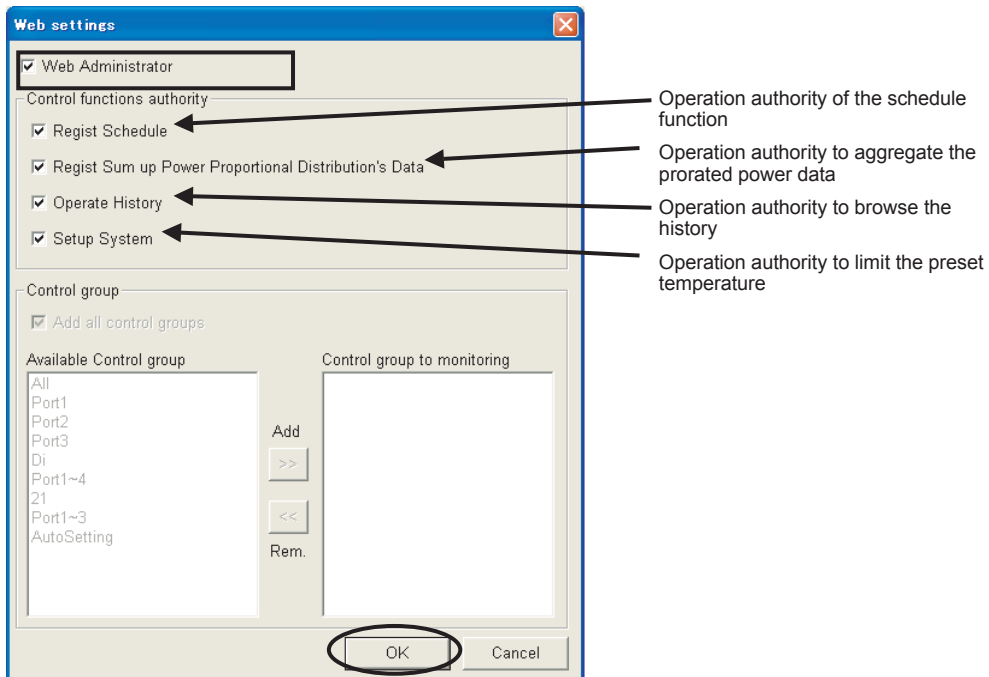

If the setup is completed, click the OK button.

### 5.11.2 E-Mail Setting

- When a malfunction occurs at a certain management point, an E-mail function sends the state such as an occurrence date and time, a malfunction code by E-mail to the preset E-mail address.
- A master iPU transmits the E-mails.

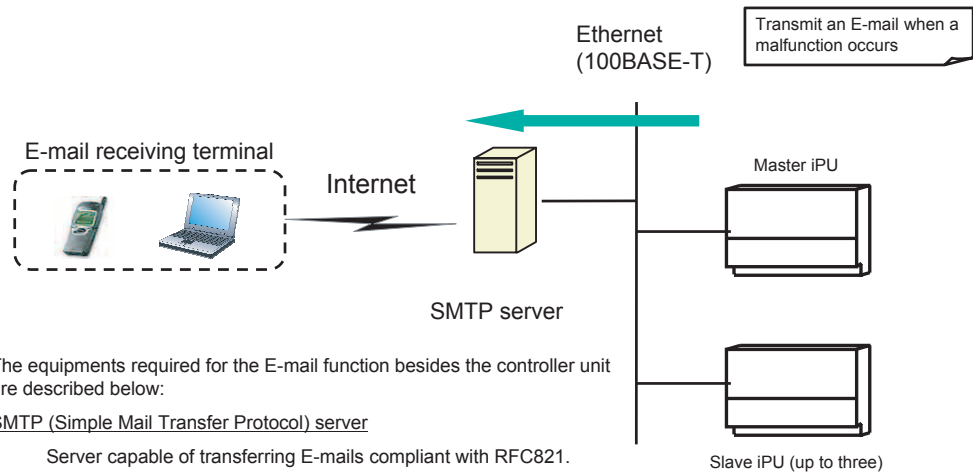

The equipments required for the E-mail function besides the controller unit are described below:

SMTP (Simple Mail Transfer Protocol) server

Server capable of transferring E-mails compliant with RFC821.

E-mail receiving terminal

Terminal capable of receiving E-mails compliant with RFC822.

#### **Management point type and transmission details**

The malfunctions transmitted by the E-mail function are as follows:

Malfunction type	Malfunction transmitted by the E-mail function
Equipment malfunction	○
Communication malfunction	×
Analogue upper/lower limit malfunction	○
Excessive cumulative start/stop count	×
Excessive cumulative operation time	×

The relationships, which can be registered as an object of the E-mail function, between the management point type and the malfunction type are as follows:

Management point type	Indoor Unit	AHU	Chiller	HRV	Internal Di *1	D3Di
Equipment malfunction	○	○	○	○	○	○
Analogue upper/lower limit malfunction						

Management point type	D3Dio	Pseudo Ai	D3Ai	Ai	Ao
Equipment malfunction	○		○	○	
Analogue upper/lower limit malfunction		○	○	○	○

\*1. You can register Internal Di only when the operation node "Used Mode" is set to an abnormal signal "Unusual Contact Point".

5.11.2.1 Setup items for the E-mail transmission

Category	Item	Number of characters, restrictions	Factory defaults	Description	
Whole	Enable/disable E-mail function		Disabled	If disabled, E-mails will not be transmitted	
SMTP server	SMTP server address	Up to 128 single-byte characters.	Blank	Specify a SMTP server URL (IP address)	
	SMTP server port number	1 – 65535	25	Specify a SMTP server port number	
	Enable/disable "POP before SMTP" function		Disabled	Specify whether to access the specified POP server before the E-mail transmission	
	Setup items when the "POP before SMTP" function is enabled	POP server address	Up to 128 single-byte characters.	Blank	Specify the POP server URL (IP address)
		POP server port number	1 – 65535	110	Specify the POP server port number
		POP user ID	Up to 64 single-byte characters.	Blank	User ID used for the POP authentication
POP password		Up to 64 single-byte characters.	Blank	Password used for the POP authentication	
Transmission condition	Transmission destination		None	Specify the management point to which an E-mail is transmitted when a malfunction occurs	
	Retransmission interval	1-72 hours. In hours	Two hours	Retransmit interval of an E-mail	
	Site name	Up to 20 double-byte/single-byte characters.	Blank	Specify the text displayed in the Subject field of the E-mail	
E-mail	E-mail address 1, 2, 3	Up to 128 single-byte characters	Blank	Specify an E-mail address (aaa@bbb.co.jp). Optional.	

5.11.2.2 E-mail transmission timing

- When a malfunction occurs in the target groups for the E-mail transmission, an E-mail is transmitted after the transmission waiting time elapsed (three minutes) since the malfunction occurrence ((1) in the figure). The abnormal detection is carried out by polling the abnormal information of the target group every one minute.
- If a malfunction occurs at another management point in the transmission waiting state, the multiple malfunctions are grouped into one E-mail and then transmitted ((2), (3) in the figure).
- After the retransmission interval time (two hours by default) elapsed since the first E-mail transmission, if the malfunction last transmitted by the E-mail still continues, the E-mail is retransmitted ((2) in the figure).
- If an equipment malfunction occurs at another management point during retransmitting the E-mail, an E-mail is transmitted after the retransmission interval time elapsed ((4) in the figure).
- If the normal/abnormal state changes within the next retransmission interval in the management point whose E-mail has already been transmitted, the latest occurrence date and time and a malfunction code are transmitted ((5) in the figure).
- The retransmission state will change into the normal state, if any E-mail transmission item in the E-mail setting is changed. However, the E-mail which is ready for transmission is transmitted.
- The retransmission state will change into the normal state, if the system time is changed. However, the E-mail which is ready for transmission is transmitted.

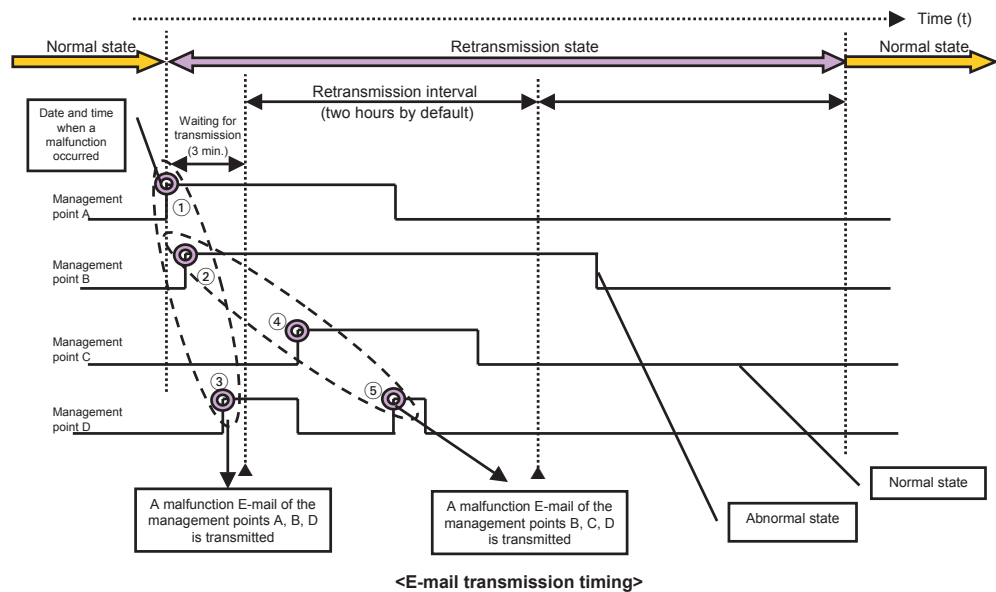

### 5.11.2.3 E-mail format

- The E-mail format is as follows: If three or more malfunctions are transmitted at the same time, two with the newest occurrence date and time are displayed and only the count is displayed for the remaining malfunctions.

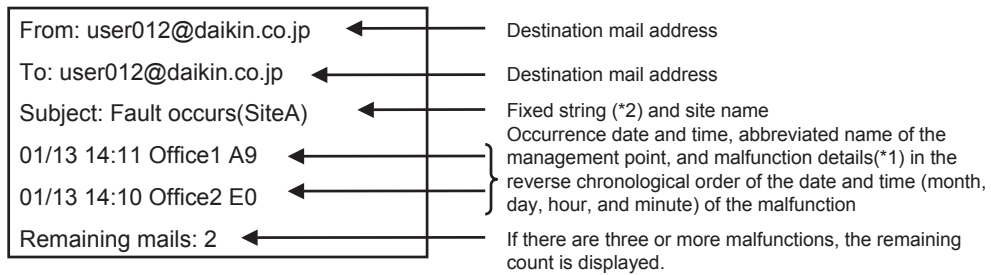

\*1: The malfunction details as follows:  
 [Equipment malfunction]  
 Malfunction code (nothing displayed if the code does not exist)  
 [Analogue upper limit malfunction]  
 "Upper limit"  
 [Analogue lower limit malfunction]  
 "Lower limit"

### 5.11.2.4 Trial mail

- In order to check the E-mail transmission setting, you can send a trial mail to the destination E-mail address. The trial mail format is as follows:

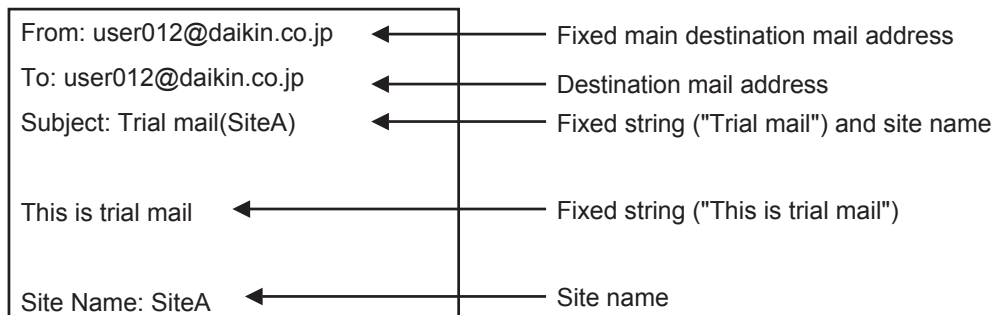

### 5.11.2.5 Operational Procedure

- Start intelligent Manager, then login as an administrator user
- Click the System menu button, the System Setup Screen displays
- Click the Set E-Mail button, the Setting of E-mail Screen displays
- Perform explained hereafter
- \* The E-Mail button appears only when Web Option is enabled.

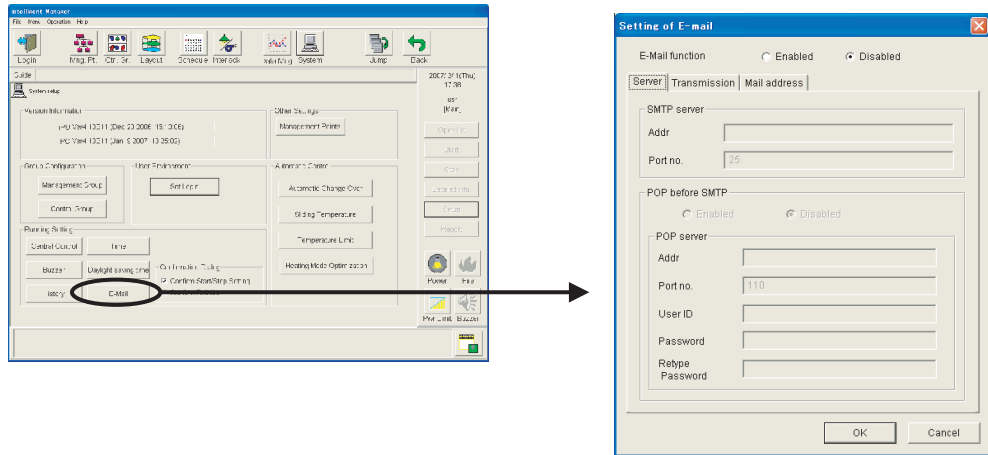

### 5.11.2.6 Setting of E-mail - SMTP sever setting -

- Enable the E-Mail function radio button, and then set up a SMTP server Addr (SMTP server's URL or IP address) and the Port No. (Port No. default setting is 25.)

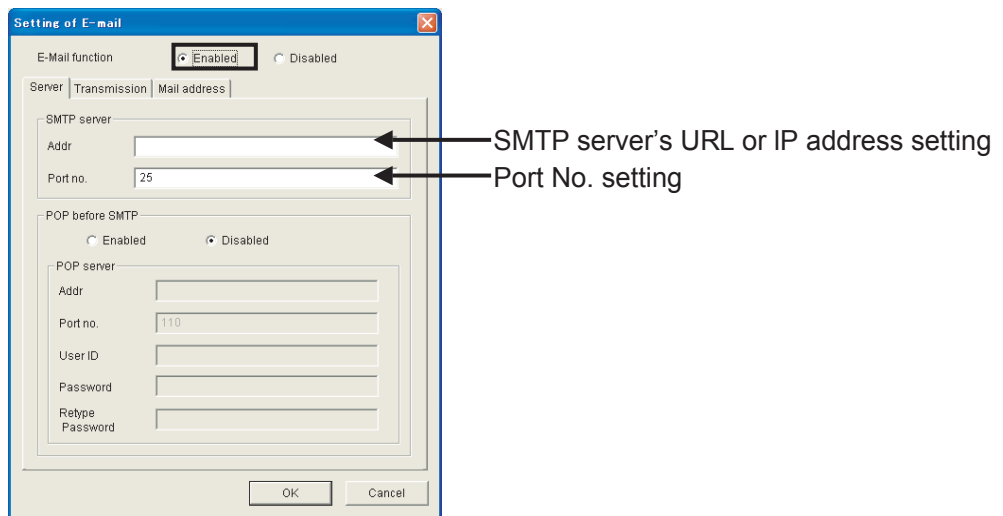

5.11.2.7 Setting of E-mail - POP before SMTP setting -

- To connect to a POP server before the E-mail transmission, enable POP before SMTP and then set up the POP server's Addr (POP server's URL or IP address), Port No., User ID, Password, and Retype Password. (Port No. default setting is 110.)
- \* If POP before SMTP is disabled, the POP before SMTP group box will be grayed out.
- \* The asterisk [\*] characters are displayed instead of the typed Password, Retype Password.

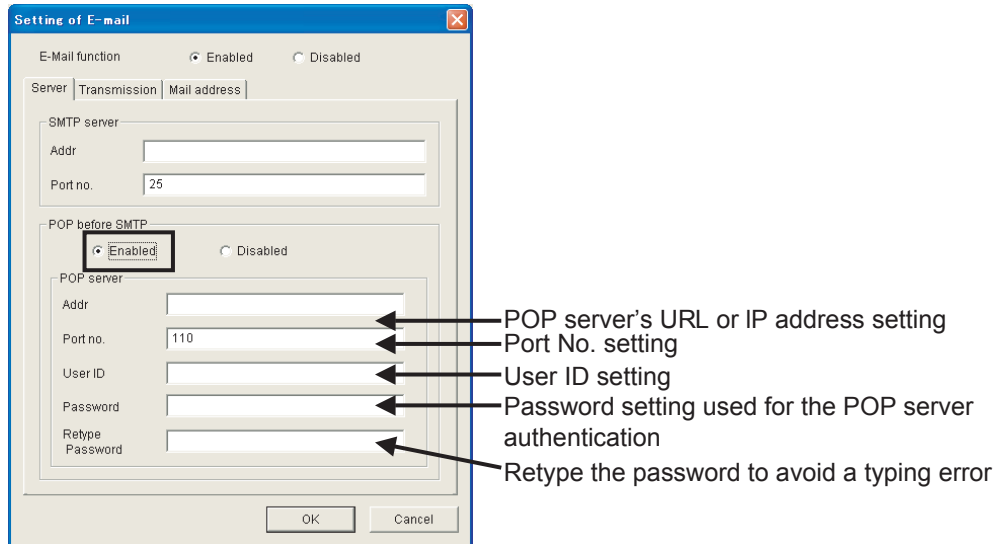

### 5.11.2.8 Setting of E-mail - Transmission setting -

- Carry out a setting for the E-mail transmission.
- Click the Transmission tab. The Transmission setting screen appears.
- Set up a site name (Subject) used when sending E-mails in the Site Name edit box. (up to 20 characters)
- Set up an E-mail's retransmission interval in the Resend interval combo box. The valid range is 1-72 hours in steps of one hour. (The default interval is two hours.)
- The management points not yet monitored for malfunctions are listed in the Unregistered list, and the management points being monitored for malfunctions are listed in the Registered list.

To monitor points for malfunctions, select the management points appeared in the Unregistered list, and click the Add button. They are added to the Registered list. To release the malfunction monitoring, select the management points appeared in the Registered list, and click the Rem. button. They are deleted from the Registered list and moved to the Unregistered list. (The management points added to the Registered list are not displayed in the Unregistered list.)

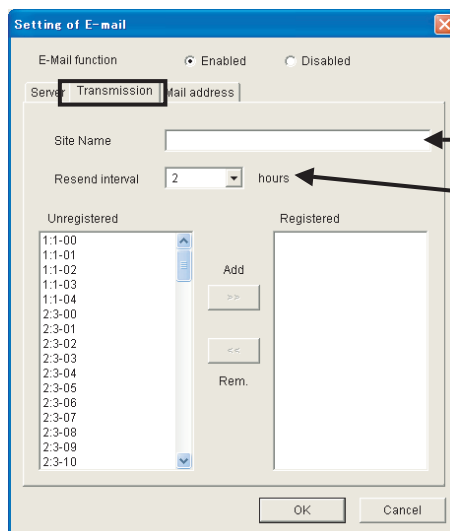

Enter a site name (Subject filed) (up to 20 characters)

Set up a retransmission interval

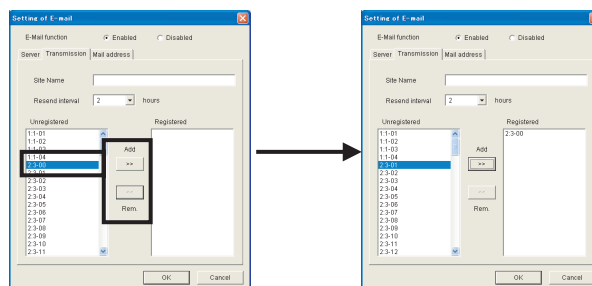

To monitor points for malfunctions, select the management points appeared in the Unregistered list, and click the Add button. They are added to the Registered list. To release the malfunction monitoring, select the management points appeared in the Registered list, and click the Rem. button.



5.11.2.9 Setting of E-mail –Mail address setting -

- Carry out a destination setting for the E-mail transmission.
- Click the Mail address tab. The Mail address screen appears.
- Click the Add button. The Mail address edit screen appears.  
 Enter an address to which you want to send an E-mail, and click the OK button.  
 The mail address is added to the Mail address list.  
 To send an E-mail to other receiving terminals, click the Add button and add a mail address.  
 You can set up to three mail addresses.
- To edit a mail address, select the mail address which you want to edit in the Mail address list, and then click the Modify button.  
 Since the Mail address edit screen appears, edit the mail address.
- To delete the registered mail addresses, select mail addresses which you want to delete from the Mail address list, and click the Delete button. When a confirmation screen is displayed, click the OK button. The selected mail addresses are deleted.  
 To cancel, click the Cancel button. The screen returns to the Mail address screen without deleting the selected mail addresses.
- To check whether an E-mail can reach the receiving terminal at the defined mail address, select a mail address which you want to send and click the Trial mail button. A setup confirmation screen appears. Click the OK button. When a transmission confirmation screen is displayed, check the settings and click the Yes button. If the setting is correct, the receiving terminal will receive the trial mail.  
 If the trial mail is not received, check the setting on pages 121 - 123.

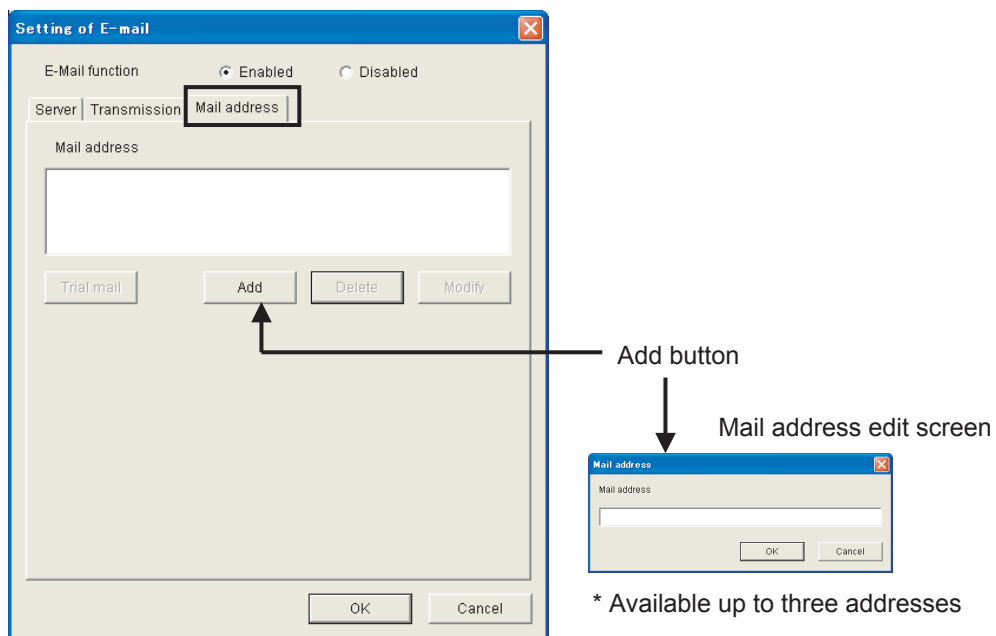

5.11.2.10 Setting of E-mail

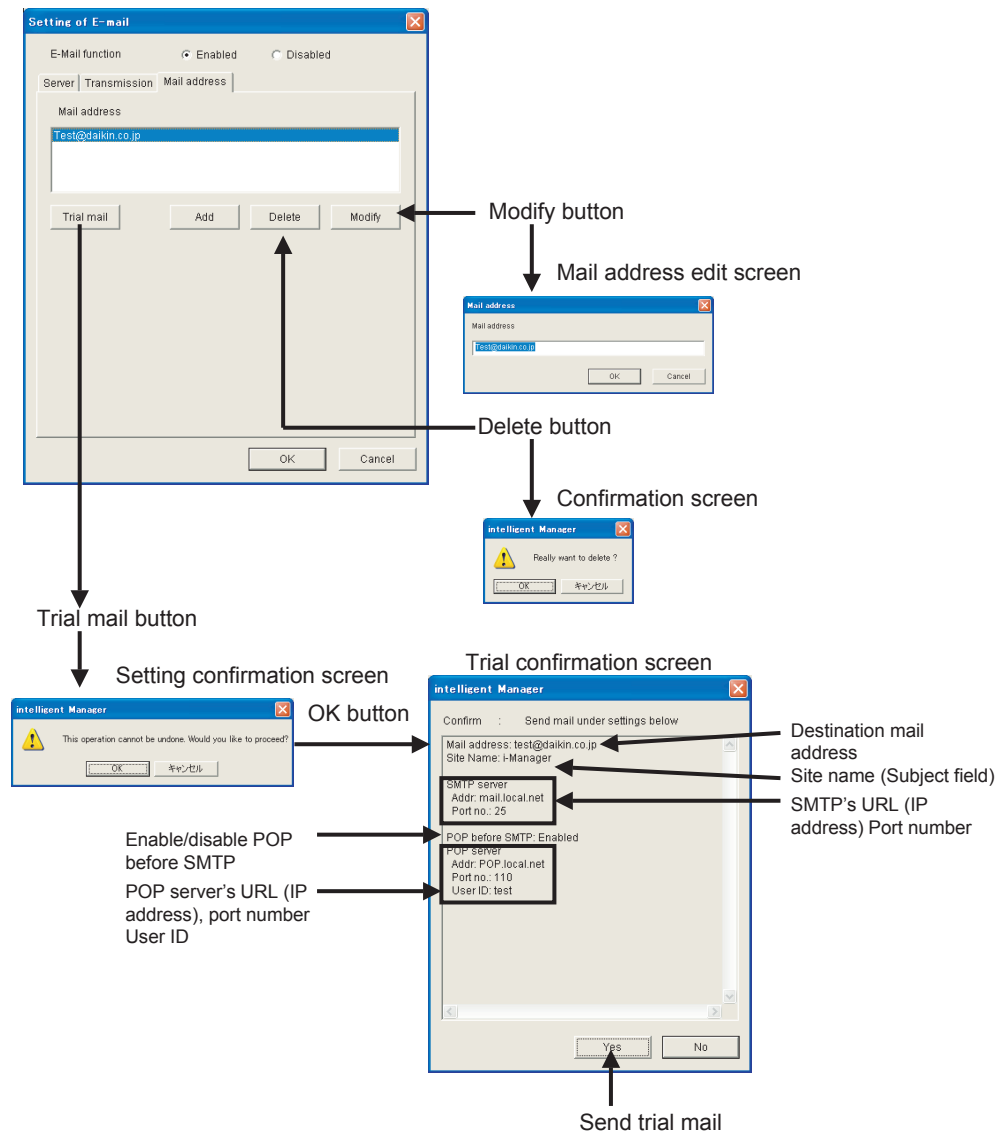

If the trial mail is successfully sent to the receiving terminal, it will receive the following mail (example).

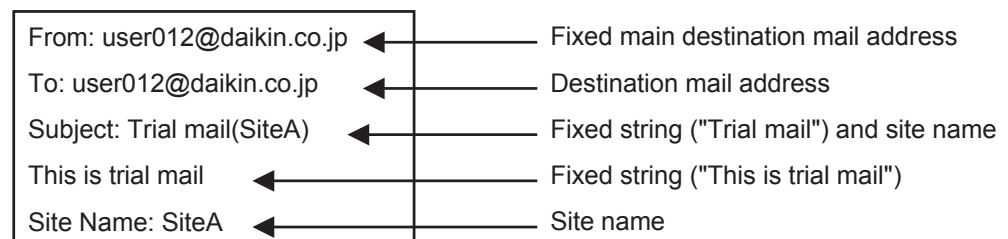

- If each setup is completed, click the OK button to exit the Setting of E-mail. The screen returns to the System Setup screen.
- If there is any error on setting values of the SMTP server, POP server, and so on, the setting value error screen appears.
- \* If you disabled the E-mail function and then clicked the OK button, the SMTP server value and so on specified when the function is enabled are reset to the initial values. However, if the function is switched from disabled to enabled while displaying the Setting of E-mail screen, values specified when the function is enabled are displayed.

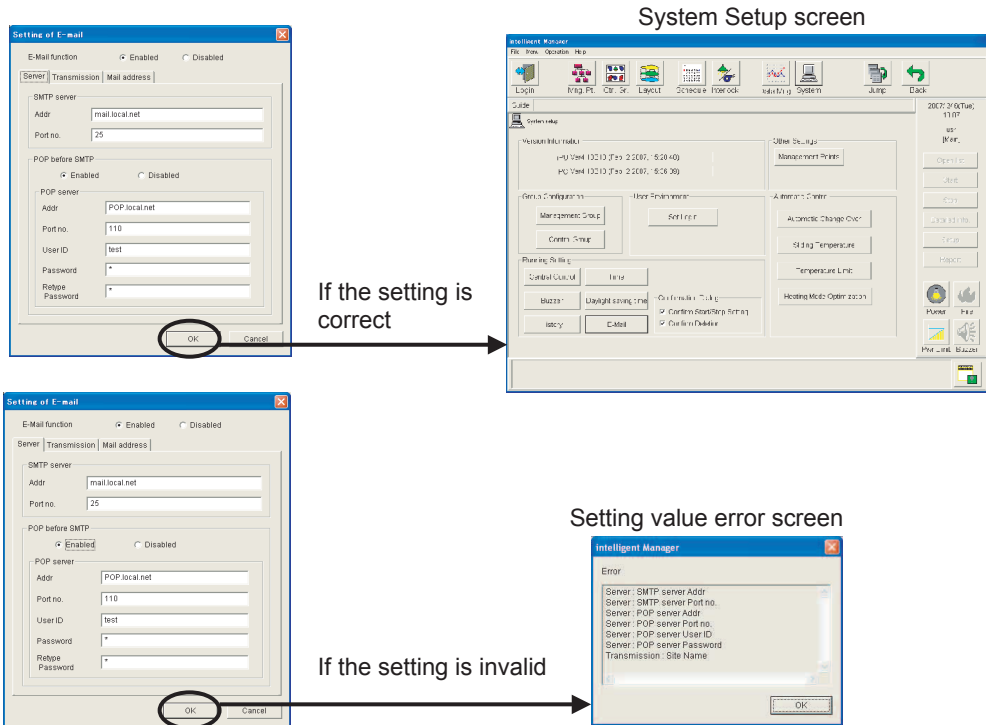

<Correspondence table between error descriptions and error messages>

Tab	Error location	Error condition	Error message
Server	(1)[Addr] edit box	When the input string exceeds 128 characters, or it contains any character other than single-byte characters	Server : SMTP server Addr
	(2)[Port no.] edit box	When any character other than numeric characters is entered, or out of the numeric range 1-65535	Server : SMTP server Port no.
	(4)[Addr] edit box	When the input string exceeds 128 characters, or it contains any character other than single-byte characters	Server : POP server Addr
	(5)[Port no.] edit box	When any character other than numeric characters is entered, or out of the numeric range 1-65535	Server : POP server Port no.
	(6)[User ID] edit box	When the input string exceeds 64 characters, or it contains any character other than single-byte characters	Server : POP server User ID
	(7)[Password] edit box [Retype Password] edit box	When the input string exceeds 64 characters, it contains any character other than single-byte characters, or two passwords do not match	Server : POP server Password
	Transmission	(1)[Site Name] edit box	When the input string exceeds 20 characters

## 6. Database Maintenance

This section explains which action should be taken when the size of the intelligent Manager database becomes excessive.

The capacity of the intelligent Manager database is limited only by the available space on the hard disk of the computer.

When this limit becomes close (less than 10 Megabytes), intelligent Manager issues a warning in the History screen.

The procedure consists in deleting the oldest items from the database by making use of the ezDBMaintenance tool as described below.

---

**Warning** Always backup the current database (on a separate hard-disk, on CD-Rom, etc.) before performing any maintenance operation.

---

**Step 1:** exit from intelligent Manager.

See details of this operation in the section 3. Starting and Stopping operation of intelligent Manager.

**Step 2:** backup the database.

This operation can be performed either by using an external device (CD writer, serial connection to another PC, etc.) and will not be discussed in details in the present document. Please refer to your support engineer for advice.

**Step 3:** start the ezDBMaintenance.exe module (located in the same folder as intelligent Manager VRV.exe module) as shown below.

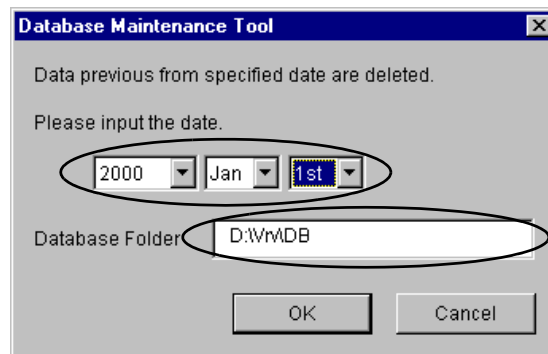

**Step 4:** input the parameters as shown above:

- Database Folder: the path of database folder (absolute path is recommended);
- Date: all the items until the day BEFORE this date will be deleted.

Then click the **OK** button. The confirmation dialogue displays as shown below.

**Step 5:** carefully check the date and size of both deleted and remaining data.

- To change the parameters, click the **Cancel** button. The previous dialogue displays again as shown above.

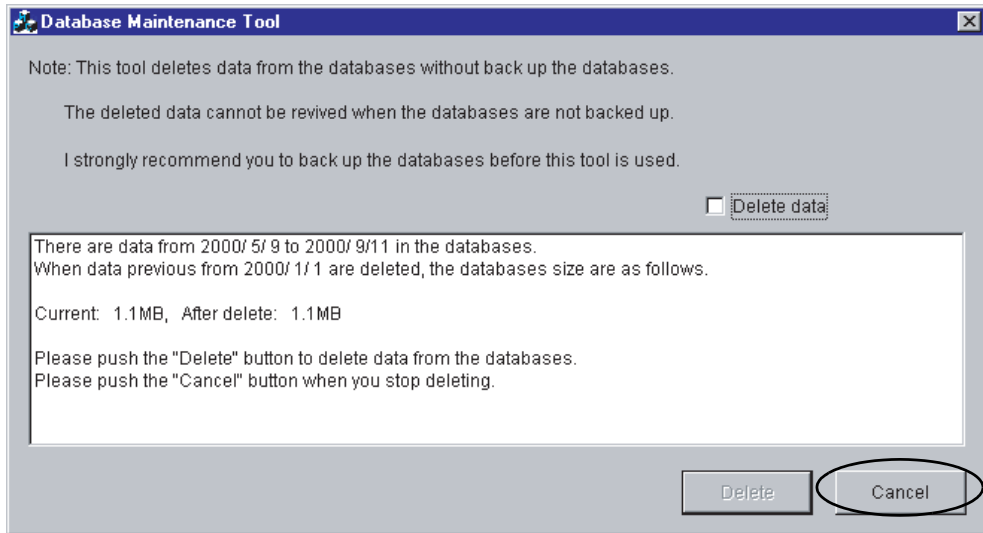

If the parameters are correct, then go ahead for data deletion:

- check the Delete Data box; the **Delete** button is now enabled as shown below;

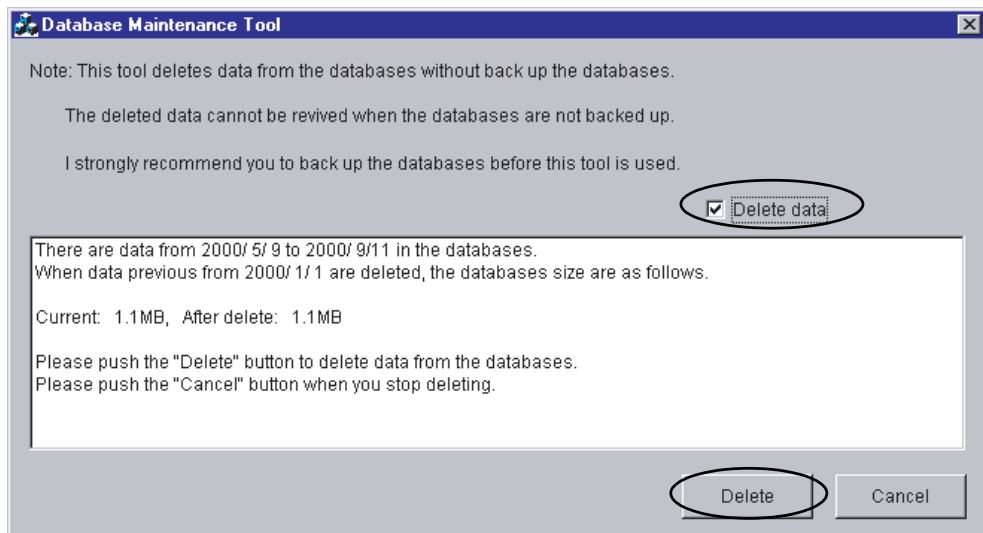

- click the **Delete** button; the confirmation dialogue displays as shown below.

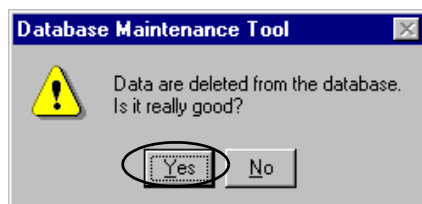

**Step 6:** click the **Yes** button; the result message displays as below.

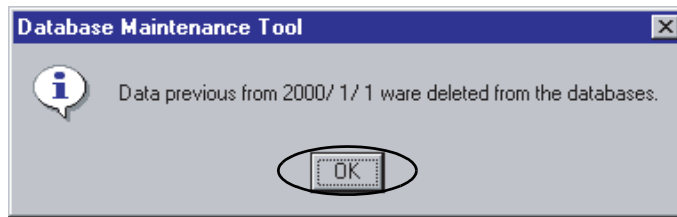

**Step 7:** Click the **OK** button.

End of procedure.

## 7. Troubleshooting

### What to be careful of and what to do when operations cannot be performed

Depending on the type of problem - related to Windows XP (or Windows 2000) or the internal working of the system - the present system might display an error message window of total operation inability.

#### Warning

If this happens, part of the data, cumulative values etc. may be lost. Furthermore once intelligent Manager has been shut down, the error message display area is cleared.

If the following troubleshooting strategies have been carried out and problems persist after the system has been restarted, please contact the Daikin service counter.

### Forcing Windows shutdown

While holding down simultaneously the Ctrl and Alt keys on the keyboard, press the Delete key (Ctrl+Alt+Del).

Click the **Task Manager (T)** button on the Windows security screen to display the screen shown below.

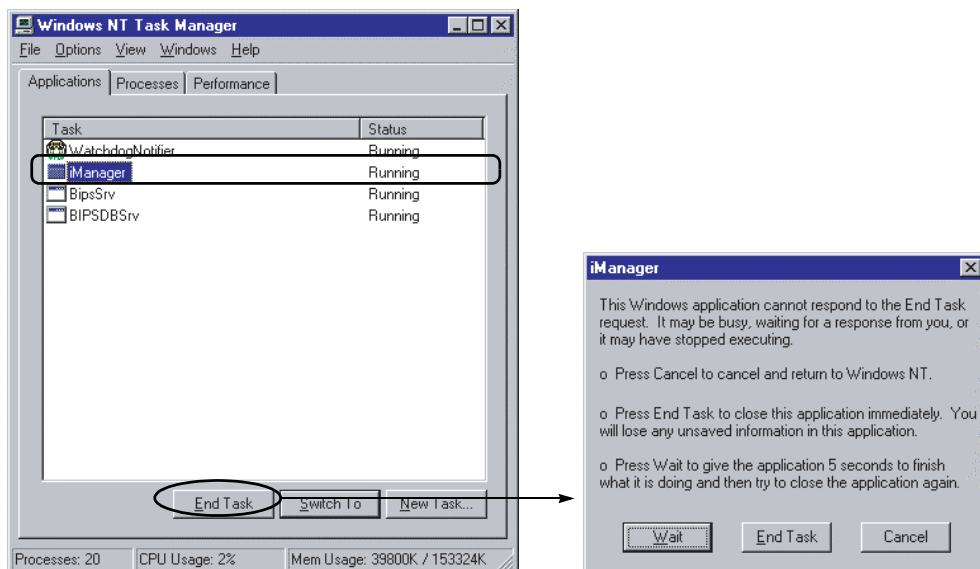

Select the intelligent Manager icon and click the **End Task (E)** button.

#### Warning

End only intelligent Manager.  
If other programs are ended, the computer should be restarted.

All inquiries about after sales service etc. should be addressed to Daikin.

#### Notes

- (1) Illegal reproduction of this document or of any part thereof is strictly prohibited.
- (2) Any part of this document may be changed in the future without prior notice.

- (3) Every effort has been made to ensure the accuracy of this document. However please do not hesitate to contact us in the case of any missing, erroneous or unclear information.
  - (4) No liability can be assumed for any loss etc. resulting from customer misuse of our products, failure to comply with the instructions contained in this manual, repairs or modifications carried out by a third party other than Daikin etc.
-







## Using Intelligent Manager III

1. To use intelligent Manager, it is necessary to purchase additional equipment, such as a personal computer and a UPS. Contact your distributor or the manufacturer for details.
2. Installation of intelligent Manager must be performed by a Daikin-trained engineer.
3. Do not install additional software, such as games, on the personal computer used to run intelligent Manager.
4. Changing the system settings of the personal computer used to run intelligent Manager could cause intelligent Manager to malfunction. Do not change the personal computer's system settings under any circumstances.
5. Once a month, adjust the clock of the personal computer and IPU used to run intelligent Manager.

- The contents within this catalogue are effective as of Sep 2007. Note that changes to the content due to product improvements and the like may be conducted without prior notice.
- Please contact a Daikin representative before using an Intelligent Manager III.
- Besides Intelligent Manager III, Daikin also markets various other A/C management devices. Feel free to contact Daikin for catalogues or any necessary information.
- Ethernet is a registered trademark of Xerox corporation.



JMI-0107



JQA-1452

#### About ISO 9001

ISO 9001 is a plant certification system defined by the International Organization for Standardization (ISO) relating to quality assurance. ISO 9001 certification covers quality assurance aspects related to the "design, development, manufacture, installation, and supplementary service" of products manufactured at the plant.



EC99J2044

#### About ISO 14001

ISO 14001 is the standard defined by the International Organization for Standardization (ISO) relating to environmental management systems. Our group has been acknowledged by an internationally accredited compliance organisation as having an appropriate programme of environmental protection procedures and activities to meet the requirements of ISO 14001.

### Dealer

#### **DAIKIN INDUSTRIES, LTD.**

Head Office:  
Umeda Center Bldg., 2-4-12, Nakazaki-Nishi,  
Kita-ku, Osaka, 530-8323 Japan

Tokyo Office:  
JR Shinagawa East Bldg., 2-18-1, Konan,  
Minato-ku, Tokyo, 108-0075 Japan

[http://www.daikin.com/global\\_ac/](http://www.daikin.com/global_ac/)

©All rights reserved