

WARNING
This is a class A product. In a domestic environment this product may cause radio interference in which case the user may be required to take adequate measures.

Please read these "SAFETY CONSIDERATIONS" carefully before installing this unit and be sure to install it correctly. After completing the installation, make sure that the unit operates properly during the start-up operation. Please instruct the customer on how to operate the unit and keep it maintained. Also, inform customers that they should store this installation manual along with the operation manual for future reference. This unit comes under the term "Appliances not accessible to the general public".

Meaning of warning, caution and note symbols.

- ▲ WARNING** Indication a potentially hazardous situation which, if not avoided, could result in death or serious injury.
- ▲ CAUTION** Indication a potentially hazardous situation which, if not avoided, may result in minor or moderate injury. It may also be used to alert against unsafe practices.
- ▲ NOTE** Indication situation that may result in equipment or property-damage-only accidents.

▲ WARNING

Ask your dealer or qualified personnel to carry out installation work. Do not try to install the machine by yourself. Improper installation may result in electric shocks or fire.

Perform installation work in accordance with this installation manual. Improper installation may result in electric shocks or fire.

Be sure to use only the specified accessories and parts for installation work. Failure to use the specified parts may result in electric shocks, fire or the unit falling.

Carry out the specified installation work after taking into account earthquakes. Improper installation work may result in the equipment falling and causing accidents.

Make sure that a separate power supply circuit is provided for this unit and that all electrical work is carried out by qualified personnel according to local laws and regulations and this installation manual. An insufficient power supply capacity or improper electrical construction may lead to electric shocks or fire.

Make sure that all wiring is secured, the specified wires are used, and no external forces act on the terminal connections or wires. Improper connections or installation may result in fire.

When wiring the power supply and connecting the remote controller wiring and transmission wiring, position the wires so that the electric parts box lid can be securely fastened. Improper positioning of the electric parts box lid may result in electric shocks, fire or the terminals overheating.

Before touching electrical parts, turn off the unit.

Ground this unit. Do not connect the ground wire to gas or water pipes, lightning rod or a telephone ground wire. Incomplete grounding may result in electric shocks.

Do not reconstruct or change the settings of the protection devices. If the pressure switch, thermal switch, or other protection device is shorted and operated forcibly, or parts other than those specified by Daikin are used, fire or explosion may result.

Do not touch the switch with wet fingers. Touching a switch with wet fingers can cause electric shock.

Install an leak circuit breaker, as required. If an leak circuit breaker is not installed, electric shock may result.

DO NOT install this unit in the following locations.

- (a) where a mineral oil mist or an oil spray or vapor is produced, for example in a kitchen, plastic parts may deteriorate and fall off or result in water leakage.
- (b) where corrosive gas, such as sulfuric acid gas, is produced, Corroding copper pipes or soldered parts may result in refrigerant leakage.
- (c) near machinery emitting electromagnetic waves. Electromagnetic waves may disturb the operation of the control system and result in malfunction of the equipment.
- (d) where flammable gases may leak, where there are carbon fiber or ignitable dust suspensions in the air, or where volatile flammables such as thinner or gasoline are handled. Operating the unit in such conditions may result in fire.

▲ CAUTION

Be very careful about product transportation.

Safely dispose of the packing materials. Packing materials, such as nails and other metal or wooden parts, may cause stabs or other injuries. Tear apart and throw away plastic packaging bags so that children will not play with them. If children play with a plastic bag which was not torn apart, they face the risk of suffocation.

▲ NOTE

Install this unit, power supply wiring and connecting wires at least 3.5ft. away from televisions or radios in order to prevent image interference or noise. (Depending on the radio waves, a distance of 3.5ft. may not be sufficient enough to eliminate the noise.)

This unit is a class A product.

In a domestic environment this product may cause radio interference in which case the user may be required to take adequate measures.

Dismantling of the unit, treatment of the refrigerant, oil and eventual other parts, should be done in accordance with the relevant local and national regulations.

Before commissioning by a NI (Network Integrator), make sure to turn ON the battery backup switch. If the battery backup switch is in OFF position, even if commissioning is carried out, all data set at commissioning will be cleared when the power supply to DMS504B71 is turned OFF. In such a case, commissioning will be needed again by NI and additional cost will be charged.

The neuron ID is indicated on the control PC Board by seal. See the paragraph 6, Names and function of P.C.B. ASSY.

For safety, lock the door with the key except for maintenance.

1 Components

The following parts are attached to this unit. Make sure to check them before installation.

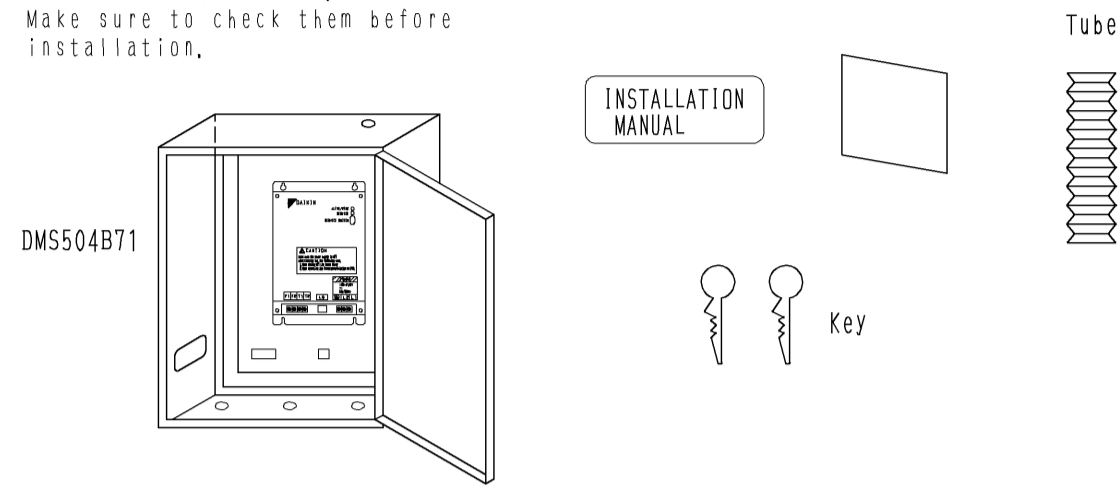

2 Names and functions of each part

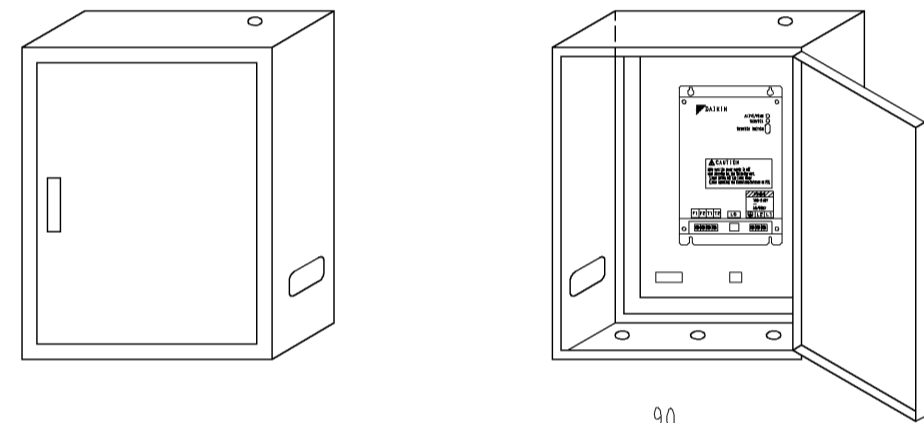

[UNIT: mm]

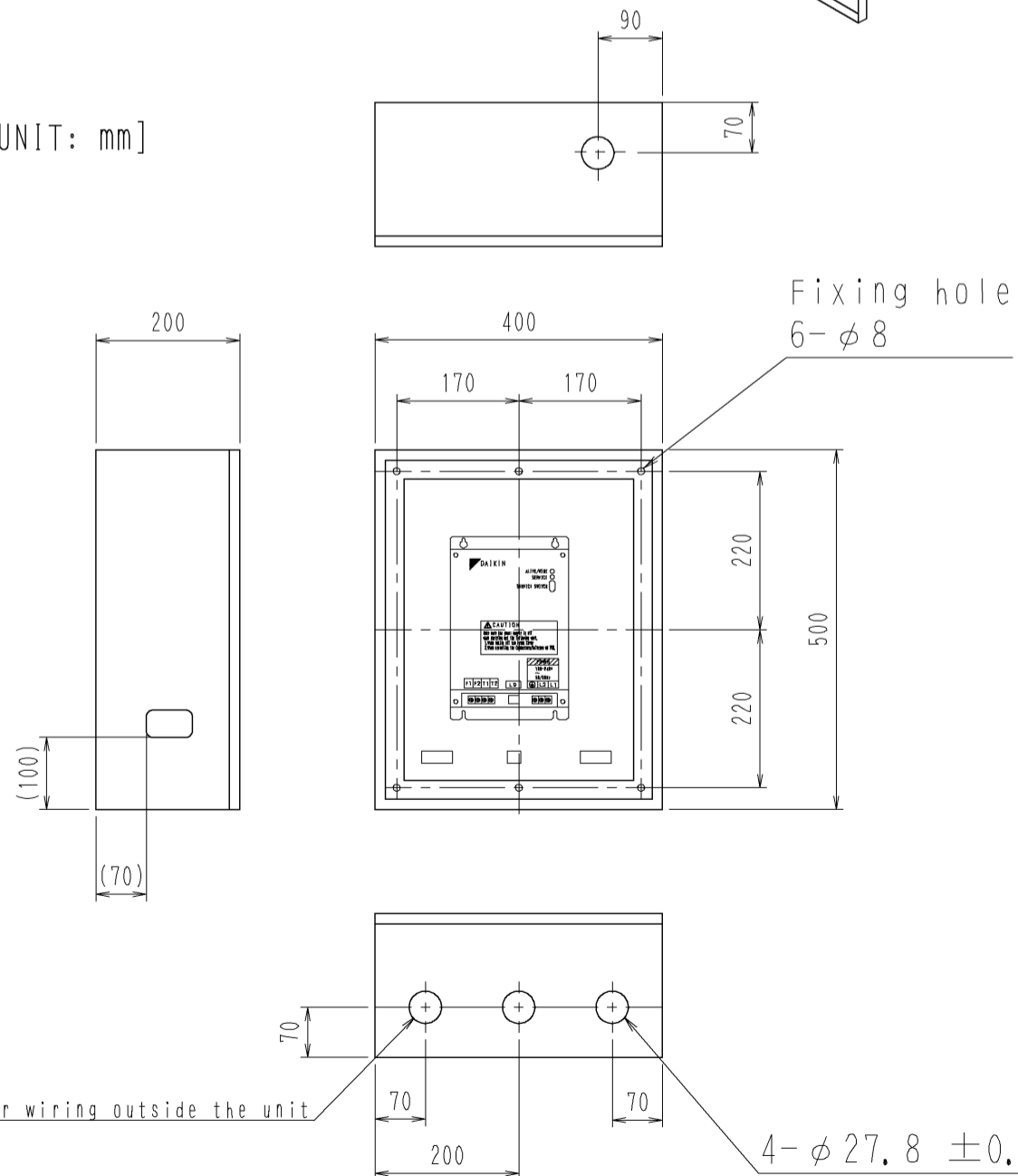

UNLESS OTHERWISE SPECIFIED, DIMENSIONAL TOLERANCE IS ±1

3 Installation

- Make sure to install the unit in the indoors where the effect of electromagnetic wave or dust can be avoided.
- Keep the minimum amount of space indicated in the below drawing from walls, and between units when installed in series. The minimum depth required for installation is 600mm

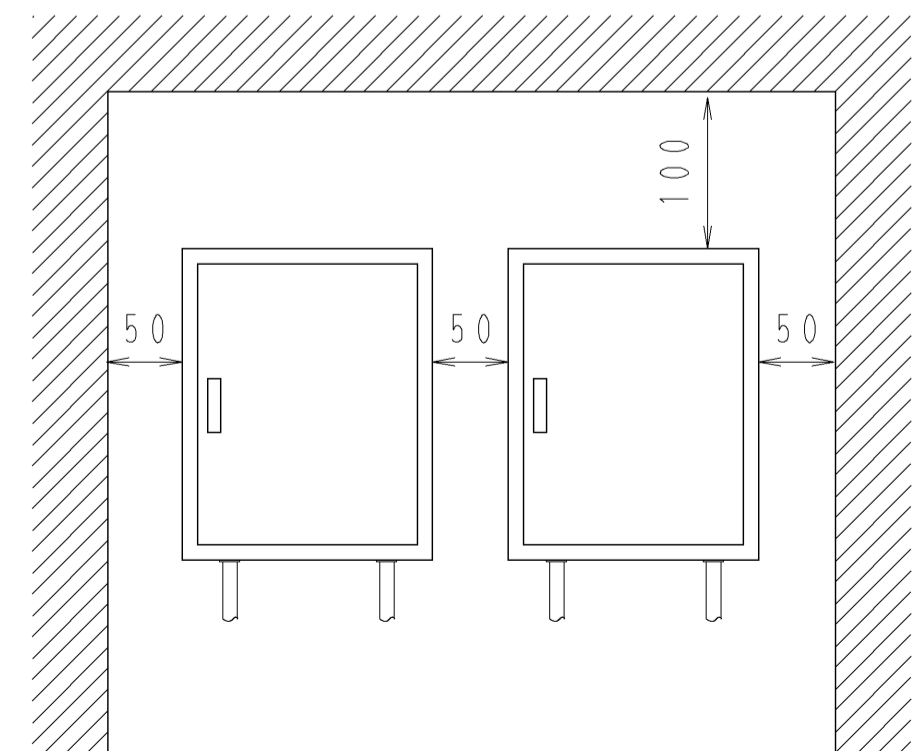
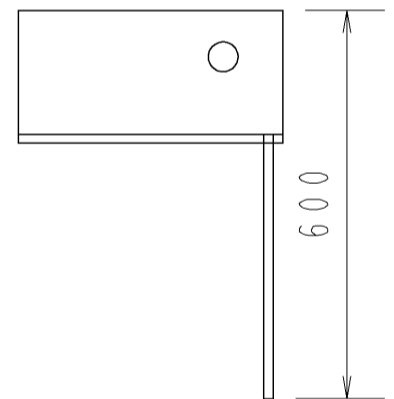

[UNIT: mm]

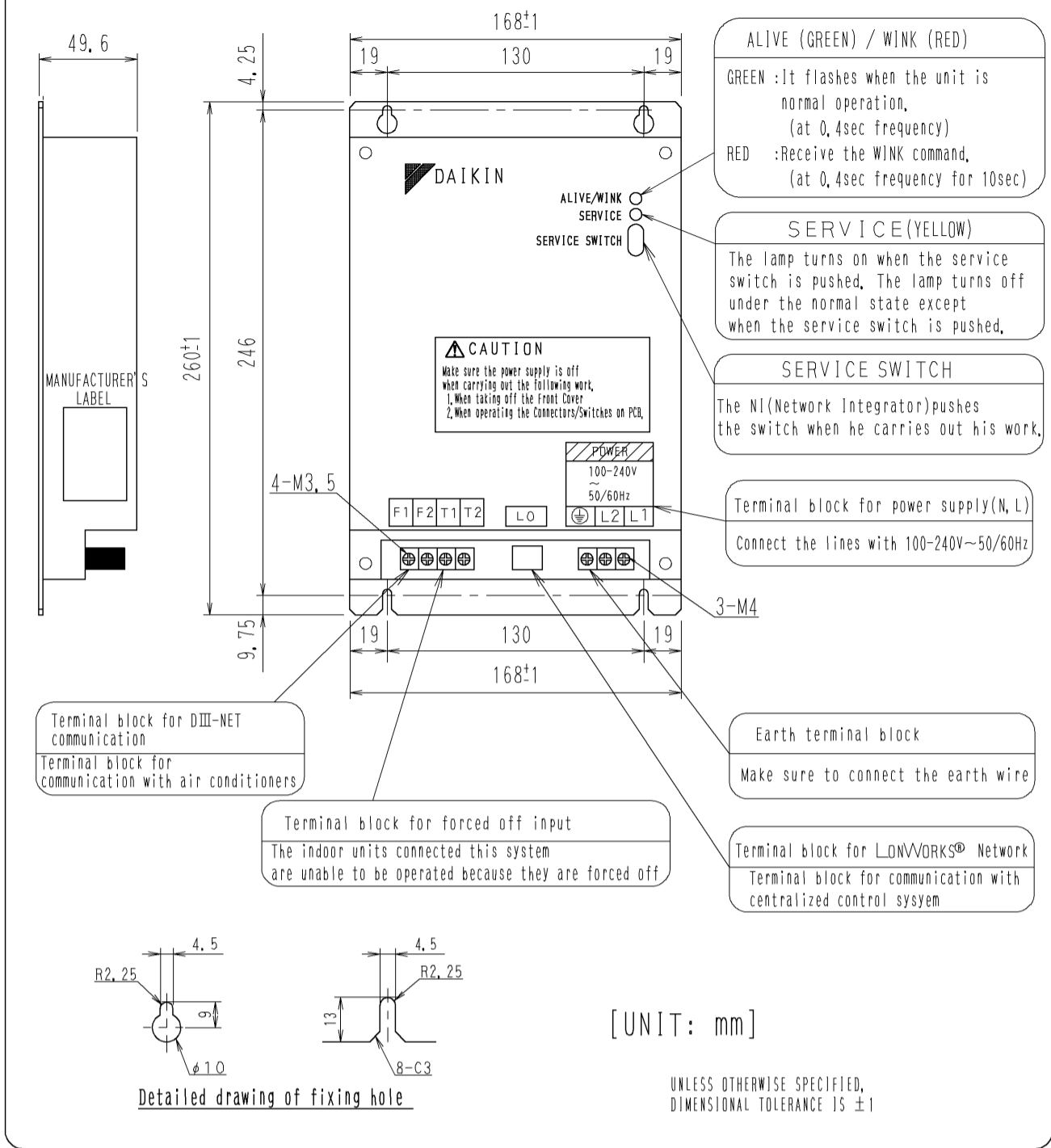

ALIVE (GREEN) / WINK (RED)

GREEN :It flashes when the unit is normal operation, (at 0.4sec frequency)
RED :Receive the WINK command, (at 0.4sec frequency for 10sec)

SERVICE (YELLOW)

The lamp turns on when the service switch is pushed. The lamp turns off under the normal state except when the service switch is pushed.

SERVICE SWITCH

The NI (Network Integrator) pushes the switch when he carries out his work.

Terminal block for power supply (N, L)

Connect the lines with 100-240V~50/60Hz

Earth terminal block

Make sure to connect the earth wire

Terminal block for LANWORKS® Network

Terminal block for communication with centralized control system

[UNIT: mm]

UNLESS OTHERWISE SPECIFIED, DIMENSIONAL TOLERANCE IS ±1

TO BACK